

May 2014

# MARITIME REPORTER AND ENGINEERING NEWS

MARINELINK.COM

# NEIL ARMSTRONG



**Marine Electronics**  
The Father of Modern Navigation Tech

**Offshore Floating Production**  
Shale Oil Boom Pinches Profits Offshore

**Training & Education**  
Sewol Loss: More Questions than Answers

**U.S. Navy's AGOR 27**  
R/V Neil Armstrong Makes a Splash

**Marine Propulsion**  
Emissions & Efficiency Take Center Stage

**Spill Response**  
Interview: Rich Hobbie, WQIS

## SALES • SERVICE • SHOP • ENGINEERING

Factory trained service engineers and technicians on call 24 hours a day, seven days a week - worldwide.

Whether supervising shipyard periods or sailing underway, we offer our customers 100% reliability and satisfaction, that's why our service comes with a one (1) year or 6,000 hour warranty on our field service and component overhauls.

We service most makes and types of diesel engines including medium speed and slow speed engines for the marine industry and stationary power plants. Our modern, fully equipped workshops are staffed by highly trained personnel for the overhaul and recondition of all diesel engine components and fuel equipment.

### Now An Appointed U.S. Agent For Anglo Belgian Corporation

Anglo Belgian Corporation (ABC) is one of Europe's leading medium speed diesel engine manufacturers with over a century of expertise in ship propulsion, locomotive traction, marine and industrial power generating systems.



DZC SERIES



#### West Coast

4200 24th Avenue West, Seattle, WA 98199  
Tel. (206) 282-9142  
24-hr Emergency (206) 518-3181

#### East Coast

5434 West Crenshaw Street, Tampa, FL 33634  
Tel. (813) 830-9180  
24-hr Emergency (206) 940-7326

## POWER AT WORK

Riverine Command Boat (RCB),  
built by SAFE Boats, powered by  
twin Scania 16-liter V8 engines  
Puget Sound, WA



# Complete and Committed.

## THE SCANIA MARINE SOLUTION.

Out there, confidence in performance, reliability and operating economy are the only things that count. With this in mind, we created the Scania marine solution: An array of flexible options including ratings, equipment, instrumentation and transmissions. Whatever your specification, we will provide you with the optimal Scania marine solution.

Power at work, every inch of the way.

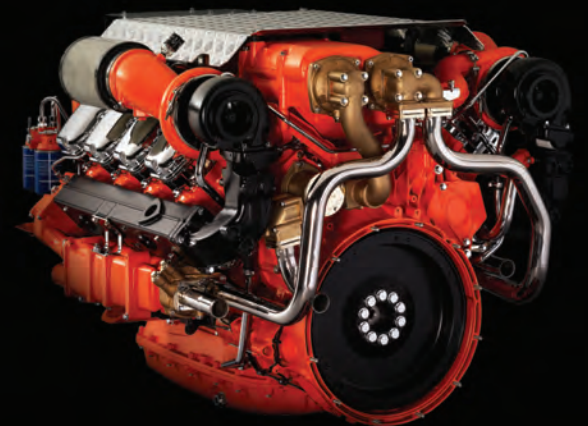

### DISTRIBUTORS

**Northeast/Great Lakes**  
Mack Boring & Parts Co.  
908-964-0700

**Northwest**  
Cascade Engine Center  
206-764-3850

**Southeast**  
Certified Diesel  
954-583-4465

**Southwest**  
Boatswain's Locker  
949-642-6800

**Gulf Coast**  
NREC Power Systems  
504-393-7272

**Central/Eastern Canada**  
ADF Diesel  
800-517-1489

[www.scaniausa.com](http://www.scaniausa.com)



**SCANIA**  
Scania U.S.A. Inc.



22



30



32

(Photo: Hagley Museum and Library)

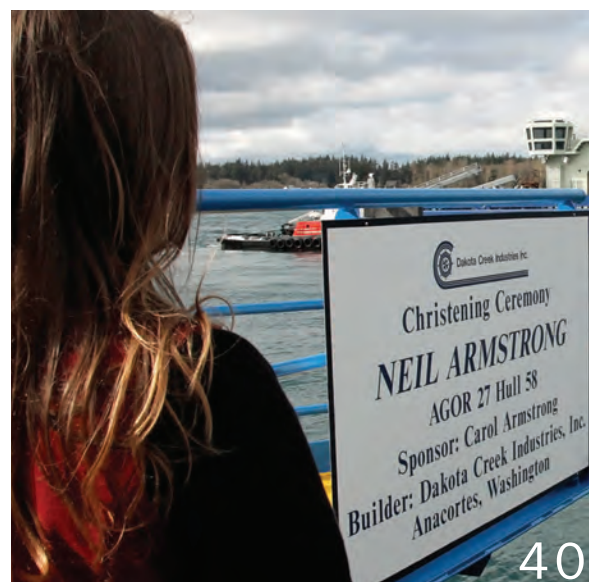

40

(Courtesy of Karla DeCamp, Dakota Creek Industries)



48

IN THIS EDITION

**6 EDITORIAL**

As the Sewol South Korean Ferry story unfolds, the industry collectively faces many tough questions.

By Greg Trauthwein

**22 ERGONOMIC CONTROLS**

Innovations in computer display tech would seem to have hit a plateau, but there is room for improvement.

By Mark Liu

**40 R/V NEIL ARMSTRONG**

AGOR 27 started its official life as the R/V Neil Armstrong, the first research vessel named after a space explorer.

By Kathleen Gleaves

**16 TREATMENT OF FOREIGN SEAFARERS**

The United States effectively treats foreign seafarers more harshly than any other group that enters the country.

By Dennis L. Bryant

**30 DOES E-LEARNING WORK**

According to the author, it's time to put that question behind us and integrate e-Learning into the training & education mix.

By Murray Goldberg

**44 MARINE PROPULSION**

As new tech for the marine sector evolves rapidly, MR sought thoughts from Class on the burning propulsion issues of the day.

By Greg Trauthwein

**20 SEEMP**

SEEMP can make fleets more competitive while reducing impact on the natural environment.

By Jose Femenia, P.E.

**32 ELMER A. SPERRY**

Profile of a historic inventor and innovator, widely regarded as the Father of Modern Navigational Technology.

By Patricia Keefe

**28 INTERVIEW: RICH HOBBIE, WQIS**

WQIS is the largest underwriter of pollution liability insurance in the U.S., and Rich Hobbie discusses the challenges today.

By Greg Trauthwein

\*Based upon field testing of Mobil Delvac 1™ ESP 5W-40 in high-speed, 4-stroke marine engines, and compared with conventional heavy-duty diesel engine oil. Actual results may vary by engine type, maintenance, operating conditions, environment and prior lubricant use. Drain intervals should be established through routine used oil analysis.  
© 2014 Exxon Mobil Corporation. The Mobil logo and Mobil Delvac 1 and any other trademarks are trademarks of Exxon Mobil Corporation, or one of its subsidiaries.

# From grain to coal, together we tow it all

You keep entire economies moving. Mobil Delvac 1™ ESP fully synthetic diesel engine oil can help you operate more safely and effectively. **It delivers up to ten times the drain intervals\***, which means less vessel downtime and more efficient operations. To learn more, visit [exxonmobil.com/mobildelvacmarine](http://exxonmobil.com/mobildelvacmarine).

**Mobil Delvac 1™**

**8 STRAIGHT TALK; WINDING RIVERS**

Last month's IRPT meeting in St. Louis highlighted the tremendous value and future needs of the inland waterway system.

By Joseph Keefe

**12 OFFSHORE FLOATING PRODUCTION**

The Offshore Floating Production sector has hit some stiff headwinds, powered by the shale oil and gas revolution in the U.S.

By Jim McCaul

**19 HYDRODYNAMIC SOFTWARE SUITES**

To support designers and engineers in evaluating design concepts more efficiently, MARIN has developed the hydrodynamic suites QSHIP and QPROP.

By Arno Bons

**24 LITIGATE OR ARBITRATE: THAT IS THE QUESTION**

When it comes to dispute resolution clauses, there is no one-size-fits-all solution, and the decision whether to arbitrate or litigate may be more complex than anticipated.

By Alan M. Freeman

**26 SEWOL: TRAGEDY STRIKES AGAIN**

Though early in the investigation, the tragic story of Sewol again centers on actions of the captain and crew.

By Greg Trauthwein

**50 PEOPLE & COMPANY NEWS**

**52 PRODUCTS: DECK MACHINERY**

**55 PRODUCT FEATURE: MARINE ELECTRONICS**

**59 BUYER'S GUIDE**

**60 CLASSIFIEDS**

**64 ADVERTISER'S INDEX**



Photo: Alex Sergienko

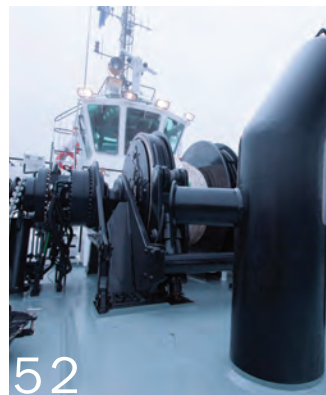

Source: Damen Shipyards Group



**FROM OUR ARCHIVES**



© new wave media

**THE COVER**



**Pictured on this month's cover** is Carol Armstrong cracking the champagne bottle to officially christen the R/V Neil Armstrong, named to honor her late husband and world-famous astronaut Neil Armstrong.

Full details on the R/V Neil Armstrong starts on page 40.

(Courtesy of Karla DeCamp, Dakota Creek Industries)

**MARITIME REPORTER AND ENGINEERING NEWS**  
 www.marinelink.com

**NEW YORK**  
 118 E. 25th St., New York, NY 10010  
 Tel: (212) 477-6700 • Fax: (212) 254-6271  
 e-mail: mren@marinelink.com  
 Web: www.marinelink.com

**FLORIDA**  
 215 NW 3rd St., Boynton Beach, FL 33435  
 Tel: (561) 732-4368; Fax: (561) 732-6984

**PUBLISHERS**  
**John E. O'Malley**  
 John C. O'Malley jomalley@marinelink.com

**Associate Publisher & Editor**  
**Gregory R Trauthwein** trauthwein@marinelink.com

**EDITORIAL**  
**Web Editor** Eric Haun haun@marinelink.com  
**Contributing Editors** Dennis L. Bryant, Joseph Keefe, Ned Lundquist  
**Correspondents** Joseph Fonseca, India, Greg Knowler, China  
 Claudia Pashoa, Brazil, Peter Pospiech, Germany

**Editorial Consultant** **James R. McCaul**  
 President, International Maritime Assoc.

**PRODUCTION**  
**Production Manager** Irina Tabakina tabakina@marinelink.com

**CORPORATE STAFF**  
**Manager, Accounting** Esther Rothenberger rothenberger@marinelink.com  
**Manager, Public Relations** Mark O'Malley momalley@marinelink.com  
**Manager, Information Technology Services** Vladimir Bibik bibik@marinelink.com

**CIRCULATION**  
**Circulation Manager** Kathleen Hickey mrcirc@marinelink.com

**SALES**  
**Vice President of Sales & Marketing**  
 Rob Howard howard@marinelink.com

**National Sales Manager**  
 Terry Breese breese@marinelink.com t: (561) 732-1185 f: (561) 732-8414

**Sales Representatives**  
**Lucia Annunziata** annunziata@marinelink.com t: (212) 477-6700 f: (212) 254-6271  
**Frank Covella** covella@marinelink.com t: (561) 732-1659 f: (561) 732-8063  
**Mitch Engel** engel@marinelink.com t: (561) 732-0312 f: (561) 732-8063  
**Mike Kozlowski** kozlowski@marinelink.com t: (561) 733-2477 f: (561) 732-9670  
**Dawn Trauthwein** dtrauthwein@marinelink.com t: (631) 472-2715 f: (631) 868-3575  
**Jean Vertucci** vertucci@marinelink.com t: (212) 477-6700 f: (212) 254-6271

**Sales & Event Coordinator** **Michelle Howard**  
 mhoward@marinelink.com

**INTERNATIONAL SALES REPRESENTATIVES**

**Scandinavia** Roland Persson roland@orn.nu  
 Orn Marketing AB, Box 184, S-271 24 Ystad, Sweden  
 t: +46 411-184 00 f: +46 411 105 31

**Western Europe** Uwe Riemeyer riemeyer@intermediapartners.de  
 t: +49 202 27169 0 f: +49 202 27169 20

**United Kingdom** Paul Barrett ieaco@aol.com  
 Hallmark House, 25 Downham Road, Ramsden Heath,  
 Essex CM11 1PU UK t: +44 1268 711560  
 m: +44 7778 357722 f: +44 1268 711567

**Japan** Katsuhiko Ishii amskatsu@dream.com  
 Ace Media Service Inc., 12-6, 4-chome, Nishiike, Adachi-ku, Tokyo 121, Japan  
 t: +81 3 5691 3335 f: +81 3 5691 3336

**Korea** Jo, Young Sang biscim.co.kr  
 Business Communications Inc., Rm 1232, Gwanghwamoon Officia Bldg., 163,  
 1-Ga, Shinmoon-Ro, Jongro-Gu, Seoul, Korea 110-999  
 t: +82 2 739 7840 f: +82 2 732 3662

**Classified Sales** t: (212) 477-6700

Member

# MAN Alpha

## Controllable pitch propellers



Diesel-Mechanical Systems Diesel-Electric Systems Propellers Gearboxes Propulsion Management Systems

MAN Diesel & Turbo's Alpha propeller programme has been extended with two new larger hub sizes (VBS 2060 and VBS 2150) – offering power transmission of up to and beyond 40,000 kW. Today's high-efficient CP Propellers are created on the basis of state-of-the-art design tools and the accumulated experience from more than 7,000 units. Full pitch ahead!

Find out more at [www.mandieselturbo.com](http://www.mandieselturbo.com) and [www.manalpha.com](http://www.manalpha.com)

Engineering the Future – since 1758.

**MAN Diesel & Turbo**



# Sewol ... Many Question, Few Answers



GREG TRAUTHWEIN, EDITOR & ASSOCIATE PUBLISHER

**W**ith today's 24/7/365 news cycle, anyone with an internet connection and a device can log-in and receive news from virtually anywhere around the world as it happens. This comes with advantages and disadvantages, as today the world seems a much smaller, much more 'informed' place, but at the same time it is important to remember that erroneous information flows as freely and fast as correct information.

As an example, today the grim details of the sinking and tremendous loss of life aboard the South Korean ferry are well-known, and the name "Sewol" will live in infamy in the maritime history books. At press time the recovery of dead continues, despite initial news reports from the scene that proclaimed "All South Korean Students and Teachers Rescued."

While there have been far bigger wrecks with many more dead, this one struck a nerve in that of the 476 passengers and crew onboard, 339 were children and teachers on a high school outing for what was planned as a routine sailing from the Port of Incheon to the southern island of Jeju. It will take

months if not years before the final chapter on Sewol is written, and perhaps the tale will never fully be told. But in the immediate aftermath, more than 300 remain missing and are presumed dead, a disgraced South Korean Prime Minister has resigned, Captain Lee Joon-seok and many of his crew are in jail, and there are more questions than answers.

There are many disturbing facts about this case, starting first and foremost with the number and age profile of the souls lost; the actions of the captain and certain crew which suggests their actions contributed mightily to the loss of life; the accusations from the president of Korea that essentially accused the captain of "murder" ... the list goes on.

With early focus and outrage set squarely on the captain and crew, we focus here on the role of the maritime training and education community in helping to mitigate the risk of future maritime casualties.

While the investigation is still fresh and we certainly have drawn no conclusions, we reached out to several maritime training and education experts for their insights.

You can read the full story starting on page 26, but as we report here, and have done some many times before: training and education is only as valuable as the mariner chooses to employ skills learned onboard a ship; technology is helpful, but not the sole answer; and situational awareness of ship, crew and surroundings is key ... distilled perfectly by **Jeff Cowan** as he simply advises: "Look out the window."

This month is also a continuation of *Maritime Reporter's* 75th Anniversary, and I'm happy to say that **Patricia Keefe** has delivered once again with an insightful profile of **Elmer A. Sperry**, inventor and innovator, widely regarded as the Father of Modern Navigational Technology. Read her report starting on page 32 and see if you agree that Sperry deserves this lofty title.

trauthwein@marinelink.com

|   |  |  |
|---|--|--|
| ISSN-0025-3448<br>USPS-016-750<br>No. 5 Vol. 76 | 118 East 25th Street, New York, NY 10010<br>tel: (212) 477-6700; fax: (212) 254-6271 | Founder: John J. O'Malley 1905 - 1980<br>Charles P. O'Malley 1928 - 2000 |
|---|--|--|

Maritime Reporter/Engineering News (ISSN # 0025-3448) is published monthly by Maritime Activity Reports, Inc. 118 East 25th Street, New York, NY 10010. Mailed at Periodicals Postage Rates at New York, NY 10199 and additional mailing offices. Postmaster send notification (Form 3579) regarding undeliverable magazines to Maritime Reporter & Engineering News, 850 Montauk Hwy., #867, Bayport, NY 11705. Publishers are not responsible for the safekeeping or return of editorial material. © 2014 Maritime Activity Reports, Inc. All rights reserved. No part of this publication may be reproduced or transmitted in any form or by any means mechanical, photocopying, recording or otherwise without the prior written permission of the publishers.

|  |  |  |                                      |   |
|--|--|--|--------------------------------------|---|
|  |  |  | Download our App<br>iPhone & Android | Check out our Websites:<br><a href="http://www.marinelink.com">www.marinelink.com</a> / <a href="http://www.maritimeprofessional.com">www.maritimeprofessional.com</a> / <a href="http://www.maritimepropulsion.com">www.maritimepropulsion.com</a><br><a href="http://www.maritimejobs.com">www.maritimejobs.com</a> / <a href="http://www.marinetechologynews.com">www.marinetechologynews.com</a> / <a href="http://www.maritimeequipment.com">www.maritimeequipment.com</a><br><a href="http://www.marineelectronics.com">www.marineelectronics.com</a> / <a href="http://www.yachtingjournal.com">www.yachtingjournal.com</a> / <a href="http://www.maritimetoday.com">www.maritimetoday.com</a> |
|--|--|--|--------------------------------------|---|

|   |   |
|---|---|
| <p><b>SUBSCRIPTION INFORMATION</b></p> Subscription Information<br>• in U.S.: One full year (12 issues) \$84.00; two years (24 issues) \$125.00<br>• Rest of the World: One full year (12 issues) \$110.00; two years \$190.00 including postage and handling.<br>Email: mrcirc@marinelink.com • www.marinelink.com t: (212) 477-6700 • f: (212) 254-6271 | <p><b>POSTMASTER:</b> Send address changes to: Maritime Reporter &amp; Engineering News, 850 Montauk Hwy., #867, Bayport, NY 11705. Maritime Reporter is published monthly by Maritime Activity Reports Inc. Periodicals Postage paid at New York, NY and additional mailing offices.</p> |
|---|---|





# FURUNO ECDIS

Electronic Chart Display  
and Information System

## Finally, an ECDIS designed for navigators by navigators!

- 100% Furuno designed Linux software improves stability & reduces virus risk
- Fully compliant IMO systems (19" & 23.1" LCD) or Black Box ECDIS with user supplied wide glass bridge monitors are available
- Simple Ethernet connection to FAR2xx7 Radars, saving thousands over complex interface kits
- Fast redraw & intuitive route creation
- Easy auto-load function greatly simplifies chart loading & updating
- USB Jump Drive on keyboard supports easy data import & export
- 10 custom user profiles allow quick recall of user preferences
- Screen capture function stores up to 100 ECDIS/Radar images
- Customizable conning screens are provided as standard supply
- Extra DVI-I output port for convenient connection to Voyage Data Recorder



**FMD3200/3300 ECDIS**



**FAR2xx7 RADAR**



**Four customizable conning displays are available as standard supply**

**EXCLUSIVE: World's first IMO ECDIS that directly interfaces with Furuno's FAR2xx7 Radar Series!**



For more information on the New Furuno ECDIS, scan QR Code.

**FURUNO**  
www.FurunoUSA.com

# GO DIGITAL

When you leave the page and head to the screen, Maritime Reporter's family of online offerings provides the most digital and online news portals for news & insight. For news and insight, visit [MaritimeProfessional.com](http://MaritimeProfessional.com)

Get the Maritime Professional App for iPhone, Android and Windows devices



By Joseph Keefe

## Straight Talk; Winding Rivers

**“The only holdup to more oil on the river is the strength of the rail and trucking lobbies.”**

Dennis Wilmsmeyer, outgoing IRPT President

According to St. Louis Mayor **Francis Slay**, more than one million tons of cargo passes the iconic St. Louis arch annually on its way to various inland and foreign destinations. In fact, it ranks as the second busiest inland port in America. In part because of that, he said at this year's Annual Meeting of the Inland Rivers, Ports & Terminals Association, “We need to protect the river(s) as national and regional assets.” And with that, he set the tone for the three day event which kicked off late last month in St. Louis. But, he added, commerce was only one part of the equation. Slay then listed the environment, economic, flood control and recreational stakeholders who also depend on not just the Missouri and Mississippi Rivers [which come together here], but all inland rivers, locks, dams and other similar infrastructure.

With many regional river city mayors in attendance, Slay recognized the important role of the marine industry in the local economy while also lamenting the annual \$200 billion cost to the national economy because of freight bottlenecks – most of which occur in other modal areas such as rail and trucking. Beyond this, he also pointed out the ongoing federal indifference to perhaps the most important aspect of the American economy. According to Slay, China today invests as much as 9% of its GNP on infrastructure improvements, as compared to just 3% on the American side of the equation. Those sorts of numbers, of course, aren't confined to U.S.-China comparisons. South American countries, for example, looking proactively at an expanded Panama Canal, are quickly ramping up their own inland resources and rivers. This leaves me to wonder who will be getting their raw resources and grain to market quicker, more efficiently and cheaper in

the coming years. Talks in St. Louis also touched upon a regional effort by stakeholders to revive a dormant but promised “container on barge” service on the rivers. An initial stab at this concept, something that began before the recent financial crisis, fell victim to declining freight volumes during the recession. Looking (perhaps) to the success of similar efforts on the James River in Virginia, where tens of thousands of trucks have been removed from the I-64 corridor, the IRPT and other local business interests are trying to stimulate its revival. Regional port mayors in attendance signed a “Container on Barge” resolution as testimony of their support. A flicker of life in the nation's hopes for a robust marine highway/shortsea shipping movement. Also speaking at the opening luncheon was outgoing IRPT President **Dennis Wilmsmeyer**, newly elected IRPT President **Hugh McConnell** and **Otis Williams**, Executive director of the St. Louis Development Corporation. Wilmsmeyer told us that IRPT remains dedicated to promoting the fight for the inland rivers, wherever and whenever possible. Asked about the likelihood of increased petroleum cargoes entering the rivers from the ongoing energy boom to the north, he insisted, “The only holdup to more oil on the river is the strength of the rail and trucking lobbies.”

### WRRDA

Port authority and terminal representatives received a tutorial on the status of WRRDA or Water Resources Reform and Development Act of 2013, which currently languishes in committee in our nation's Capitol. Industry stakeholders hope for a resolution between the House and Senate versions soon, so that the important business of recapitalizing our

nation's inland waterway infrastructure can continue, but also be done in a more expeditious and efficient manner. If there was one take-away from the collective thoughts of **Robert Shuster** (Buchanan, Ingersoll and Rooney, P.C.), **James Kearns** (Partner with Bryan Bryan, Cave, LLP) and **Paul Rohde** (Vice President of Waterways Council, Inc.), it could be said that describing the ongoing process in Washington is complicated. And, that public-private partnerships will likely be part of the solution in the years to come.

### Sea Change

Wednesday's Keynote was given by Acting U.S. Maritime Administrator **Paul “Chip” Jaenichen**, whose public profile has, in the past couple of months, increased exponentially as he crisscrosses the country advocating for the domestic waterfront. The charismatic Jaenichen is a refreshing sea change for MarAd and his energy and obvious enthusiasm for the job has given the maritime community – no matter what sector they emanate – some small glimmer of hope that the maritime part of the modal equation will soon take its rightful place in the national intermodal picture. That said; the MarAd chief made it clear that we still have a long way to go.

Jaenichen told conference attendees that by 2050, the U.S. will need to move another 14 billion tons of freight; 10 billion of that domestically. Inevitably, he said that will lead to more congestion, but at the same time said, “It doesn't have to be that way.” Not if we can develop and maintain our “under-utilized” inland waterways, he added. The acting administrator went on to describe a rapidly burgeoning “designated marine highway” in California, where another ‘container on barge’ service is currently

removing as many as 200 trucks weekly from California's choked highway system. Jaenichen talked about many things, but for his part, pledged to “bring maritime into the conversation and ensure that marine transport becomes part of the intermodal equation.” He also insisted that the **Obama Administration** is already putting the maritime mode on what he characterized as “equal footing” with the other modes. And, while the real federal transport spend numbers don't necessarily back that up, the rhetoric was well received by this mostly C-suite inland river audience. He also introduced some new concepts and programs – one a partnership with AAPA – designed to make it easier for stakeholders to communicate and get things done. These included such acronyms as “Strong Ports,” “Port Talk” and something he has coined as maritime “tool kits.” It all sounds good; assuming any of it gathers momentum.

### Straight Talk, Winding Rivers

Growing organizations like IRPT and a Maritime Administration that has retooled itself (after nearly five years of benign neglect under Ray LaHood's tenure as Transportation Secretary) will all be needed as we collectively try to solve 50 years of the same neglect of our inland infrastructure and waterways. A robust group of stakeholders came together in St. Louis to sow the seeds for what will come next.

The shortest distance between any two points – in this case, a fully functioning inland waterway system – is typically a straight line. And yet, we can't seem to get there. The answers are, apparently, as long and winding as the river issue(s) they hope to help. This week was a step in the right direction.

ENVIRONMENTAL SAFETY FACT:

**70,000+**  
**MARINE SAFETY INSPECTIONS**  
**ARE CONDUCTED ON DOMESTIC VESSELS**

**EACH &  
EVERY  
YEAR**



**ENVIRONMENTAL SAFETY SOLUTIONS.**

The U.S. Coast Guard is charged with protecting the marine environment. That includes enforcing the revised 2013 Vessel General Permit. Clarion<sup>®</sup> Lubricants is committed to helping you comply with these regulations. Our readily biodegradable products are classified as Environmentally Acceptable Lubricants and provide confident protection for your operation. And our waters.

For lubricant solutions that will keep your marine operation in compliance, visit [ClarionEnviroSafety.com](http://ClarionEnviroSafety.com).



## FUEL SAVER

**BOS Provides 2-5% Fuel Savings**

With consistent results of 2-5% fuel savings, Keppel Offshore & Marine's subsidiary Blue Ocean Solutions (BOS) said that it has proved that emulsified fuel can bring significant fuel savings adding to the well established NOx reduction, if done correctly. The patented BOS Emulsified Fuel System (EFS) is designed to improve combustion efficiency by improving the injector fuel atomization. In addition to the measured fuel savings, firm evidence of better combustion has also been recorded in the form of increased heat release rate.

The key success factor in emulsified fuel is the ability to produce and maintain the optimum 10% water as water-in-fuel particle sizes of 2-8 microns. This is

achieved with the patented BOS Emulsifier that has no moving, cavitating or vibrating parts. The system has been tested on both two-stroke and four-stroke engines. Diamond Shipping, one of the largest owner and operator of product tankers in

the world, was the most recent to place an order for BOS EFS to improve fuel efficiency. To date, references include American President Line APL, Regent Seven Seas Cruises, Wärtsilä, Townsend Thoresen, London Overseas Freighters, B&I and others. Even with numerous references under its belt, Blue Ocean Solutions has been cautious in rolling out information to the industry, instead waiting for independent verifications by class societies, engine manufacturers and ship owners. Wärtsilä has also tested the system under the Project Hercules on medium speed engine Wärtsilä 6L20CR operating under Miller cycle with a two-stage turbocharger and running on MGO. The tests confirmed improved fuel efficiency with no need for chemical additives.

Blue Ocean Solutions introduced the BOS EFS in 2010 in response to the sudden steep hike in fuel oil prices. Yet, the R&D work goes back to the early 1980's. Dr Jerry Ng KL, the founder and CEO of Blue Ocean Solutions was one of the members of the team that pioneered the application of emulsified fuel technology to motor ships at the University of Newcastle, U.K.

<http://blueoceansoln.com/>



## NEW CONCEPT

# Eliminating Crude Oil Spill Spread

**A** new method is available which purports to stop the spread of major oil spills in offshore areas. It involves a floating ring-like device called Protection Ring Offshore Environment (PROE) that encircles the drilling rig. It has a curtain suspended vertically from the ring bottom that is designed to retain the oil spill. PROE is self-propelled and is submersible, meaning it is able to 'chase' oil spills if necessary. When not in use it can be submerged 50-ft. below marine surface traffic. It may also be divided into several parts in case the spill accumulates in several areas. PROE was developed following the BP Macondo oil spill in the Gulf of Mexico.

The American Energy Investment Group, a Houston independent oil company, reports it is implementing PROE, the oil spill retainer system shown in **Figure 1**. American Energy is the developer and owner of the PROE patent, which was issued in 7.5 months.

PROE is assigned continuously to the rig during all drilling and completion operations. In the event of a blowout or other accident PROE is surfaced, the two ends are locked together to encircle the rig and the retainer curtain is deployed

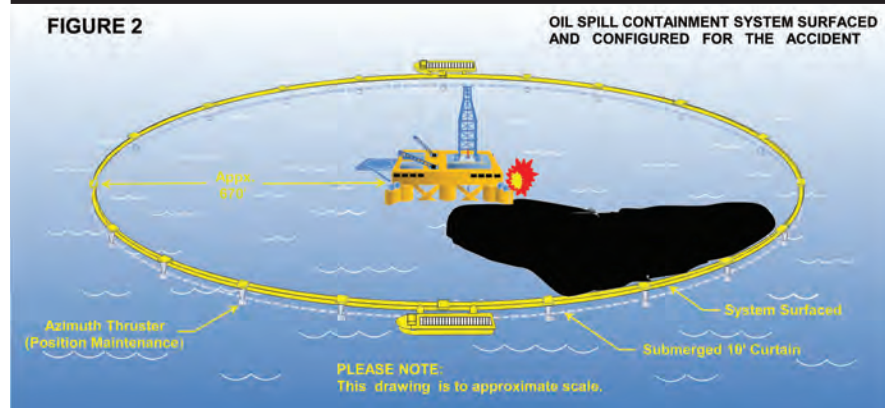
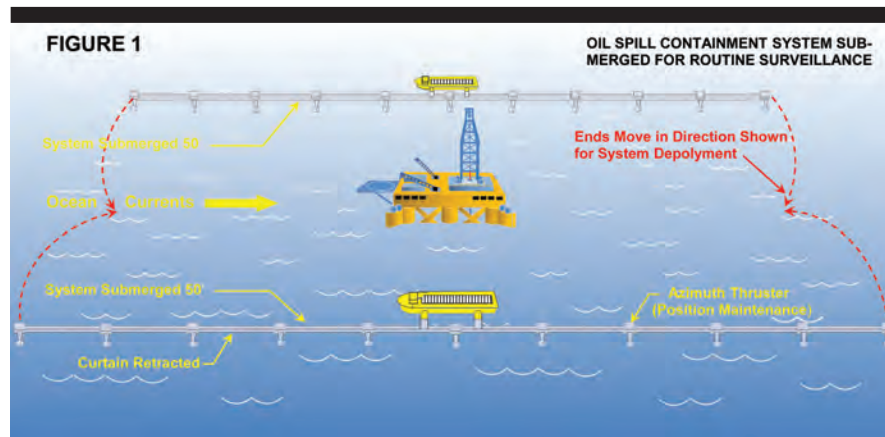

as shown in **Figure 2**. Set-up operations are estimated to require less than one hour. The azimuth thrusters provide the force necessary to move PROE into the correct position and maintain that loca-

tion with the aid of GPS. Depending upon the circumference of the system and curtain height, PROE developers claim that it can contain in the order of about 2.5 to over 5.0 million barrels.

## Ingalls Delivers Navy Power



Photo: Lance Davis, Huntington Ingalls Industries

**George Jones (left), Ingalls Shipbuilding's LHA 6 program director, welcomes Capt. Robert Hall Jr. aboard the amphibious assault ship America (LHA 6) to sign the DD 250 document officially transferring custody of the ship to the U.S. Navy.**

**H**untington Ingalls Industries' (HII) Ingalls Shipbuilding division delivered the amphibious assault ship America (LHA 6) to the U.S. Navy. When America enters the fleet, she will be the flagship of an Expeditionary Strike Group, strategically positioning Marine Expeditionary Units ashore. America-class ships are 844 ft. long and 106 ft. wide and displace 44,971 long tons. The GE gas-turbine propulsion system will drive the ships in excess of 20 knots. It will accommodate a crew of 1,059 (65 officers) and 1,687 troops. The America class will be capable of carrying a Marine Expeditionary Unit, including Marine helicopters, MV22 Osprey tiltrotor aircraft and F35B Joint Strike Fighter aircraft.

The newest class has an increased aviation capacity to include an enlarged hangar deck, realignment and expansion of the aviation maintenance facilities, a significant increase in available stowage for parts and support equipment, and increased aviation fuel capacity.



See the crane barge in action.  
Scan this ad with your Layar-app.



## DAMEN CRANE BARGE 6324

### NEW DESIGN – TRANSSHIPMENT BARGE – AVAILABLE FROM STOCK

Our newly designed 63 m Crane Barge basically serves 3 purposes: ship-to-ship, ship-to-barge and ship-to-quay dry bulk or container handling. Because we believe in this concept, we have already built a number of them, allowing for a very short delivery time.

Why?

- Fuel efficient Liebherr CBG 350 crane
- Shallow draught and high stability
- Day / night accommodation for 12 crew
- Turnover up to 1.000 ton per hour
- Grab capacity of 35 ton @ 36 m



# DAMEN

# Floating Production System Orders *Outlook*



BY JIM MCCAUL, IMA

An EPC contract for a production unit can easily exceed \$1 billion – and \$3 billion for an FPSO has recently been breached. Overall, this is a \$20 to \$30 billion annual market. But, as described below, the sector is hitting some headwinds that could impact future business opportunities.

## Backlog of Planned Floater Projects

243 floating production projects are in various stages of planning as of beginning May. Of these, 57% involve an FPSO, 16% another type oil/gas production floater, 23% liquefaction or regasification floater and 5% storage/offloading floater.

Brazil, Africa and SE Asia are the major locations of floating production projects in the visible planning stage. We are tracking 50 projects in Brazil, 49 in Africa and 46 projects in SEA – 60% of the visible planned floating production projects worldwide.

Around 25% of the projects are at an advanced stage of development. They typically have either entered the FEED phase, pre-qualification of floater contractors has been initiated or bidding/negotiation is in progress. Award of the production floater contract in these projects is likely within the next 2-3 years. The remaining 75% of the planned projects are in an early stage of development. Contract awards are

more likely in the 3+ year time frame.

## Future Business Drivers

The large number of projects at the ready-to-go stage is clearly a positive indicator for future floating production equipment orders. However, timing of the decision to proceed to contracting will be influenced by future underlying market conditions. Fundamentals driving future orders in the floating production market remain generally positive. World oil and gas demand continues to grow, crude pricing remains in the \$100 to \$110 range and deepwater drillers are operating at high utilization. But the sector is hitting competition from shale/tight oil and gas supply, energy companies have been cutting capital spending budgets and deepwater drillers are not quite as bullish as in recent past.

## Growing Demand for Oil and Gas

On the positive side, global oil demand has grown at an average rate of 1.4% annually over the past 20 years. With the exception of two years during the global financial meltdown, oil demand has increased year over year during this period. Growth in oil demand is widely expected to continue over the foreseeable future. The IEA, for example, sees world oil demand in 2035 growing to 101 mb/d, an increase of 11% over today. Global natural gas demand is also growing. Gas consump-

tion doubled between 1980 and 2010 and has grown another 13% since. Over the past decade global natural gas consumption declined in only one year – 2009 as a result of the financial crisis.

The EIA sees world gas consumption growing at an annual rate of 1.7% through 2040. ExxonMobil projects a 65% increase in natural gas demand by between 2010 and 2040.

## Unconventional Oil & Gas Supply

But unconventional oil and gas resources are changing the supply landscape. Use of horizontal drilling and hydraulic fracturing to exploit oil and gas resources locked in shale, siltstone and mudstone, as well as production of oil from oil sands, has opened huge new sources of energy supply.

Nowhere is the development of unconventional oil resources more rapidly advancing than in North America. Between 2011/2014 the production of oil in the US and Canada increased 39%, primarily the result of incremental production of shale/tight oil in the US and oil sands resources in Canada. As a result, production of oil in the US and Canada now accounts for 27.6% of non-OPEC oil production – up from 22% in 2011.

Development of shale/tight oil resources outside the US has been much slower due to land rights issues, access to drill equipment, environmental op-

position to fracking, etc. But the shale/tight oil revolution will undoubtedly spread beyond the US. Opportunities are too big to ignore. The EIA estimates that shale/tight oil resources worldwide total 345 billion barrels – and account for 10 percent of global oil reserves.

The equally spectacular revolution in shale/tight gas production is changing global gas supply and is threatening the dominance of major players in the LNG sector. And like shale/tight oil, the shale/tight gas revolution is centered in North America.

Production of shale/tight gas in the US is projected to grow 52% over the next decade. According to the EIA, shale and tight gas is expected to provide 71% of US natural gas production in 2024, up from 61% today. In 2024 the US is expected to be producing 22.5 TCF of natural gas from shale and tight rock formations – the equivalent of more than three times the current natural gas production of Qatar.

A substantial, though yet unclear, portion of future U.S. gas production will be exported as LNG. BP expects that the U.S. “will become a net LNG exporter from 2016, reaching a total net LNG export volume of 11.2 Bcf/d by 2035.” ExxonMobil sees North America shifting “from a net importer to a net exporter of natural gas by 2020 as production outpaces demand.”

Like oil, development of shale/tight

## Planned Projects Type of Production System Required

(As of May 1, 2014)

| Type of Required | No. of Projects |
|------------------|-----------------|
| FPSO             | 138             |
| Other FPS        | 38              |
| FLNG             | 31              |
| FSRU             | 24              |
| FSO              | 12              |
| <b>Total</b>     | <b>2243</b>     |

## Annual Growth in Global Oil Demand Over Past Two Decades

(% change year over year)

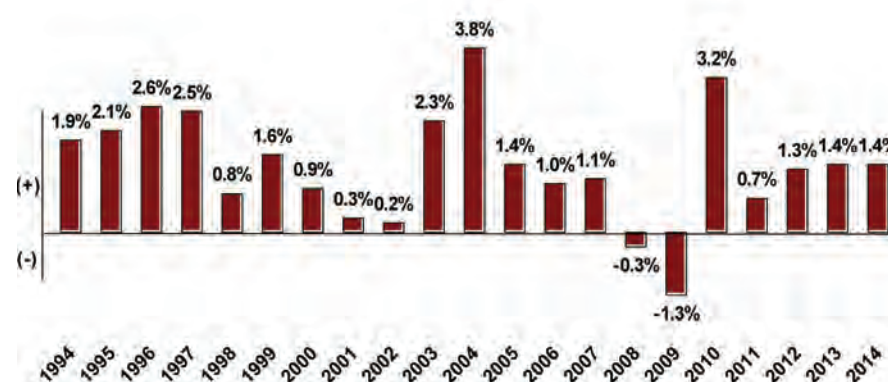

Source: IEA

## Projected Growth Global Natural Gas Demand

(Quadrillion Btu)

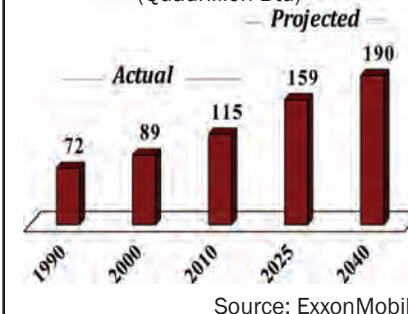

Source: ExxonMobil

gas resources outside the US has been much slower due to land rights issues, limited drill equipment, environmental opposition to fracking, etc. But the shale/tight gas revolution will undoubtedly spread beyond the US. As with shale/tight oil, the opportunities are too big to ignore. The EIA estimates that world shale gas resources total 7299 Tcf – 32% of world natural gas resources

Shale/tight oil and gas development ultimately competes with deepwater for investment resources. These resources are finite – and energy companies will channel their investment resources to the opportunities offering the best financial return. Given the advances taking place in the shale/tight rock sector, it is reasonable to conclude that the shale/tight rock revolution is eroding investment in deepwater projects.

Significantly, the competitive balance is shifting in favor of shale/tight rock. The cost of drilling shale/tight wells is falling – and well productivity is increasing. Meanwhile, technical challenges of ultra-deepwater development, local content barriers and an overheated industrial base are forcing deepwater costs higher.

The pace of activity in the deepwater drilling sector is one of the best predic-

## Projected U.S. Natural Gas Production From Shale and Tight Rock Formations

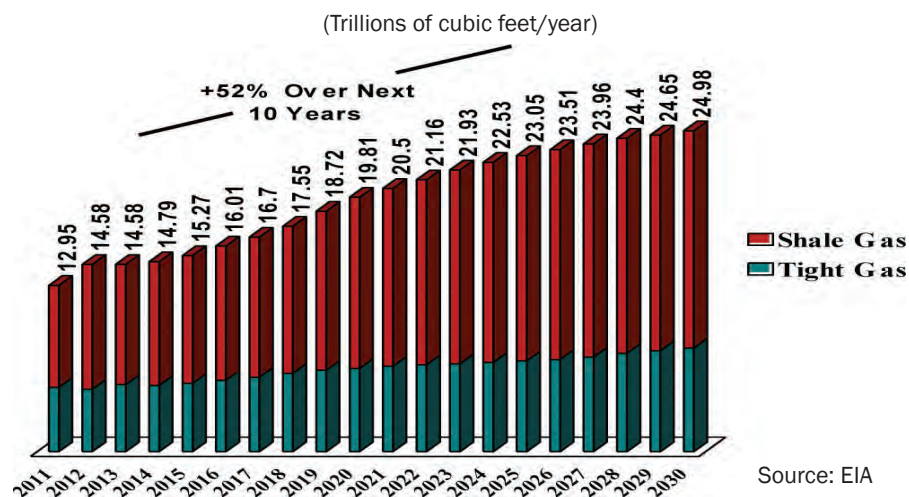

tors of future equipment demand in the floating production sector. The higher the pace of activity in the drill sector, the better the outlook for future floating production project starts. According to Rigzone, drillship utilization in April was 84.8%, semisubmersible rigs 85.7%. This includes utilization of drillships/semis in the competitive inventory. These figures are historically strong and there has been little change in utilization over the past year. But the less-than-positive message that many

drillers recently have been giving about anticipated market conditions in deepwater drilling suggests a softening in the drill market is taking place – which is not good news for near term deepwater projects starts.

Global oil demand keeps growing, but growth in unconventional oil supply is pressuring future crude prices, energy companies are cutting back on capital expenditures, drillers are reporting market softening and shale/tight oil and gas opportunities are attracting investment

## The Author

IMA provides market analysis and strategic planning advice in the marine and offshore sectors. Over 40 years we have performed more than 350 business consulting assignments for 170+ clients in 40+ countries. We have assisted numerous shipbuilders, ship repair yards and manufacturers in forming a plan of action to penetrate the offshore market. Assignments included advice on acquiring an FPSO contractor, forming an alliance to bid for large FPSO contracts, satisfying local content requirements, etc.

Tel: 1 202 333 8501  
e: imaassoc@msn.com  
www.imastudies.com

resources that otherwise might be used for deepwater projects. Time will tell how these positive and negative drivers combine to impact future orders in the sector. But it appears that a dampening impact is already being felt. Since the beginning of this year there have been orders for six production floaters – 4 FPSOs, an FLNG and a production barge. This is roughly in line with the average ordering pace over the past ten years – but in terms of increment to inventory the ordering pace has declined.

# FULL SPEED AHEAD



Caterpillar marine diesel engines deliver impressive performance throughout a wide speed range with exceptional power density. That means they're as smooth and efficient when you're pulling into dock at an idle as they are when you're heading up the river or out to sea at full throttle.

When it's time to "shove off" in a Cat® powered vessel, there's simply no holding back.

- Caterpillar offers the industry's largest range of marine engines to provide the power you need.
- High-performance or commercial, propulsion is in the name.
- The ease and speed of maintenance gets you quickly on the way.

- Cat marine generator sets and auxiliary engines keep things smoothly running onboard.
- Louisiana Cat is behind you all the way with fully equipped facilities, factory trained technicians, factory authorized warranty repairs and preventive maintenance programs.
- Long-term durability, high fuel efficiency and long life-to-overhaul provides maximum productivity with minimum outlay.

### 24-HOUR EMERGENCY PARTS AND SERVICE

Call our toll free number below to learn more about our Caterpillar products and services.



Bossier City

Morgan City

New Iberia

Port Fourchon

Prairieville



Louisiana CAT

© 2013 Caterpillar. All rights reserved. CAT, CATERPILLAR, their respective logos, "Caterpillar Yellow", the "Power Edge" trade dress as well as corporate and product identity used herein, are trademarks of Caterpillar and may not be used without permission.  
www.cat.com www.caterpillar.com

866-843-7440

www.LouisianaCat.com

## NEW &amp; NOTABLE

**KOC's New Damen Tug**

Photo: Damen

The Kuwait Oil Company's (KOC) new ASD Tug 3212 was launched at Damen Shipyards Galati, Romania. The contract consists of two vessel types, comprising nine units based on the Damen ASD 3212 model, providing 80t bollard pull, and five examples of the ASD 2810 design, providing 50t bollard pull. The new tugs will assist tankers at near shore loading terminals and at the new single point moorings further offshore. As such, they will also be equipped with FiFi systems.

**Trafuco 7 for Total Lubmarine**

Total Lubmarine named the newest addition to its fleet, Trafuco 7 at a ceremony at The Port of Antwerp. Trafuco 7 is a 795 cu. m. capacity barge divided into six compartments that will transport oils, system oils and trunk piston engine oils, including the Talusia, Aurelia, Atlanta and Disola ranges, with a minimum order of 2,000 liters per grade. The vessel will serve The Port of Antwerp, and will be operated using Total Lubmarine's Bioneptan and Biomultis biolubricants for the stern tube, bow thruster and deck equipment, while voluntarily adhering to the port's Environmental Ship Index (ESI) scheme.



Photo: Total Lubmarine

**Brazil Yard Delivers RAmports Tug**

Photo: Robert Allan Ltd.

Robert Allan said that Keppel Singmarine Brasil Ltda. (KSMB), of Navegantes, Brazil completed construction of the 24m SMIT Pareci, the second of a series of six Robert Allan designed RAmports 2500 tugs, for SMIT Rebocadores do Brasil (Rebras), of Rio de Janeiro. Robert Allan Ltd. worked with SMIT Rebras to develop this latest series, with significant changes including new engines complying with the latest IMO emissions standards, a new double drum towing winch and staple, a larger wheelhouse, a new streamlined skeg. Powered by a pair of CAT 3512C HD high-speed engines (1,379 kW @ 1600 rpm), this power is transmitted via a straight line shafting system to a pair of Schottel SRP 1012 fixed pitch azimuthing thrusters with 2100 mm diameter propellers in nozzles.

**Luxury Passenger Ferry**

Image courtesy BMT

BMT Nigel Gee (BMT), a subsidiary of BMT Group, and Ares Shipyard announced that the first two boats of a series of eight luxury passenger ferries destined for Qatar, have been completed and delivered to the customer. BMT worked with Ares Shipyard to produce an innovative design with attention to ease of construction. This has allowed the first two vessels to be delivered to the customer less than seven months after initial discussions on the project. The remaining six vessels will be delivered over the next four months with four currently in the building stage. The new boats are designed to transport guests to the new Anantara Doha Island Resort & Spa, 11km east of Doha. At 18m long with a beam of 6.7m, the composite catamaran design can carry up to 51 passengers. The vessel is capable of a maximum speed of 29 knots, and a service speed of 22 knots meaning that a typical passage from Doha to the resort will be in the region of 16 minutes.





**MJP CSU**  
1,341HP to 20,000HP power input

**MJP DRB**  
671HP to 3,350HP power input

**MJP ULTRAJET**  
135HP to 1,800HP power input

Go with the flow.



**Jet-160**  
160mm diameter (6.3")  
Up to 71HP

**Jet-180/185**  
180/185mm diameter (7.1"/7.3")  
Up to 102/126HP

**Jet-230**  
230mm diameter (9.1")  
Up to 250HP

**Jet-245**  
245mm diameter (9.6")  
Up to 320HP

**Jet-288**  
288mm diameter (11.3")  
Up to 450HP

**N67**  
6-Cylinder In-line, 6.7 Liter  
Max Output 570HP @ 3000rpm

**C90**  
6-Cylinder In-line, 8.7 Liter  
Max Output 650HP @ 2530rpm

**C13**  
6-Cylinder In-line, 12.9 Liter  
Max Output 825HP @ 2400rpm



**Motor-Services Hugo Stamp, Inc.**  
Authorized Distributor and Service Center

MSHS is an authorized distributor and service center for Marine Jet Power (MJP), AlamarinJet, and FPT. As a leader in the marine industry, MSHS is firmly committed to providing customers with high quality marine power and propulsion solutions. We offer complete propulsion packages for pleasure crafts and commercial vessels and our service team is available 24/7 for technical support and service. With offices in Florida, Louisiana, and Grand Bahama, MSHS has the inventory to manage the lifecycle of your propulsion and power equipment.

For more information on our authorized products and services, call 800-622-6747 or 954-763-3660 or visit [www.mshs.com](http://www.mshs.com).

**Motor-Services Hugo Stamp, Inc.**

Florida/Bahamas: +1 954-763-3660  
Louisiana: +1 504-265-8800  
Toll free: 800-622-6747  
[enginesales@mshs.com](mailto:enginesales@mshs.com)  
[www.mshs.com](http://www.mshs.com)



Visit MSHS  
MACC 2014  
Multi Agency Craft Conference  
June 10-12, 2014  
Virginia Beach, VA



**The Innovators in Fire Suppression since World War I.**

Our time-tested fire suppression systems protect a wide range of vessels and spaces including: Engine Rooms • Cargo Spaces • Galleys • Control Rooms • Lube Oil Rooms • Paint Lockers • Thruster Rooms • Switchgear Spaces • Machinery Rooms

Visit our website at [www.kiddmarine.com](http://www.kiddmarine.com) to find an authorized distributor in your area.



**KIDDE MARINE FIRE SUPPRESSION SYSTEMS**

**FIRE PROTECTION FOR PEOPLE AND PROPERTY**

# The Treatment of Foreign Seafarers



BY DENNIS L. BRYANT



(Photo: Alex Sergienko)

**T**he United States effectively treats foreign seafarers more harshly than any other group that enters the country without breaking the law.

The general rule is that all persons who are not U.S. nationals or permanent residents must have a visa to enter the United States.

Persons desiring to become U.S. citizens or permanent residents must obtain an immigrant visa. Most other persons desiring to enter the United States for a limited period of time must obtain a nonimmigrant visa. To obtain a nonimmigrant visa, one must have a valid passport and complete the Nonimmigrant Visa Application, Form DS-160 and submit it and a photograph (head shot) to the relevant U.S. embassy or consulate.

The applicant must then schedule an interview, but the interview is generally required only for persons between the ages of 14 and 79.

An application fee of \$160 must be paid prior to the interview. In many cases, there is also a visa issuance fee. But some nationalities may be eligible for more favorable treatment.

The Visa Waiver Program (VWP) allows citizens from participating countries to travel to the United States without a visa for stays of 90 days or less.

Such travelers must be eligible to use the VWP and have a valid Electronic System for Travel Authorization (ESTA) approval prior to travel. The traveler's purpose must be permitted by a Visitor (B) Visa (e.g., tourism or various business purposes). Travel must be performed on an approved air or sea carrier and the traveler must have a round trip ticket indicating return passage to a country outside the United States that is a participant in the VWP. Currently, there are 38 participating VWP countries.

# SERIOUS TRAINING FOR SERIOUS MARINERS.



## Our up-to-the-minute, industry-leading training includes:

- **Dynamic Positioning (DP)** – Our state-of-the-art DP lab offers operators basic and advanced courses for fully integrated hardware training.
- **ECDIS** – Our lab has the latest ECDIS hardware, bringing students real world training on real world equipment.

- **AB to Mate (OICNW) and Chief Mate Master** – MPT has the options you need, from the full range of courses to just the assessments.
- **Over 100 Approved Courses** written to meet the IMO Standards for unlimited and limited tonnage.

It's time to discover why MPT is the most complete full-service private maritime training school in the country. Our ongoing investment in S.M.A.R.T. simulation provides a visually immersive level of realism not available in other programs. For training that can create serious opportunities, call us or visit [MPTusa.com](http://MPTusa.com) today.



## MPT

MARITIME PROFESSIONAL TRAINING  
Fort Lauderdale, Florida

1915 South Andrews Avenue - Ft. Lauderdale, FL 33316

Ph: +1.954.525.1014 - Fax: +1.954.764.0431

[www.MPTusa.com](http://www.MPTusa.com) - [info@MPTusa.com](mailto:info@MPTusa.com)

*Approved For Veterans' Training*

Assuming that the terrorist demonstrates the requisite skills and gets hired on an ocean-going merchant vessel, the individual must wait for the vessel to make a U.S. port call, which is certainly a long-shot within the six-to-12 month period on a particular vessel. **No self-respecting terrorist or terrorist organization would select the maritime option as an efficient means of getting a malefactor into the United States.**

These countries include all the EU and EEA members, plus Australia, Brunei, Japan, New Zealand, Singapore, South Korea and Taiwan.

Citizens of Canada and Bermuda do not require visas to enter the United States for visit, tourism and temporary business travel purposes. Also, citizens of Canada and Bermuda do not require visas to enter the United States for purposes of travel as a crewmember. Citizens and permanent residents of Mexico generally must have a nonimmigrant visa or a Border Crossing Card (also known as a "Laser Visa"). For ease of travel, the B-1/B-2 visa and the Border Crossing Card have been combined into one document (DSP-150).

A Crewmember Visa (D-1) must be obtained by persons working on board vessels or international airlines entering the United States if the individual intends to depart the vessel or airliner (even for short periods) while it is in the United States. The process for obtaining a Crewmember Visa includes all the requirements for obtaining a regular nonimmigrant visa. In addition, the applicant for a Crewmember Visa must provide evidence of the purpose of the trip the intent to depart the United States after the trip, and the ability to pay all costs of the trip if applicable. Evidence of family ties in the applicant's home country may suffice for showing the intent to depart. The Visa Waiver Program is not applicable to entry as a crewmember, but (as noted above) citizens of Canada and Bermuda do not require visas to enter the United States for purposes of travel as a crewmember.

Commercial airlines have scheduled routes. In addition, airline crewmembers tend to stay with the same airline for extended periods. Therefore, crewmembers on foreign airlines that call at U.S. airports know with certainty that they will need Crewmember Visas. The same cannot be said of most merchant vessels. They have no scheduled routes in most cases and sometimes change destinations en route. Many merchant mariners are employed by the same maritime employer for only one year at a time; long-term employment contracts are the exception rather than the rule on the marine sector.

A merchant mariner on a foreign vessel, in most cases, has no idea whether the vessel will call in a U.S. port during the six-month period during which a Crewmember Visa is valid. Therefore, most merchant mariners do not go through the time and expense required to obtain such a visa.

An example (from the pre-9/11 era) may illustrate the visa conundrum. A ship's officer from a visa waiver country was assigned to join his ship in a U.S. port. He received the assignment several weeks in advance and decided to visit the United States as a tourist during the period before he was to join the ship. After two weeks of touring the U.S., he joined the ship as scheduled. The U.S. immigration officer for the ship noted his arrival and promptly informed the master that a civil penalty would be assessed if this particular ship's officer went ashore for any reason. I was attending a major shipping conference in Washington, DC shortly thereafter. During a Q&A with the Deputy Chief Counsel of the Immigration and Naturalization Service (INS), a senior representative of the shipping company involved related the above and asked why this individual presented no threat to the United States during the two weeks that he toured the country, but was suddenly a threat when he boarded his ship. The INS representative's reply was that tourism and crewmember issues were entirely separate programs. In other words, common sense was and is not applicable.

When cargo (merchandise) from outside the United States is bound for unloading in the U.S., advance notice of the particulars concerning the cargo is transmitted to the U.S. Government. Every cargo is screened. If the cargo is deemed suspicious, it undergoes scanning and possibly other individualized examination. Less than 10% of cargo coming to the United States is subjected to this enhanced examination. In other words, more than 90% of the cargo coming to the U.S. is deemed to not present a security threat and is admitted through routine processing, based largely upon the paperwork related to cargo.

The U.S. Government is also provided advance notice of all crewmembers on

all ships bound for a U.S. port. The advance notice of arrival must include, for each crewmember, the individual's full name, date of birth, nationality, passport or mariner document number, position or duties on the vessel, and where the crewmember embarked. This information is then compared against an extensive database of known and suspected terrorists and similar undesirables. If the individual is determined to be a severe threat, the vessel can be barred from entry into U.S. waters while the individual remains on board. If the threat is deemed less serious, the vessel must hire armed guards to keep the individual from departing while the vessel is in U.S. waters. Even if a crewmember presents no known threat, he or she may not depart the vessel (generally may not even come down the gangway to check draft marks or to make a telephone call from a landline) unless that individual has a U.S. Crewmember Visa. In other words, unlike with cargo where a particular piece of cargo is deemed unthreatening unless shown otherwise, a crewmember without a U.S. Crewmember Visa is deemed a threat to the security of the United States if he or she steps ashore even for a moment. A passport (even from a country that participates in the Visa Waiver Program) is insufficient. Likewise, possession of a seafarers' identity document issued in accordance with the ILO Seafarers' Identity Documents Convention will not suffice.

For all practical purposes, the United States treats foreign seafarers as threats to the security of the U.S. unless and until that seafarer has jumped through various bureaucratic hoops. Those hoops are effectively impossible for most foreign seafarers to negotiate. Thus, foreign seafarers are substantially denied the ability to take liberty or shore leave when their ships call in U.S. ports. It is ironic that the United States Government allows these same seafarers to navigate large vessels loaded with oftentimes hazardous cargoes through U.S. waterways and to call at and unlash/lade in U.S. ports. The threat potentially presented by these ships and their cargoes appears far greater than that presented by an individual crewmember without a U.S. Crewmem-

ber Visa, but I am unfortunately getting logical.

There are a variety of means by which a terrorist might enter the United States to wreak havoc. The 9/11 terrorists all obtained tourist visas and then flew to the U.S. on commercial airliners. A terrorist could join the numerous economic migrants who successfully cross the southwest border each year. Alternatively, a terrorist could walk across the unguarded border with Canada. If a terrorist opted to try to enter the United States as a foreign crewmember, the process becomes more complex and uncertain. The individual would have to undergo at least rudimentary training so as to qualify as a seafarer. Failure to have some basic skills will generally prevent one from getting hired. If hired, being unskilled will likely lead to quick dismissal. Assuming that the terrorist demonstrates the requisite skills and gets hired on an ocean-going merchant vessel, the individual must wait for the vessel to make a U.S. port call, which is certainly a long-shot within the six-to-12 month period on a particular vessel. No self-respecting terrorist or terrorist organization would select the maritime option as an efficient means of getting a malefactor into the United States.

Approximately 90% of goods imported to the United States from overseas arrives by ship and, of that, over 95% arrives on foreign-flagged ships manned by foreign crewmembers. If imported cargoes were treated like foreign crewmembers, the U.S. economy would grind to a halt. Fortunately, there is a strong lobby in Washington, DC to ensure that foreign trade is expedited. There is no such lobby in Washington for foreign seafarers.

## The Author

Dennis L. Bryant is with Maritime Regulatory Consulting, and a regular contributor to Maritime Reporter & Engineering News as well as online at MaritimeProfessional.com.

t: 1 352 692 5493  
e: dennis.l.bryant@gmail.com

# Hydrodynamic Software Suites

## Making Design Concept Evaluation More Efficient

BY ARNO BONS

To support designers and engineers in evaluating design concepts more efficiently, MARIN has developed the hydrodynamic suites QSHIP and QPROP.

Hydrodynamic considerations have a great impact on the operational performance of a ship during its lifetime. For this reason, it is important to integrate hydrodynamic analyses as early as possible into the ship design phase. Improving powering, seakeeping and maneuvering performance may have a major impact on design aspects such as the capabilities and General Arrangement plan. Improving hydrodynamic performance at more advanced stages of the design is hardly possible. This led MARIN to develop the hydrodynamic suites QSHIP and QPROP.

Both QSHIP and QPROP are Quaestor based, which is a computational modeling system applied in a variety of design and analysis applications in the shipbuilding and offshore industry. The workflow of MARIN's Quaestor-based suites provides guidance and ease-of-use for complete chains of pre-processing, hydrodynamic calculations and post-processing.

**QPROP is an advanced propeller design and analysis suite.** The required resistance and propulsion characteristics for the displacement ships are predicted by the integrated DESP program. DESP predictions are based on formulas obtained from regression analyses on data from MARIN model experiments and sea trials.

QPROP greatly reduces the time spent on iterative propeller design, analysis and reporting activities as all of the incorporated tools make use of the same pool of project related input data and (intermediate) results.

**QSHIP forms a workflow around the frequency domain program SHIPMO for the prediction of ship motions in a seaway.** SHIPMO is based on 2D linear diffraction theory – known as strip theory - and theoretical empirical formulations of the viscous roll damping co-

efficients. The Response Amplitude Operators (RAO), as a result of a SHIPMO calculation, can be visualised with the RAO viewer, which is also included in QSHIP. With the integrated, Operability

Viewer the user can easily see the effects of climate, sailing direction, speed and any predefined criteria.

Both suites provide automated data exchange between the included software

and reduce the time-to-market for new designs. With hydrodynamic tools, designers can focus on analysing a variety of design concepts in a convenient and efficient way.



### OPTIMISED OPERATIONS

Inmarsat brings unrivalled high-reliability, premium quality global voice and data connectivity. This facilitates ultra-reliable ship-to-shore communications, linking shore side experts to your crew and seamlessly connecting your office with your fleet.

### ENABLING TECHNOLOGIES

The iFUSION platform brings a revolution in enhanced commercial maritime fleet technology management. The new industry standard, this open architecture vessel technology suite reduces operational overheads and enables bespoke IT integration.

### MANAGED SERVICE

With Inmarsat, you're not just getting cutting-edge maritime connectivity and technology, you have the backing of a global team of highly skilled technicians with over 30 years maritime experience. They advise on end-to-end network agnostic solutions that help you optimise your maritime business.

# SAFER SMARTER SHIPPING

## The Author

Arno Bons is senior project manager at the Maritime Simulation & Software Group of MARIN, the Maritime Research Institute Netherlands.

e: [a.bons@marin.nl](mailto:a.bons@marin.nl)  
[www.marin.nl](http://www.marin.nl)



Inmarsat offers your ship a highly evolved maritime communications ecosystem which makes every trip or voyage more efficient, safer and more productive. In short, just a lot smarter. Visit [inmarsat.com](http://inmarsat.com)

**inmarsat**  
maritime

# SEEMP Potential win-win for commercial vessels

**SEEMP can make a fleet more competitive in a difficult business environment while reducing its impact on the environment.**

BY JOSE FEMENIA, P.E.

In January 2013, the International Maritime Organization (IMO) put into force new regulations intended to improve the energy efficiency of ships over 400 gross tonnes (gt) on international voyages, including a requirement to keep on board a ship-specific Ship Energy Efficiency Management Plan (SEEMP). This initiative is intended to reduce ship greenhouse gas (GHG) emissions by encouraging ship operators to reduce energy consumption.

Since that time, there has been much discussion within the shipping industry

about the potential domestic enforcement of the SEEMP.

Recently, the U.S. Coast Guard (USCG) expressed its intention to enforce the IMO SEEMP requirement for vessels over 400 gt on international voyages during vessel boarding by checking to see that the vessel has an up-to-date SEEMP. If the SEEMP does not exist or is outdated, the USCG intends to notify the U.S. Environmental Protection Agency.

Currently an SEEMP is not a domestic requirement for U.S. flagged vessels en-

gaged solely in U.S. trade.

Although the SEEMP does not have any formal enforcement measures, it is in the best interests of ship owners and operators to develop and implement a plan by monitoring the vessel's energy efficiency, improving existing operations and implementing new energy-efficiency technologies as they become available and are appropriate to the vessel.

In doing so, they will be able to reduce costs and improve operating margins while reducing the environmental impact of GHG emissions.

## Improving ship design and operation

The new regulations were adopted in 2011 under the International Convention for the Prevention of Pollution from Ships (MARPOL). These regulations have two components:

- **The Energy Efficiency Design Index (EEDI)** requirement specifies GHG emissions limits to be met or exceeded for new ship construction.
- **The Ship Energy Efficiency Management Plan (SEEMP)** requires ships to have an energy-efficiency management plan aboard.

For news and background on the development and promulgation of these regulations, visit <http://www.imo.org/MediaCentre/HotTopics/GHG/Pages/default.aspx>.

The IMO considers CO<sub>2</sub> to be a greenhouse gas and recognizes the fact that the amount of CO<sub>2</sub> generated per kilowatt of power produced depends on the efficiency of the heat engine (diesel, gas turbine or steam turbine) and the hydro-

gen-carbon ratio of the fuel (heavy fuel oil having a lower ratio than natural gas). Accordingly, the IMO's Marine Environment Protection Committee (MEPC) has chosen fuel consumed per unit of effective transport work as the measure of unit GHG emissions.

The EEDI uses a comprehensive equation to calculate a targeted consumption quotient [g/(unit-work)] as a standard for ship designers and owners to meet or better during the vessel's design phase. In recognition of improving technologies, the EEDI efficiency target energy consumption (CO<sub>2</sub> emissions) get more stringent with time.

Implementing the required SEEMP is a four-step process as outlined in IMO's "2012 Guidelines For The Development Of A Ship Energy Efficiency Management Plan" (MEPC 63/23 Annex 9). The four steps for developing a ship-specific SEEMP are as follows:

- **Planning**  
The planning process includes determining the current status (baseline) of the ship's energy usage and the expected energy efficiency to be gained by implementing the plan.
- **Implementation**  
Implementation of the energy improvement process described in the planning process includes defining the person(s) in charge of implementation and the incorporation of a record-keeping system that will be beneficial for self-evaluation.

- **Monitoring**  
The ship's energy efficiency should be quantitatively monitored using an established method. The guidelines note that continuous and consistent data collection

## Are Stray Electrical Currents Destroying Your Machinery?

Sohre SHAFT GROUNDING (EARTHING) BRUSHES are used on propeller shafts, turbines, generators, electric motors, gears, pumps, etc. Failure to properly ground (earth) rotating shafts can result in expensive damage to seals, bearings, or other critical components.

"TOOTHBRUSH" TYPES "LW", "L" & "S" (SCHEMATIC)

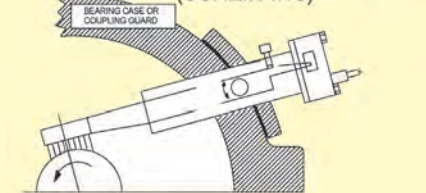

- Self Cleaning
- Operate dry or with oil
- Gold/silver bristles
- Working parts are removable during operation
- Brush internals are insulated from casing
- Voltage and current monitors are available
- Little or no maintenance

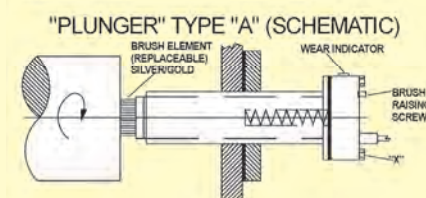

© 2013 Sohre Turbomachinery, Inc.

**SOHRE TURBOMACHINERY® INC.**

Monson, Mass., USA 01057 • Tel: (413)267-0590

INFO@SOHRETURBO.COM • WWW.SOHRETURBO.COM

is the foundation of monitoring; however, they also state that over-burdening of the ship's crew should be avoided.

- **Self-evaluation & improvement**

This stage is intended to produce meaningful feedback for the next planning cycle.

It should be stressed that the SEEMP is a continuous process wherein the plan is periodically updated as feedback is received and factored into the process.

- **Continuous monitoring without "additional burden"**

Continuous monitoring of the vessel's energy consumption is both a requirement of SEEMP and a practical prerequisite to improving energy efficiency and reducing operating costs.

The IMO recognizes that adding more data collection and record-keeping responsibilities to already overloaded shipboard crews can be counterproductive and potentially dangerous. Not only do the 2012 SEEMP guidelines caution against over-burdening the crew with data collection and continuous monitoring, they also suggest that the information should be transmitted, stored and analyzed ashore.

Fortunately, the shore-side facilities and utility industries have been using energy-efficiency management plans for decades and, in most cases, the technology developed for shore-side can easily be transferred to the maritime industry. Continuous energy monitoring and verification firms have been collecting and monitoring energy use in facilities such as large building complexes, hospitals and power plants, in some cases, for decades.

They have reported the collection and monitoring results to plant operators and owners and, when appropriate, their engineering staff has alerted the operators of issues that needed immediate attention. They have also suggested cost-effective ways for operators and owners to improve performance and save money — both by improving existing operations and through cost-effective equipment upgrades.

Similarly, a commercial or passenger fleet owner can contract with a third-party marine monitoring and verification service for continuous onshore monitoring and analysis of real-time data sent over the web from the vessel's onboard machinery plant control and monitoring system (MPCMS). Ship system data may include main engine performance and fuel consumption, the ship's HVAC system and electrical generation for hotel load. Daily fuel consumption

and voyage reports enable the owner to make informed fuel purchasing decisions based on historical and forecasted operations, validate emission regulation compliance, and verify the performance of energy-efficiency initiatives.

- **The Value of SEEMP**

Owners and operators should not view complying with SEEMP as another regulatory burden; rather, it should be viewed as a plan for lowering energy consumption and lowering fuel costs. For owners of existing chartered vessels, defining and implementing SEEMP most likely will justify an increased charter rate; for ship operators, improved vessel energy efficiency means savings on fuel and associated costs.

To be truly energy efficient, operators should look beyond the vessel's overall fuel consumption and the transport work performed by the vessel. They should look past the low-hanging fruit available to reduce fuel consumption — reducing ship speed, propeller polishing, hull coatings and/or cleaning, etc. They should also examine non-propulsion power energy uses, such as balance of plant loads, hotel loads including air conditioning and cargo related loads. This is especially important for vessels that have a very large hotel load, such as cruise ships, and for vessels operating at reduced speeds.

Remember that when vessels are operated at reduced speeds, the non-propulsion component of the total energy consumption is a greater fraction of the total.

When properly implemented and used, SEEMP will empower owners, operators and crews with the knowledge required to make cost-effective decisions to save energy and reduce operating costs. In particular, when monitoring is expanded to record how the energy is used within the vessel, it will enable them to understand the vessel's energy consumption trends and take or plan additional energy-efficiency measures.

If the crew is relieved of the burden of continuous data collection and record keeping, they are likely to view the SEEMP as a positive development since it will give them — especially the chief engineer and the master — a tool to better operate the ship.

Ultimately, the marine industry as a whole may come to view the SEEMP not only as another set of regulations, but as a way to make our fleet more competitive in a difficult business environment while reducing the industry's GHG impact on the natural environment.

## The Author

Jose Femenia is the former Engineering Department Head and director of the Master of Marine Engineering Program at the United States Merchant Marine Academy and Engineering Department Chairman at the SUNY Maritime College. Femenia now serves as a consultant at utiliVisor, which provides comprehensive energy monitoring and advisory services for the marine industry. He is a licensed professional engineer.

## Professional ECDIS solution

X

## Professional Radar solution



**JMA-5300MKII**  
High-Performance Radar

### Constaview™ digital signal processing

The most powerful processor ever

### TEF™ multi-level target enhancement

Advanced technology for clear echo indication

### Enhanced trail modes

Selectable trail length, great collision avoidance aid

### Intuitive and advanced user interface

Clear and ergonomic on-screen information

### Brushless motors

Extending the lifetime of motors



### JAN-2000

IMO Type Approved ECDIS

### Intuitive user-interface

Featuring multi/wide-view mode

### Real-Time AIS and Navtex overlay

Symbol and message indication

### In-house technology

Anti-vibration design, silicon disk

### Advanced route planning

Easy to edit, save and import routes

### Flexible black box configuration

Suiting your type and size of vessel

*Feel connected. Communicate further.*



Since 1915  
JRC Americas  
(p) 205 654 5644  
www.jrcamerica.com



# Ergonomic Controls

## Innovation for ECDIS, Bridge Controls

BY MARK LIU

Innovations in computer display technology would seem to have recently hit a plateau. With the advent of LCD panels, improvements in computer displays have recently been limited to larger screens, higher pixel resolution, greater energy efficiency, and lighter, more efficient use of base resources. Yet there remains two areas where computer display manufacturers can continue to offer improvements: the human-machine interface, and local display intelligence.

To offer the most effective solutions, improvements should maximize their utility with improvements in performance for specific environmental conditions. There are several features a computing display can bring to embedded computing stations aboard ships, or ocean platforms; in particular, the two most glaring problems for users when out at sea are low-light environments, and the technical ignorance of the average user when faced with crashes or

machine malfunctions. Advances in the display interface can lessen the effects of these problems and much improve the user experience.

### A Wave of the Hand: Precision Sight

First, let us consider what most bridge computing stations are like; for instance, this might be an ECDIS charting station that could potentially be accessed at any time of the day or night. This would mean that the display brightness would be con-

stantly adjusted according to the time of day and environmental conditions under which it is being used. During the day, the brightness would be much higher; at night, much lower. Daytime viewing is not a worry: it's the standard. Yet the other brightness levels, for the rest of the day, are specifically addressed within the ECDIS standard: it requires that any ECDIS type-approved display must be capable of rendering accurate colors at three different brightness intensities.

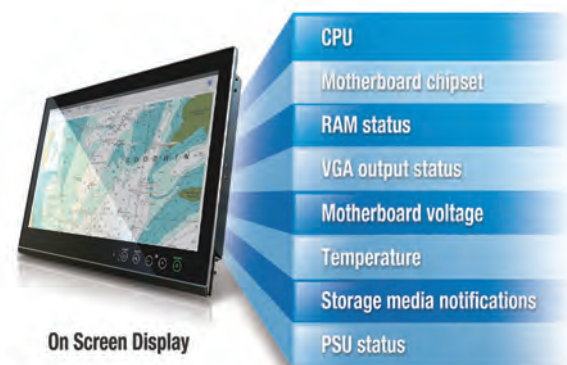



### ECDIS-Certified Comfort

These carefully defined intensities demonstrate that the ECDIS standard was created, first and foremost, to have a convenient means of adjusting these intensities on-the-fly. When facing a large, bright screen in near-darkness, finding the precise location of the controls on an LCD panel can be problematic. To address this issue, the controls may be backlit, and equipped with a proximity sensor. With a simple wave of the hand in the controls' general area the machine interface will light up, allowing the operator to easily and quickly re-set the brightness level to his or her desired intensity. Additionally, for an ECDIS station, the controls should offer presets that automatically adjust the display to one of the three type-approved, color-calibrated intensities stipulated by the ECDIS standard.

### Making Things Easier

Because this is a bridge environment, typical users who depend on these displays will not be trained in troubleshooting system failures; additionally, a display failure would be, in terms of the system it is serving, catastrophic. To address situations where the display or computing system fails, a BIOS level diagnostic utility may be provided. By integrating the diagnostics at the BIOS level, the display will be able to generate a quick rundown of subsystem integrity for any user who requires it, at any time.

Imagine, for instance, a navigator who arrives on the bridge to lay out a chart. This navigator turns on the ECDIS station, but for some reason the display fails to light up as it should. Clearly there is something wrong, but faced with a dark screen and a fully integrated, closed ECDIS station, there is no way to discover what the problem might be without opening up the cabinet and digging through the internals. However, by pressing an Information button located among the monitor controls, the display terminal's on screen display (OSD) immediately lights up with a quick rundown of the main computer subsystems: CPU, motherboard chipset, RAM status, VGA output status, motherboard voltage, temperature, storage media notifications and PSU status. Our average user—utterly untrained in computing system or networking administration—is made immediately aware of what the problem is, and whether or not it can be fixed elsewhere. Issues such as memory or PSU integrity might be able to be solved with a simple component substitution or re-wiring. Issues with the motherboard,

CPU, or other hardwired components clearly indicate that the problem can only be fixed once the ship reaches port. However, armed with this information, the captain may now call ahead, file a report and have a service technician ready and waiting with a replacement product

or with the necessary components for bringing the system back on line.

### No Failure Will Get By Unnoticed

Clearly there remains room for improvement in display technology. By addressing the needs of specific indus-

tries and specific embedded computing requirements it is possible to deliver significant improvements that both the end-user as well as system integrators, designers, and technicians will appreciate.

*Mark Liu, product manager at Moxa.*



# RELIABLE POWER

## WHEN THE WEATHER IS NOT

### Powering the industry for 60+ years

- + Control Systems Repair & Installation
- + Switchgear Design & Installation
- + Engineering Services
- + Electrical & Corrosion Surveys
- + Power Distribution Systems Design & Installation
- + Fire Inspections
- + Installation & Sales of Electrical Components
- + Electrical Systems Repair
- + Panel Production & Design



Ft. Lauderdale, FL + 954.523.2815  
Riviera Beach, FL + 561.863.7100  
Toll Free: 800.545.9273  
[www.WardsMarine.com](http://www.WardsMarine.com)  
Se Habla Español



**WARD'S**  
MARINE ELECTRIC

[@WardsMarine](https://twitter.com/WardsMarine) [/WardsMarine](https://facebook.com/WardsMarine) [LinkedIn](https://linkedin.com/company/WardsMarine)

# To Litigate or Arbitrate That is the Question



BY ALAN M. FREEMAN

**M**ore than once, I have been asked to resolve a dispute in which my client was surprised to learn either that it could not force the other side into arbitration, or that arbitration was very different from its expectations.

Many companies devote hours (if not weeks and months) to negotiating what they consider to be the “substantive” terms of a contract, yet they pay little attention to the dispute resolution clause often included among boilerplate terms at the end. This is a risky practice, for rights that are carefully bargained for may effectively be lost if the “right” dispute resolution procedure is not negotiated at the outset.

When it comes to dispute resolution clauses, there is no one-size-fits-all solution. That which makes sense in one contract may not be appropriate for another, and the decision whether to arbitrate or litigate may be more complex than anticipated. The temptation to “cut and paste” should be resisted. Instead, those negotiating the agreement must fully understand the dispute resolution options available, and their implications in different contexts. This is particularly critical with respect to mandatory arbitration, for although the rules governing courtroom procedures generally are pre-established and not subject to negotiation, arbitration is a creature of contract, and the parties are able to determine many of the procedures even before a dispute arises. The ability to negotiate those procedures up-front can be a gold mine for the astute, and a minefield for the uninformed.

Detailed here are several threshold issues that must be explored when negotiating a dispute resolution clause, and several options that might be considered.

## *How important is specialized knowledge?*

Perhaps the greatest potential benefit of arbitration is the ability to select the person(s) who will resolve the dispute. This is important because judges and juries are not likely to have expertise in the maritime transportation industry, and they may have no experience operating a business. This may not be important in some cases; but in others, technical competence will be important to understanding the evidence and resolving the dispute. For example, shipbuilding contracts, technical management contracts, and charters often incorporate mandatory arbitration clauses precisely because judges and juries are unlikely to possess the knowledge and experience necessary to evaluate the evidence and reach the “right” conclusion—at least not without substantial briefing by counsel, and testimony by experts. In such cases, arbitration before one or more industry experts may provide a more efficient and satisfying result.

Thus, some charters require arbitrators to be “commercial men,” which excludes attorneys. And there are arbitration solutions specifically tailored to the maritime industry (e.g., the Society of Maritime Arbitrators, Inc.), which offer both technical expertise and a forum for resolving cross-border disputes in which neither side is perceived to have a “home court advantage.”

Although arbitration may be preferred by maritime industry operators in some contexts, this does not mean that it offers the best solution in all contexts. Even a shipyard has business relationships (such as with catering and security firms) that could lead to disputes that would not require any particular industry expertise to resolve.

## *How important is confidentiality?*

A compelling advantage of arbitration is the option to keep proceedings confidential. Although there are contexts in which an arbitration decision can eventually make its way into a courtroom, generally neither the parties’ filings nor arbitration hearing are a matter of public record, and a well-crafted arbitration clause can require that the parties keep their dispute and its resolution confidential. This can provide great value to a company that prefers to avoid publicity or fears developing a reputation as a litigious actor or easy target. Further, the ability to keep dispute resolution proceedings confidential can be critical when the dispute involves commercially sensitive matters, such as business strategy, cost and pricing models and the like.

Confidentiality is not always desirable, and there are exceptions. For example, decisions of the Society of Maritime Arbitrators generally are published, although parties can agree to full or limited confidentiality. This issue should be considered at the outset, and not postponed until a dispute has arisen.

## *How important is cost?*

Minimizing legal expense is always important, but the issue merits focused attention when selecting a dispute resolution procedure. Although arbitration often will be less expensive than litigating in court, that will not always be the case.

Arbitration costs that would not arise in a courtroom include hourly fees for the arbitrators, as well as the arbitral forum’s own case administration fee. Depending on the number and qualifications of the arbitrators and the amount in dispute, these fees can escalate rapidly.

In contrast, judges presiding in a courtroom are not paid by the parties, and the courthouse filing fees generally pale in comparison to those assessed in arbitration. The difference may not be a deciding factor in most cases, but it is worth considering nonetheless.

Of greater significance is the common misperception that arbitration will minimize attorney fees. Perhaps, but perhaps not. Often, discovery of documents and persons is narrower in arbitration because arbitrators are not constrained by codified rules of evidence and procedure. That alone can provide substantial cost savings, which would justify a preference for arbitration. Similarly, the motions practice that often attends courtroom litigation is frequently more limited in arbitration. But some courts have a reputation for placing the same sort of limits on discovery and motions practice that are often employed in arbitration, and in these courtrooms litigation may be as cost-efficient as arbitration. (The federal court in Alexandria, Virginia is known as the “Rocket Docket” for a reason).

Arbitration proceedings are creatures of contract, and the parties are able to negotiate what the process will look like. In some cases, you may wish to negotiate the extent of available discovery rights. For example, in a complex dispute the parties may agree to the same expansive discovery rights that would apply in court because they fear that artificial constraints would prejudice their ability to succeed on the merits. The same is true of motions practice: although arbitration procedures often limit (in the name of efficiency) the parties’ ability to file dispositive motions, the parties may wish to negotiate such a procedure. Indeed, one colleague recently complained

Although arbitration may be preferred by maritime industry operators in some contexts, this does not mean that it offers the best solution in all contexts.

that arbitration had provided an unsatisfying result when a client was not able to file an early motion to fully dismiss a frivolous claim, as it would have in court.

The salient point is this: arbitration may be less expensive than courtroom litigation, but that will depend on the specific arbitration procedures to which the parties might agree, contrasted against those that would be employed by the judicial alternative. Focusing on this issue at the outset is therefore critical.

### ***How important is a quick result?***

Most federal and state court dockets are congested, and thus the ability to obtain a speedy resolution can be a significant advantage of arbitration. In fact, some arbitration agreements require the arbitrators to resolve matters within short deadlines, and many arbitrators consciously meet that expectation.

That said, arbitrations can proceed just as slowly as courtroom litigation when the issues are particularly complex, when the parties are numerous and/or dispersed, and when the parties have agreed to court-like pretrial procedures. Furthermore, litigation in some courts (such as the aforementioned “Rocket Docket”) may proceed more quickly than arbitration because the judges in those courts will brook no delays and grant no extensions (except in the most unusual of circumstances).

Thus, when expediency is an issue, careful attention must be paid to forum selection.

### ***How will the dispute be resolved?***

One oft-overlooked distinction between arbitration and litigation is the basis for the outcome. In litigation the judge is constrained to rule based on the law, as set forth in statutes, regulations, procedural rules and prior judicial decisions. But arbitrators have greater flexibility; they may consider the same statutes, regulations, rules and prior decisions, but they also have discretion to consider evidence that would be ex-

cluded in a courtroom, and to reach a decision they perceive to be fair, even if it is not fully consistent with a strict application of the law. While this may work to your advantage in some cases, it may generate substantial uncertainty.

Are you waiving the right to an appeal? Judges make mistakes and when they do, they are subject to appeal. That procedural safeguard can provide critical value. In contrast, the grounds upon which an arbitrator’s decision may be appealed are more limited.

Unless you think the “basis for decision” factor weighs heavily in favor of proceeding in court, remember that arbitration avoids the risk of a “runaway jury” and it minimizes exposure to unwarranted punitive damages.

### ***Is the dispute likely to involve an ongoing relationship?***

Another frequently overlooked issue is whether a dispute is likely to involve an ongoing business relationship. In such cases, arbitration can provide an intangible benefit because the process can be less formal and involve fewer opportunities for adverse encounters (e.g., depositions), which lends itself to being more collegial and less adversarial than courtroom litigation. This is not always the case, of course, but when the parties are likely to continue doing business together arbitration may be more conducive to maintaining that relationship.

The questions posed here are not exhaustive, nor are the thoughts offered in response. They should, however, demonstrate the complexity of an issue often overlooked in contract negotiation and the importance of addressing that issue head-on.

## **The Author**

Alan M. Freeman is a partner in the Washington, D.C. office of Blank Rome LLP. His business litigation and legal risk reduction practice is national in scope.

t: 202-772-5925

e: [Freeman@BlankRome.com](mailto:Freeman@BlankRome.com)

# **CLICK BOND®**

## **ADHESIVE-BONDED FASTENER TECHNOLOGY**

- Reduces Cost by Eliminating Hot Work and Gas Freeing
- Maximizes Design and Work Sequence Flexibility
- Facilitates and Simplifies Repairs at Sea
- Protects Against Galvanic Corrosion

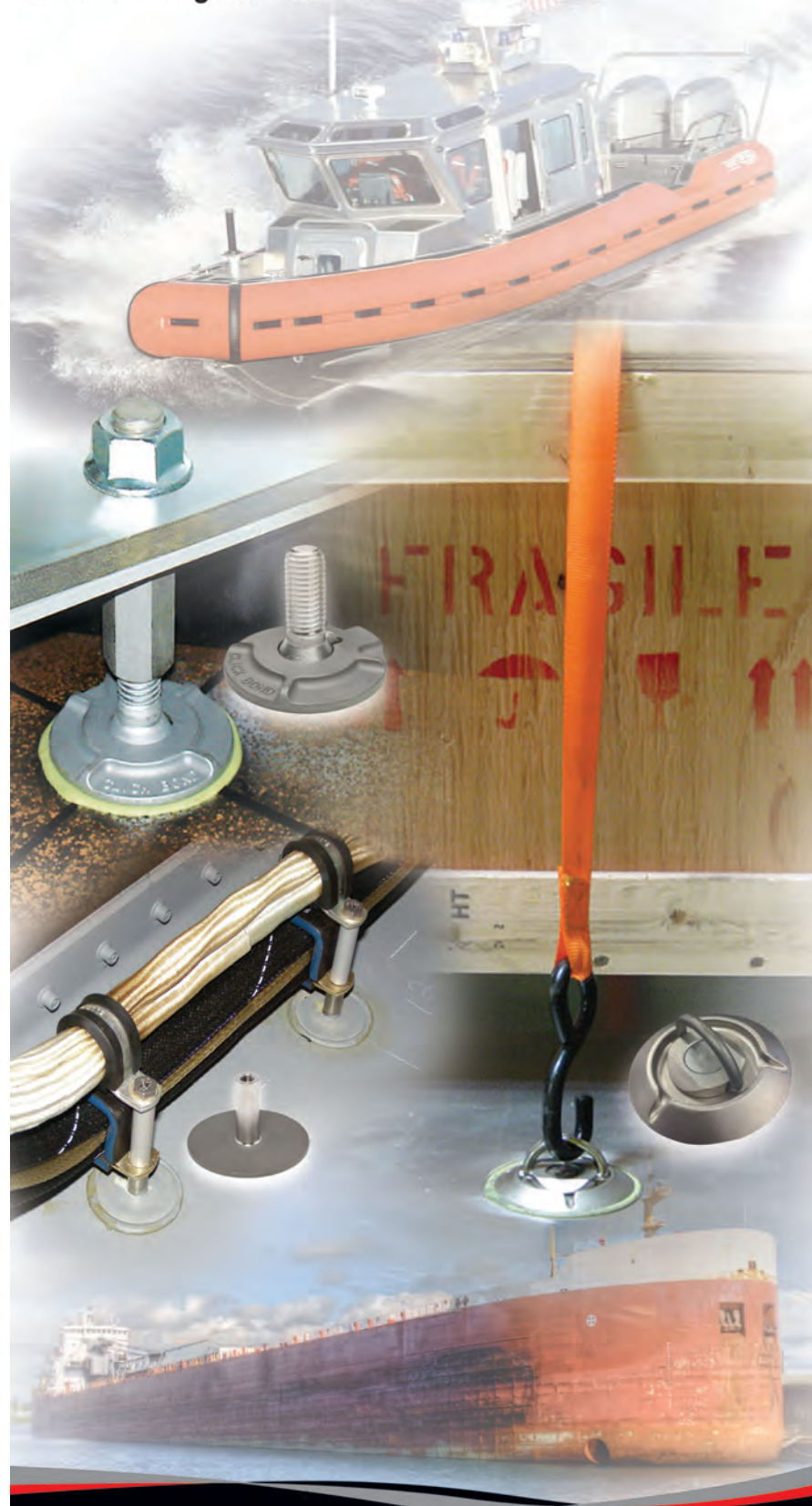

**PIONEERING > ADVANCED > SOLUTIONS**

2151 Lockheed Way Carson City NV 89706 +1-775-885-8000 [CLICKBOND.COM](http://CLICKBOND.COM)



# SEWOL

## Another investigation of another tragic maritime casualty begins

By Greg Trauthwein

**W**hile the investigation is still fresh regarding the sinking and the tragic loss of life of the South Korean ferry *Sewol*, early reports point to a multitude of potential problems, including a critical breakdown among the crew. As work continues to secure the ship and recover the remaining dead onboard, Maritime Reporter & Engineering News reached out to maritime training and education experts for insights on that sector's role in helping to reduce the risk of disaster at sea.

By now the grim details of the sinking and tremendous loss of life aboard the South Korean ferry are well-known, and the name "Sewol" will live in infamy in the maritime history books. Though all maritime mishaps with loss of life are tragic, and there have been far bigger wrecks with many more dead, this one struck a particular nerve in that of the 476 passengers and crew onboard, 339 were children and teachers on a high school outing for what was planned as a routine sailing from the Port of Incheon to the southern island of Jeju. It will be months if not years before the final chapter on Sewol is written, and perhaps

the tale will never fully be told. But in the immediate aftermath, more than 300 remain missing and presumed dead and Captain Lee Joon-seok and many of his crew are in jail, there are more questions than answers. With early focus and outrage set squarely on the actions of captain and crew, we focus here on the role of the maritime training and education community in mitigating the risk of future maritime casualties.

"This case certainly looks like humans' failed to manage their stability properly, may have decided to overload, or may have did not secure cargo properly," said **Thomas L. Bushy**, Vice President of Marine Operations, Master, T.S. Kennedy, Massachusetts Maritime Academy. "But since the investigation is in its early stages, it is too soon to place blame only on the humans."

### Human Error

In the aftermath, with a Third Mate at the helm and the reported order for passengers to stay in their cabins as the ship foundered, and with the ship's captain among the first to make it to shore safely, it would appear that the human element was indeed a contributing factor. "News reports mentioned the communications

with shore emergency agencies - and suggested they were asking for help in the decision to abandon ship: if true, this is unacceptable," said Bushy. "I am saddened that the captain and crew made bad decisions, then saved themselves before doing more to help the passengers."

"It has been proven that almost 60% of all accidents at sea are attributed to Human Error," said **Captain Jeff Cowen**, who is a graduate of the California Maritime Academy with a diverse seagoing career, working today with the State of California's Office of Spill Prevention and Response. "Fatigue has proven to be the greatest reason for human error; was the third mate rested before taking the duty of watch stander? Why wasn't the Captain on the bridge during restricted visibility? Resting perhaps?"

"Human error seems to be the catch phrase used when no other explanation is immediately forthcoming," said **Captain Ted Morley**, COO, MPT. "While it is true that it is very often the underlying cause of an accident, it is important to put it into context and determine what led to, or allowed, the human error to exist. Training, education, regulation, equipment and experience are all designed to minimize the human error factors."

### The Technology Solution

While technology in the maritime sector is arguably more capable than ever to help avoid accidents, the fact is that maritime accidents will always occur.

A current mantra in the maritime and offshore circles is "risk mitigation," and to this end it is agreed that there is no there is no technology can ever remove all risk from an maritime operations.

"Emphasis must be placed upon looking out the window," said Cowen. "What happens if the GPS, ECDIS or Radar goes out? Ships must still be able to navigate safely. At the bottom of U.S. charts there is a warning: Mariner should not to rely solely on any one means of navigation." MPT's Morely agrees.

"ECDIS, ARPA and AIS, for example have all greatly enhanced the amount of information that a watch stander has, but they have also increased the amount of time that person spends looking at all that information. A balance between technology and first person observation is needed to ensure total situational awareness."

"Technology and training are only two components though, as issues like crew size as compared to vessel size, ship's schedule, and the ability of the



As master, I can manage drills effectively, but if I do not take it to the final phase of actually giving the order to abandon ship, then I am ill-prepared. **And even when safely moored alongside my home port dock, when I give that order, it still gives me shivers!**

**Thomas L. Bushy,**  
Massachusetts Maritime Academy

**Sewol is the 100th passenger vessel lost since 2002, and there seems to be a trend to handle all of the incidents as separate and unique.** This was not the case in the tanker industry where we saw sweeping legislation and design changes after the Exxon Valdez incident. I believe we need to look at the passenger and RoRo ferry industry and evaluate every component: from the design elements of the newest super ships right down to the manning, training, and staffing of the crew.



**Capt. Ted Morley**, Unlimited Tonnage Master,  
COO, Maritime Professional Training

master and crew to act effectively are all components that need to be looked at,” Morley continued. “We are seeing an increasing amount of vessels with a decreasing pool of experienced mariners sailing on ever decreasing crew sizes. Training and technology can’t always take up the slack of smaller crews.”

**Industry Collaboration**

While it is foolhardy to expect zero accidents in the maritime sector, many

agree that emphasis on repetition in training and mixing new technology with traditional maritime skills are the ingredients to best mitigate the risk of accident.

“One of the things we stress in all of our classes here at MPT is the application of the training in real world situations. For example, we integrate our DP training with full mission simulation; this forces the student to see where that particular piece of equipment and training fits with

the big picture,” said Morley. “We also try very hard to have ‘total team training’ where we see bridge officers communicating with engineering officers, again creating an atmosphere in training that helps promote utilization of resources and sharing of information. One of the best ways to avoid human error is to simply have more people informed. Communication amongst the crew, and a willingness to work as a member of the team are vital for ensuring vessel safety.”

“It is important that new mariners remember that the new technology does not replace the skills that should be inherent to every mariner,” said Captain Ted Morley, COO, MPT. “The ability of a deck officer to navigate and plot a course is not replaced by the ability of an ECDIS unit. It is also important to teach the limitations of the technology, not just the abilities of it.” But where skills and technology ends, Morley ponders if there should be more: “The Sewol is the 100th



# HEMPAGUARD®

## EXPECT NOTHING

The new HEMPAGUARD® fouling defence system combines active hydrogel with high-performing biocide using patented ActiGuard® technology. You can expect nothing in the way of fouling for much longer than ever before – on any type of vessel and at any speed anywhere in the world.

HEMPAGUARD® gives you greater flexibility in your trading patterns, higher fuel efficiency, shorter payback time and a long-lasting return on investment. We believe that nothing compares with the HEMPAGUARD® Fouling Defence System and are offering an extensive satisfaction guarantee on HEMPAGUARD® X7 to prove it!

**Find out more at [hempaguard.hempel.com](http://hempaguard.hempel.com)**



Use biocides safely. Always read the label and product information before use.

# HEMPEL

## TRAINING & EDUCATION

passenger vessel lost since 2002, and there seems to be a trend to handle all of the incidents as separate and unique. This was not the case in the tanker industry where we saw sweeping legislation and design changes after the Exxon Valdez incident. I believe we need to look

at the passenger and RoRo ferry industry and evaluate every component, from the design elements of the newest super ships right down to the manning, training and staffing of the crew.”

Mass Maritime’s Bushy summarized the importance of repeated training per-

haps best. “What actions are practiced aboard ship to keep skill levels high to unplanned events? Drills, drill and more drills,” said Bushy. “No ship should go to sea without knowing each person aboard knows how to recognize an emergency situation, and react to notifi-

cation of one. This begins with knowing where you are aboard, how to get out, how to wear a life jacket properly, where to muster for accountability and loading of survival crafts. The officers and crew must know these skills cold, and can accomplish them in the dark with a force 8 wind howling. They must know every mistake an inexperienced crew member or passenger will make, and correct them. These skills of survival apply to all officers and crew - from the OS up to the Master. As master, I can manage drills effectively, but if I do not take it to the final phase of actually giving the order to abandon ship, then I am ill-prepared. And even when safely moored alongside my home port dock, when I give that order, it still gives me shivers.”



### Emphasis must be placed upon looking out the window.

What happens if the GPS goes out or ECDIS or Radar? Ships must still be able to navigate safely. At the bottom of U.S. charts there is a warning: Mariner should not rely solely on any one means of navigation.

**Captain Jeff Cowan** is a graduate of the California Maritime Academy with a diverse seagoing career

**GET ON BOARD WITH THE NEW INDUSTRY STANDARD IN BARGE RIGGING—  
THE YOYO WINCH.**

**THE NEW RIGGING STANDARD**



**DON'T MISS THE BOAT! YOUR EQUIPMENT MAY BE OBSOLETE.**  
The numbers are in: Patterson has set the new standard when it comes to barge rigging. Our revolutionary 25" and 40" YoYo winches have changed the way the industry works—and if you're not on board with the new technology, you'll be left behind.

**THE BIGGEST OPERATORS IN THE U.S. NOW SPECIFY PATTERSON WINCHES.**  
...and South America is joining them. With only a few exceptions, the leaders in inland shipping now use our YoYo winches—and for good reason. The YoYo eliminates fouling, springcoil, and uncontrolled spooling while saving 50% more time. It's safe, fast, and cost-effective.

**BOAT BUILDERS ARE SPECIFYING THE YOYO BECAUSE THEIR CUSTOMERS DEMAND IT.**  
True story—the YoYo is taking off not only because it's the best winch out there but because it's now specified as standard equipment by industry leaders. Patterson is expanding globally as well, which means that the rest of the world isn't far behind when it comes to demanding the YoYo.

CALL 800.322.2018 OR VISIT [WWW.PATTERSONMFG.COM](http://WWW.PATTERSONMFG.COM).  
We'll show you how the YoYo has revolutionized the industry and is setting a whole new standard.

**PATTERSON IS DEDICATED TO CREATING GEAR THAT'S SAFER, EASIER, AND FASTER. WE ARE THE FUTURE OF BARGE HANDLING EQUIPMENT, AND WE'D LIKE YOU TO SHOW YOU WHY.**  
PATTERSON | 870 RIVERSEA ROAD | PITTSBURGH, PA 15233 | [WWW.PATTERSONMFG.COM](http://WWW.PATTERSONMFG.COM)

**PATTERSON**  
SAFER. EASIER. FASTER.



**FLOSCAN**  
INSTRUMENT CO. INC.

**World Leader  
in Fuel Flow Computers**

**New Stainless Steel Flowmeters Receive  
ABS Product Design Assessment Certification**

FloScan Instrument Company, Inc. is pleased to announce that we have obtained ABS Product Design Assessment Certification for our new line of Series K Stainless Steel Diesel Fuel Flowmeters. This certification permits the installation of FloScan Fuel Monitoring Systems on ABS-classed vessels and oil rigs requiring steel piping components. See PDA Certificate Number 13-HS1050296-PDA.

Complete Fuel Monitoring Systems are available for diesel engines rated from 25 to 6000 HP and are priced up to 50% less than the competition.  
Call 206-524-6625 ext 316 or e-mail [joe@floscan.com](mailto:joe@floscan.com) for more info.



FloScan Instrument Co., Inc. | Seattle, WA USA  
206-524-6625 | e-mail [sales@floscan.com](mailto:sales@floscan.com) for quotes

[www.floscan.com](http://www.floscan.com)



## SAAB R5 SOLID AIS CLASS A SYSTEM

The R5 SOLID AIS System is a powerful and compact single box solution based upon advanced Software Defined Radio (SDR) technology. The R5 SOLID AIS System is a future-proof product which offers a quick and easy installation ideally suited for SOLAS, inland waterways, commercial fishing vessels as well as the Yachting industry.

For years, maritime operators have trusted Saab and Saab AIS technology. Our highly versatile R5 concept is formed by the *thinking edge* of innovation and experience and it will continue to evolve as new requirements are introduced, keeping you at the forefront of AIS technology for many years to come. In co-operation with our partners the R5 systems are available for sales and service worldwide.

Contact us today.

[www.saabgroup.com/transpondertech](http://www.saabgroup.com/transpondertech)



VGP CHANGES ARE COMING.  
AND WE'RE READY FOR IT.



RSC Bio Solutions offers a full line of highly capable, readily biodegradable\* hydraulic fluids and cleaners that are a perfect blend of safety and performance. That means non-sheening, low aquatic toxicity products that can lead to a reduction in project delays and downtime. And it certainly means complying with the 2013 Vessel General Permit (VGP). Because you've already got enough to worry about out there.



Products you need  
for problems you don't.™

EnviroLogic is a registered trademark of Terresolve Technologies, Ltd.  
SAFECARE is a registered trademark of Gemtek Products, LLC.  
Terresolve Technologies Ltd. DBA RSC Bio Solutions.



Find out more at [rscbio.com](http://rscbio.com)  
or call 800-661-3558.

\*ASTM 5864 and ASTM D7373 compliant.

13807316

# Does e-Learning Work?

It's time to put that question behind us.

Once a question has been carefully analyzed and a reliable answer has been found, it is time to use this new knowledge to help answer the next series of important questions. This is the current situation in some parts of the maritime industry surrounding the question of whether eLearning works.

To illustrate, some months ago there was a familiar discussion on an online maritime group debating whether eLearning works. Arguments on both sides cited anecdotes and conjecture on topics for which we already have solid answers informed by real research. This highlights the need to broadly disseminate what is already known about this question. Therefore, this article provides some of the most compelling evidence on the question of whether eLearning works in the maritime industry. This knowledge can then be used to contribute to the discussion of other pressing, yet unanswered, maritime training questions such as how to cross cultural and language barriers in training, how to raise the standards of all maritime training without increasing costs, and how to support a culture of safety through attention to training.

## The Quick Answer

We will cover the evidence in a moment, but first let me clearly state the answer to the question, "Does eLearning work"? The answer is an unequivocal "YES". But as with any complex topic, there are many parts to that answer. So here are a few quick, but very important, considerations.

## Not All eLearning Experiences are Equal

Neither are all classroom experiences. There are excellent and poor examples of both online and classroom-based training. We don't abandon the classroom just because we had a terrible instructor once. Likewise, we should not abandon eLearning just because we have encountered poor implementations (of which there are many). So when consid-



ering the question of whether eLearning works, we are comparing offerings of roughly equal quality.

## The Difference Between Knowledge & Skills

Maritime industry workers require both knowledge and skills to do their jobs safely and efficiently. It is important to realize that effective training techniques for knowledge are not the same as those for skills. Having said that, keep in mind that all skills are built on a foundation of knowledge. Therefore even if you believe you are only teaching a skill, there is always a strong knowledge component to that training. So both must always be considered.

## Blended is Best for Knowledge

The evidence will be presented below, but here is the quick fact. All else being equal, when comparing online learning with classroom-based learning, they come out roughly equal for teaching knowledge, with eLearning offering a slight advantage. Yes, this is surprising,

but it is a fact. More importantly, if you combine online and face-to-face training (a technique called "blended learning"), you get significantly better training outcomes than by employing either online or face-to-face training alone. This is very important as it gives us an opportunity to make real training improvements that were simply not available to us 10 years ago.

## No Replacement for Hands On Training

This is one of the most common arguments I hear against online learning. I believe that the statement is completely true, but it is in no way an argument against on-line learning. Hands-on training for skills provides the context, experience, environment and tactile feedback that a simulation will approach, but never fully match. However, simulations will provide variety in, and control of, the training scenario that hands-on training can never match. Each approach offers something the other one does not. Therefore in this case we can use mul-

multiple, complementary training approaches to yield excellent results - better than either one approach can produce alone.

## Technology Offers Unique Benefits

In addition to improving training outcomes, adding a technology component to your training yields benefits not available otherwise.

For example, eLearning systems are excellent providers of deep learning metrics and analytics. This is real-time data about how well your trainees are performing and where the gaps are. This allows you to continuously improve training at your organization and close gaps in training outcomes before they become safety or performance issues.

Another example is how technology can bring training to the trainee. This has the effect of improving access to training, bringing it to those who might not otherwise have the opportunity.

Technology also supports more flexible training delivery models. A very common and highly effective approach is to have trainees pre-train using eL-



earning, and then converge afterward at a central location for a shorter and more effective face-to-face experience.

These are some of the quick facts. Let's look at the hard evidence now.

### The Evidence

Arguably the best evidence of eLearning effectiveness is a report published in 2010 by the U.S. Department of Education (U.S. DOE). The report is entitled "Evaluation of Evidence-Based Practices in Online Learning, A Meta-Analysis and Review of Online Learning Studies". The strength of this report comes from the fact that it is a meta-analysis. A meta-analysis looks at a large number of independent studies and draws a conclusion based on the strength of this large collection. This is powerful because the biases or flaws of individual studies are quickly filtered out of the collective response.

In the case of the U.S. DOE study, the meta-analysis looked at roughly 1,000 research studies, and then filtered them down to 45 which met rigorous design standards. From these studies the analysis came to several conclusions. Let's look at some of the most notable quotes from this study:

### Conclusion Number 1

#### Online Learning Outperforms Face-to-Face Learning:

*U.S. DOE Quote:* "Students in online conditions performed modestly better, on average, than those learning the same material through traditional face-to-face instruction. Learning outcomes for students who engaged in online learning exceeded those of students receiving face-to-face instruction."

The difference in effectiveness measured between online and face-to-face instruction was quite small, but it exists with the win going to online learning. From this we can say unequivocally that online learning most certainly does not produce inferior outcomes when compared to face-to-face instruction, as many incorrectly believe. In fairness, however, until I performed my own studies on eLearning effectiveness as a university researcher in the 1990s, I also assumed that eLearning would be inferior. I was wrong.

### Conclusion Number 2

#### Blended Learning is Best:

*U.S. DOE Quote:* "Instruction combining online and face-to-face elements had a larger advantage relative to purely

*face-to-face instruction than did purely online instruction."*

The conclusion above indicates that when you use a combination of on-line and face-to-face training (referred to as "blended learning"), the learning outcomes are better than for either face-to-face or eLearning alone. This makes intuitive sense because each mode of learning has strengths the other one cannot offer. The implications are clear. If your goal is to provide the very best training possible, you should use a combined approach involving both face-to-face training and online learning.

### Conclusion Number 3

#### Interaction with Peers and/or Instructors Improves Learning Outcomes:

*U.S. DOE Quote:* "Effect sizes [i.e. the improvement in learning outcomes] were larger for studies in which the on-line instruction was collaborative or instructor-directed than in those studies where online learners worked independently."

This is a very important conclusion which cannot be stressed enough. One of the major advantages of online learning is its ability to connect people to one another, allowing them to learn from one another in a way that face-to-face training can't. While it is indeed possible and effective for trainees to learn online independently, the best outcomes are achieved when we use technology to connect people to further facilitate the learning process.

### Conclusion Number 4:

#### eLearning Works, Regardless of the Subject Matter:

*U.S. DOE Quote:* "The effectiveness of online learning approaches appears quite broad across different content and learner types."

eLearning has been around long enough and studied long enough that we can safely conclude that it is effective for all kinds of knowledge acquisition. There is nothing about maritime knowledge or maritime learners that makes the field immune to the benefits of eLearning. That is not to say that there are no hurdles to overcome in maritime eLearning - there are. For example, the availability of internet on-board, and the sophistication of vessel-based training both have slowed the adoption of eLearning in the industry. However, those obstacles are being (and have been) largely overcome by maritime-specific learning manage-

ment systems (LMSs) and the industry is following suit by adopting eLearning methods. This study makes it clear that the benefits of eLearning are not domain-specific.

eLearning works. It has strengths which create an opportunity to do better than we do now. It is not a replacement for face to face or hands-on training, that is the wrong discussion to be having because we already know the answer. The real discussion is about how we apply the strengths and advantages that eLearning brings to an industry that is in desperate need of better (not more) training, more uniform training, and an elevated discussion on what we can do to achieve these.

## The Author

Pek Murray Goldberg is CEO of Marine Learning Systems ([www.MarineLS.com](http://www.MarineLS.com)). An eLearning researcher and developer, his software has been used by 14 million people worldwide.

Over **300 times**,  
over **500 organizations**,  
in **25 countries**

...over **4000 professionals**  
needed to know.



*If you're in the  
marine industry,  
you need  
to know too!*

### Sign Up Now for Our 2014 Essential Maritime Management Training Programs

#### Contract Management for Ship Construction, Repair & Design

|             |                  |
|-------------|------------------|
| Seattle, WA | May 20-22, 2014  |
| Halifax, NS | Sept. 9-11, 2014 |

#### The Port Engineer's and Owner's Representative Course

|                 |                  |
|-----------------|------------------|
| New Orleans, LA | June 17-19, 2014 |
| Tampa, FL       | Oct. 28-30, 2014 |

For more information:  
[www.shipcontractmanagement.com](http://www.shipcontractmanagement.com)

For more information:  
[www.shipportengineer.com](http://www.shipportengineer.com)



Consulting Naval Architects and  
Marine Engineers, Project Managers

147 Columbia Turnpike, Suite 203  
Florham Park, NJ 07932 USA

In-house programs are also available. They are particularly cost effective for groups of 10 to 25. Please call to discuss.

Register online or contact us at:  
[register@fishermaritime.com](mailto:register@fishermaritime.com)  
1-800-732-3476 (US/CAN)

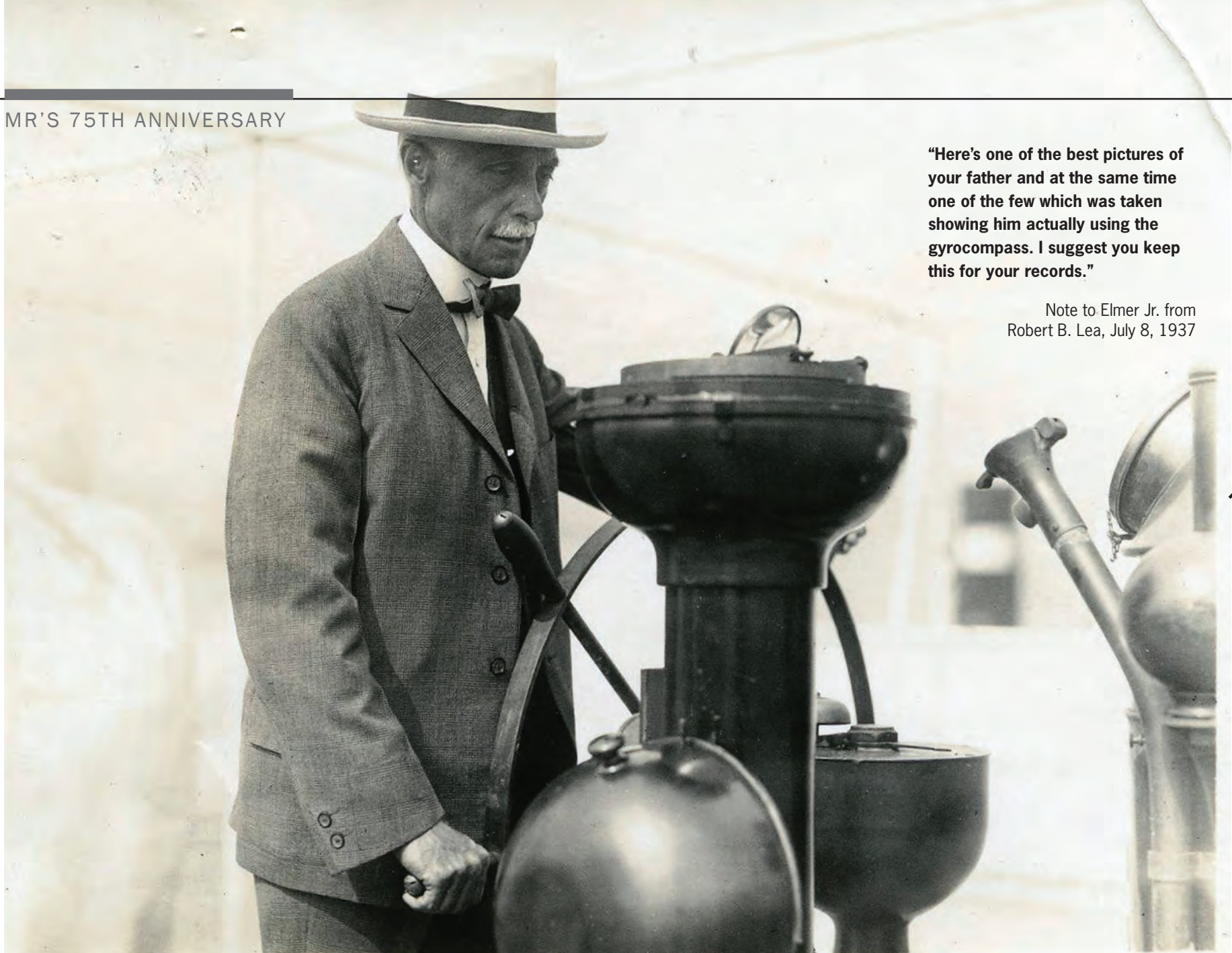

**"Here's one of the best pictures of your father and at the same time one of the few which was taken showing him actually using the gyrocompass. I suggest you keep this for your records."**

Note to Elmer Jr. from Robert B. Lea, July 8, 1937

(Photo: Hagley Museum and Library)

## *Inventor, Entrepreneur, Industrialist &* **The Father of Modern Navigational Tech**

*By Patricia Keefe*

**E**lmer A. Sperry casts a long shadow over the history of modern naval, nautical and aeronautical technology, one few people know much about, but should, for a man crowned both the "father of modern navigational technology" and "the father of automatic feedback and control systems," as well as a pioneer of rocket and missile technology.

"It is safe to say that no one American has contributed so much to our naval technical progress," eulogized Charles

Francis Adams III, Secretary of the Navy from 1929-1933, on the death of engineering genius Elmer Ambrose Sperry, June 16, 1930, at 69.

Appointed to a newly formed Naval Consulting Board in 1915, Sperry spent the next decade working closely with the Navy, at times alongside his aviator son Lawrence (see related story, p. 38), developing gyro-compasses, stabilizers, autopilots, bomb sights, automatic fire control systems and powerful spotlights for ships and aircraft. Much of this technology was deployed by the Navy in both world wars, and continues to be

used in some form on vessels of all sizes today.

### **"Harnessing the motion of the earth"**

Describing Sperry as "... he who harnessed the motion of the earth to do his bidding. . . , the *New York Times* in an editorial on the day after his death, celebrated his achievements thusly:

"For those who travel by sea he provided not only the pilot who whatever betides hold his rudder true, but also a 'stabilizer' to prevent the rolling of the ship and a device for signaling to prevent collisions. For those traveling by air, he

has helped to maintain the equilibrium of their planes and to lessen the peril of fire and to penetrate the fog."

Sperry's inventions, which often involved electricity and employed some form of control system, contributed greatly to advancements in lighting, mining, rail safety, street cars, brakes, engines, automatic ignition, automatic pilots, radar, guided missiles, drones and wireless systems. But if anyone deserves the epitaph "steady as she goes," Sperry does.

The *New York Times* had it right when IT described Sperry as "... ever thinking

ENGINEERED  
COOLING SOLUTIONS.

Over 65 Years Cooling  
The Marine Industry

fernstrum.com 906.863.5553  
**FERNSTRUM**  
R.W. Fernstrum & Company

GRIDCOOLER  
Kinet Cooler

WEKA  
Boxcooler

Tranter  
Heat Exchangers



**VULKAN  
COUPLINGS**

Photo credit: LCS2

Your source for premium power transmission solutions for Marine, Industrial and Construction Equipment applications in North America (including Canada and Mexico), the Caribbean and now countries of Central America and parts of South America including the nations of Columbia, Ecuador, Peru and Venezuela.

**American VULKAN Corporation**  
Ph: 863-324-2424 | info@vulkanusa.com | www.vulkan.com

---

# Elmer A. Sperry

“The marine interests may certainly expect great and material aid from this wonderful instrument. **Not only, I predict, will it guide our ships** but it will be found to have other important and far-reaching bearing upon the operation of ships at sea.”

Elmer A. Sperry, in prescient comments on Hermann Anschütz-Kaempfe's gyrocompass, at a meeting of SNAME in 1908.

of how he might make the dwellers on earth a little more at ease whether on sea or land or in the air.” In fact, his inventions, which typically focused on motion and energy, were all about creating, controlling, driving or directing movement. If it moved – whether it needed to be stabilized, navigated or powered, Sperry was on it. He even produced some of the earliest versions of electric cars, drones and remote controls – technologies that we are only beginning to scratch the surface of today he was experimenting with in the early 1900s.

Sperry even teamed up with physicist

A. A. Michelson in 1922 to develop instrumentation to measure the speed of light. The value of the speed of light accepted by many today (299,792.5 km/sec) varies only 2.5 km/sec from that obtained using the Sperry octagonal steel mirror.

Many consider his contributions to inertial navigation to be the most important. Inertial navigation combines a computer, motion sensors and rotation sensors (gyroscopes) to continuously calculate via dead reckoning the position, orientation and velocity of a moving object without the need for external references. These

systems are used in a range of applications, from transportation, i.e. submarines, ships, cars and planes, to guided missiles and spaceships.

“Inertial systems can sense direction and speed, and by inertia tell where the ship is going. It’s a perfect dead reckoning machine,” said Craig Dalton, a professor of marine transportation at Massachusetts Maritime Academy.

Sperry’s ideas were often years, even decades ahead of his time. For example, his early work with autopilot for ships and planes is seen by some as predating the start of contemporary cybernetics –

the scientific study of control and communication – pegged to the mid- to late 1940s by most accounts.

And while the U.S. Navy declined to pursue these avenues fully during the First World War, the “Sperry air bomb” and other efforts to control torpedo trajectory place Sperry among the earliest developers of drones and wireless control systems.

#### **Inventor Rivald Edison**

A virtual nonstop inventing machine, Sperry collected or had pending close to 380 patents, twice as many as Thomas



The dog with pipe and hat was used in an advertisement for Sperry Gyroscope Company circa 1927.

Edison at the time of his death (and Edison went on to hold the record for most patents granted to an American). Sperry was also a prolific entrepreneur, founding eight companies along the way.

Sperry was a man of his age – an era when the inventor-entrepreneur first came into play. Some, like Edison and Henry Ford, created whole new industries and manufacturing empires with their inventions. Others, like Sperry, while certainly interested in profit and successful financially, were drawn more to the science involved and the opportunity to apply new technologies and mechanics, according to his biographer, Prof. Thomas Hughes Park, author of the highly referenced *Elmer Sperry – Inventor and Engineer*. He was forced to sell off his first company, the Sperry Electric Light, Motor, and Car Brake Co., which he founded in 1880 at the age of 20, five years after its founding. The experience proved a lesson to Sperry. He wasn't interested in being at the beck and call of other people's assignments, or as much in the business of running a company, as he was in having the opportunity to explore new technologies and innovate, and the chance to tackle problems of his choosing. All of which led him to launch one of the country's first research laboratories in 1888.

What Sperry is known most for is the gyroscope and its application to many problems, most notably in his version of the gyrocompass, but that's just the tip of the iceberg of the man's inventions and interests.

He was among a handful of inventors toying with electric cars in the late 1800s, winning patents for combustion engines (later adapted to aircraft engines), automatic transmissions and electric brakes, street cars and automobiles, as contemporaries in England and Germany produced vehicles for sale, and electric cab companies buzzed onto the scene on both sides of the Atlantic. But the concept was doomed, both by the unreliability of rechargeable electric

(Photo: Hagley Museum and Library)

**TRANSAS**

**ECDIS is not enough for me.**  
 ECDIS alone isn't enough to be compliant; official charts and training are mandatory too. I work with a company that has it all. Transas has spent over 20 years refining the world's best ECDIS solutions. Find all the answers at [ECDISfit.com](http://ECDISfit.com)

Transas Marine.  
 The world's number one in ECDIS

ECDIS • CHARTS • TRAINING • SUPPORT • INTEGRATION • CUSTOMER SERVICE • SOFTWARE

**HEMPAGUARD®**

**First industry satisfaction guarantee on hull coatings**

Find out more at [hempaguard.hempel.com](http://hempaguard.hempel.com)

**HEMPEL**

NEW ActiGuard Technology

**Kidde Marine**

**FIRE SUPPRESSION SYSTEMS**

Since 1917

[WWW.KIDDEMARINE.COM](http://WWW.KIDDEMARINE.COM)

**ECS CLEAN AGENT SYSTEMS**

- Safe for Occupants
- Rapid Extinguishment
- Minimal Damage
- Electrically Non-conductive
- Minimized Vessel Downtime
- Environmentally Responsible
- Globally Accepted & Supported

**CARBON DIOXIDE SYSTEMS**

- Superior Suppression
- Time-tested

**WHDR GALLEY PROTECTION**

- Rapid Extinguishment
- Proven Performance

batteries and the mass production of gas-powered cars at half the cost of electric.

That state of affairs would prove fortuitous for other modes of transportation – notably ships and planes, the latter another emerging – and more successful – technology in the late 1800s to early 1900s.

Sperry's early interest in electricity – which he dropped out of Cornell after a year to pursue – was eventually overtaken by his fascination with gyroscopes

and gyrocompasses. He neither discovered these concepts, nor was he the first to market with patents. That was German Hermann Anschütz-Kaempfe, who was awarded a gyrocompass patent in 1906 in the U.K.

Sperry could barely contain his enthusiasm at a 1908 meeting of the Society of Naval Architects and Marine Engineers (SNAME), telling the gathering, "The marine interests may certainly expect great and material aid from this wonder-

ful instrument. Not only, I predict, will it guide our ships, but it will be found to have other important and far-reaching bearing upon the operation of ships at sea."

Sperry's approach in general was to expand upon and further advance existing applications, which he particularly applied to gyroscopes. For example, by 1907, Sperry was working on the issue of stability in moving vehicles. He took gyro-stabilizer technology already in ex-

istence – it fostered stability by pushing rolling ships in the opposite direction of the force of the waves – and added a motion sensor, a motor to amplify the effect of the sensor on the gyroscope and an automatic feedback and control system. The net result was a better performing stabilizer. He followed that up with his improvements on existing gyrocompass technology.

His timing was perfect.

The gyrocompass was immune from

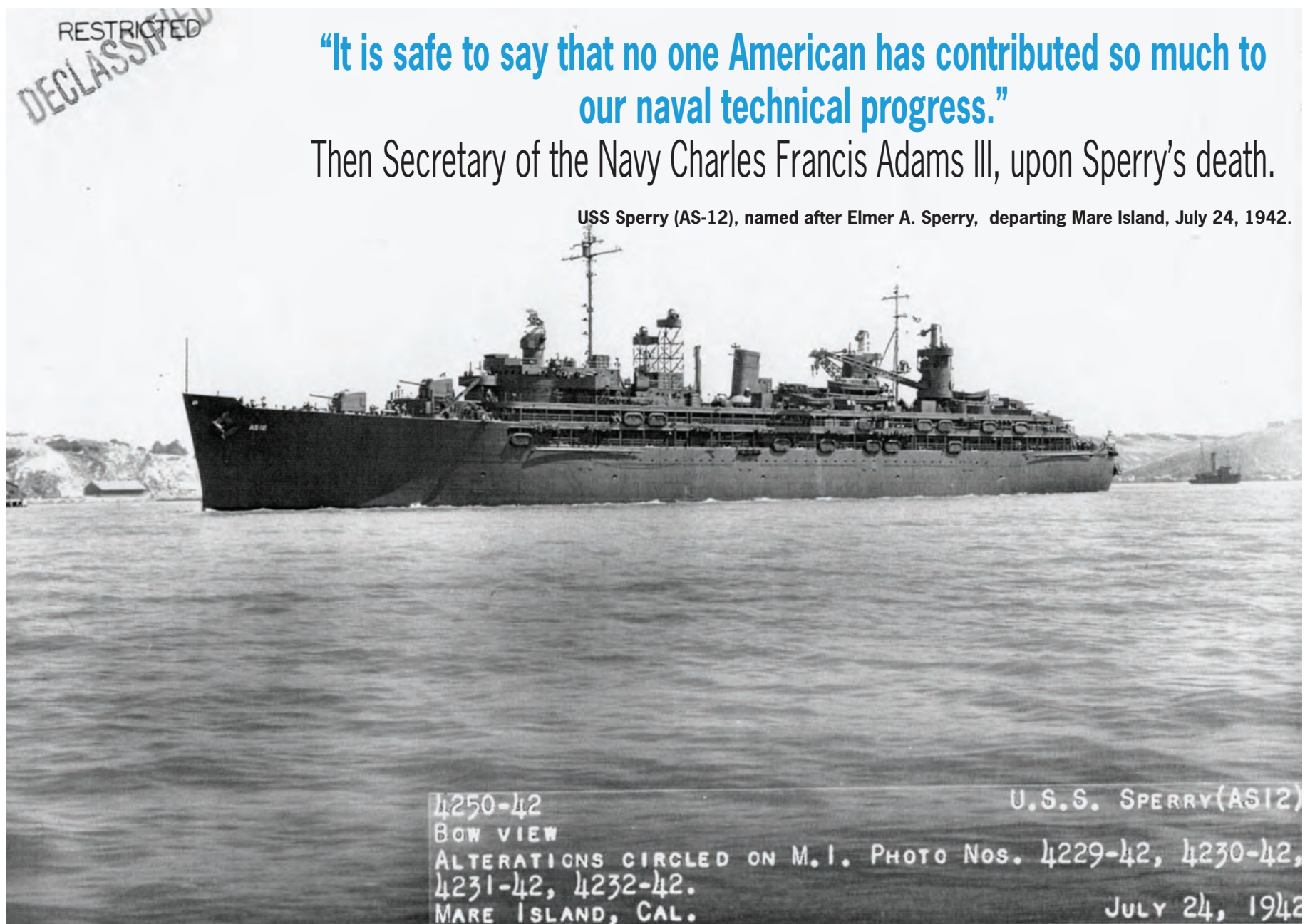

**"It is safe to say that no one American has contributed so much to our naval technical progress."**

Then Secretary of the Navy Charles Francis Adams III, upon Sperry's death.

USS Sperry (AS-12), named after Elmer A. Sperry, departing Mare Island, July 24, 1942.

# Sperry's Patents

Elmer A. Sperry was a man of wide ranging interests and ideas, delving into areas ranging from electricity to navigation, to automation to motion control and missile guidance, to even the more mundane, such as his golf bag support (patent #1,686,774) – to name a few. Along the way, he founded at least eight companies and two technical societies, served on countless boards and industry and technical associations, and collected an estimated 380 or so patents. What follows is a sampling of Sperry patents that have enhanced and influence maritime technology over the last century or so:

## NAVIGATION:

Ship Gyroscope (Filed 1908), Ship Gyrocompass (Filed 1909), Gyroscopic Navigation Apparatus, Navigational Apparatus, Navigational Instruments, Repeater System For Gyrocompasses, Electric Drive For Gyroscopes, Controlling Mechanism For Ships Gyroscopes, Gyroscopic Pendulum, Control Gyro

## STABILIZATION:

Gyroscopic Apparatus For Determining Periodic Motion, Gyroscopic Stabilizer, Stabilizing Gyroscopes, Multiple Gyro Ship Stabilizer, Ship Stabilizing And Rolling Apparatus, Gyroscopic Roll And Pitch Recorder, Means For Preventing The Pitching Of Ships

## DEFENSIVE:

Various Patents For Detecting, Tracing, Locating And Signaling Submarine Boats, Anti-Aircraft Systems

## AIRPLANES:

Speed And Direction Indicator, Aeroplane Stabilizer, Position Indicator, Automatic Pilot, Automatic Sighting Mechanism For Aircraft Guns, Gyroscopic Inclinometer, Beacon System For Night Flying, Automatic Steering For Dirigibles, Variable Pitch Propeller, Automatic Launching Device For Airplanes (127)

## WEAPONS:

Driving And Governing Means For Torpedoes, Electrical And Gyroscopic Apparatus For Torpedoes, Automatic Gun Pointing, Multiple Turret Target Indicator, System Of Gunfire Control, Submarine Mine, Wireless Controlled Aerial Torpedo, Gravity Bomb, Wakeless Torpedo, Bomb Site, Fire Control System. Method Of Gunfire Control For Battleships, Automatic Accelerator, Automatic Steering (1926)

## OTHER PATENTS OF NOTE:

Multiple Patents For Power Gearing And Controllers For Electric Cars (Filed 1984-1896), Electric Vehicle – (Filed 1898), Wireless Control System, Electrical Arc Light, Signaling System For Warships, and engines of all kinds.

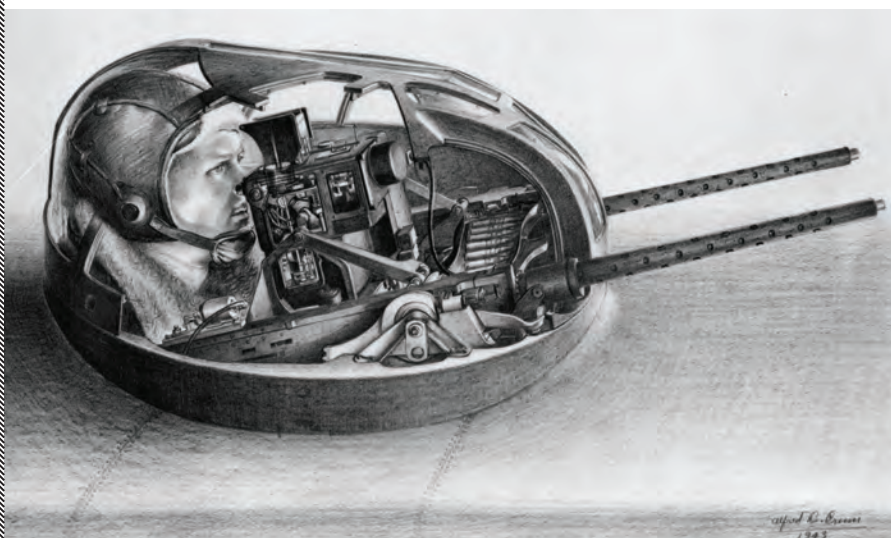

**Left:** Sketch of gunner in Sperry airplane upper machine gun turret, 1943.

(Photo: Hagley Museum and Library)

**Bottom Left:** Manual detail of Mark XIV gyrocompass, removed from binnacle.

(Credit: San Francisco Maritime National Park Association)

**Below:** Predecessor of the modern Drones? Pilotless plane controlled by Sperry gyroscopes, a pilotless Curtiss B-2 flies over Sacramento, Calif., in May 1930.

(Credit: National Archives)

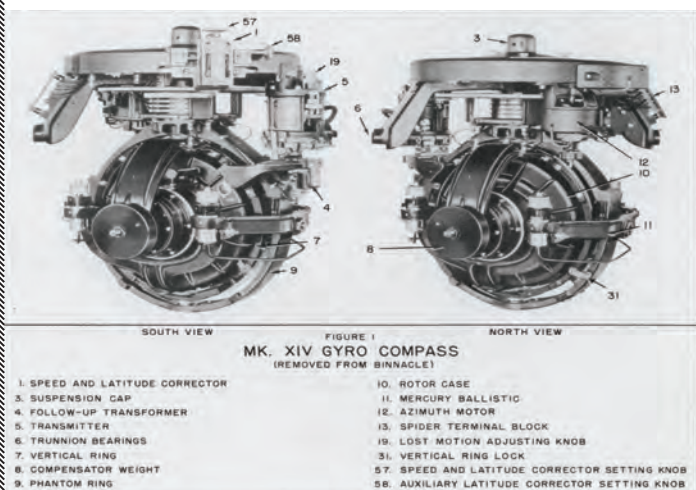

deviation and variation problems, which had been difficult to overcome, particularly in the huge steel warships that the Navy was starting to turn out. According to Sperry Marine's corporate history, three things drove the transformation of the gyroscope from a curiosity to a usable technology. "These were the increasing use of steel in ships which then brought about the second need: to overcome the unreliability of the magnetic compass within a steel ship, and finally, the great powers were preparing to conduct underwater warfare – in steel hull ships." A fourth variable was also key – an electronically driven gyroscope invented by G.M. Hopkins would enable the gyroscope to act as a reliable reference device in those steel ships.

## Gyroscopes and Gyrocompasses

As described by MIT, a gyroscope is a disk mounted on a base in such a way that the disk can spin freely on its X- and Y-axes; that is, the disk will remain in a fixed position in whatever directions the base is moved." A gyroscope will always point to a fixed point in space if left undisturbed. If force is exerted upon it, it will react at right angles to the force applied. This characteristic combined with other elements of precession, pendulosity and damping will allow the gyro to settle toward true north.

A gyrocompass incorporates a gyroscope and is a non-magnetic compass that uses a fast-spinning disc and the rotation of the Earth to automatically find geographical direction, or true north.

"A gyroscope is for stability purposes; a gyrocompass is purely for navigation," said Dr. Josh Smith, a professor at Kings Point. "The original gyrocompass stood four feet tall at several 100 pounds and was used by the mate in charge of the watch. Now it can fit in the palm of your hand.

At the same time Anschutz-Kaempfe, who was seeking a reliable form of navigation for a submarine expedition to the Arctic Pole, was patenting the first north-seeking gyrocompass, Sperry in 1908 received a patent for his version of the gyroscope. Sperry filed a patent the first ballistic gyrocompass 1911 (which he received in 1918 in the U.S.) and set about with his son Lawrence, trying to sell it to the U.S. Navy and others abroad.

Initial disinterest by the U.S. military led Sperry to successfully pitch his technology to Japan and Russia. Even-



tually the U.S. Navy came around and adopted his compasses and stabilizers in 1911 after successful trials on the USS Delaware and USS Drayton - as did the French, British and Italian Navies.

The Navy also began using Sperry's gyroscope-guided autopilot steering system, variously called a "Metal" or "Iron" Mike.

"It was a big manpower saver because you didn't need a helmsman," said Dalton. "I had captains when I sailed who did not want seamen on the wheel because the autopilot used less fuel. Many captains believed the autopilot steered better than men."

The Drayton trial produced the repeater compass and the target-bearing pointer. This was followed by a request from the Navy to examine the fire control problems faced by ships bearing long range guns.

Ship gun fire-control systems (GFCS) enable remote and automatic targeting of guns, with or without the aid of radar or optical sighting. Sperry developed the first full gun battery fire control systems, which were placed aboard every U.S. battleship during World War I.

Before the advent of the fire control systems, if a gunner aimed a gun and the boat pitched, his gun would end up pointing in the water. But Sperry gave the gun mounts turrets that prevent the ship's pitch from interfering with the trajectory of the gun.

Sperry also provided the Navy with a 5-ton device called a gyro stabilizer, designed to keep ships from rolling. The Navy installed it on the USS Worden, and another one on a submarine. The onset of WWI put further orders on hold.

In 1910, Sperry started the Sperry Gyroscope Company in Brooklyn to sell his inventions, locating near the port of New York so ship captains could easily visit his factory.

Among the projects the company worked on during World War I was an autopilot for airplanes, gunfire control systems, machine guns that could easily track their targets, bomb sights and

gyroscopically-guided aerial torpedoes. Like so many of his earlier inventions, these often relied on automatic control and feedback systems. In 1918, he produced a high-intensity arc lamp that had an unheard of brilliance equal to that of a billion candles. It was used as a searchlight by both the Army and Navy, and helped to fend off German air raids on London and Paris.

In the midst of all that activity Naval Secretary Josephus Daniels launched the Naval Consulting Board in 1915 with the help of Thomas Edison to put the brightest minds of technology and science to work for the war effort. Sperry was tapped as part of the inaugural crew and went on to lead several committees, and eventually held the chairmanship. It was there he and his son Lawrence teamed up with Peter Hewitt to develop the Hewitt-Sperry Automatic Airplane, a so-called "flying bomb" and one of the first successful precursors of unmanned aerial vehicles, or as they are called today, drones. It is considered by some to be a precursor of the cruise missile.

"Torpedos never were especially accurate. A gyroscope helped keep them running straight and true," according to Kings Point's Smith.

Also in 1915, Anschütz-Kaempfe slapped Sperry with a patent lawsuit over his gyroscope technology after Sperry attempted to sell his gyroscope to the German Navy. Anschütz-Kaempfe retained as an expert witness, a young Swiss patent office employee named Albert Einstein. In a trial that dragged out over two years, Einstein shredded Sperry's defense, and Anschütz-Kaempfe won the lawsuit in Germany. Sperry, however, prevailed with his patent in the U.S. and the U.K.

After the war, one of Sperry's last accomplishments came in September 1929, when Sperry engineers working with the U.S. Army Air Corps, developed and successfully tested two new capabilities - the artificial horizon and the aircraft directional gyro - recording the first all-blind flight in history. The technol-

ogy was quickly adopted by commercial airlines and installed aboard mail planes.

### An Iron Legacy

The reach and enormity of Sperry's contribution to naval science, offensive weaponry and the navigation and control of transports on water and in the air, cannot be overstated. It stretches well beyond his lifetime and is still working to aid sailors, pilots and the military around the globe.

Sperry, once a member of countless technical and scientific societies, was the recipient of numerous awards and honors.

In 1941 the Navy christened the USS Sperry (AS-12) in his honor, while the Post Office introduced an airmail stamp in recognition of the contributions of both father and son to flight.

Today, there are a number of awards given out in his name, including one

from Northrup Grumman given to a U.S. Naval Academy midshipman every year, one from Honeywell and the Elmer A. Sperry Award for "advancing the art of transportation engineering," given out by a consortium of societies he once belong to.

According to Sperry biographer Hughes, among the many upon whom the inventor made a great impression was Helen Keller, no stranger to fame and admiration herself.

Sperry went out of his way to "show" her how the gyroscope worked, the movement of the compass and the brightness of the arc lights.

A "wonder-filled" Keller summed it up best when she said she thought Sperry would be remembered for a compass and a star for "if there were no other immortality, you would live forever in that achievement."

*And so he will.*

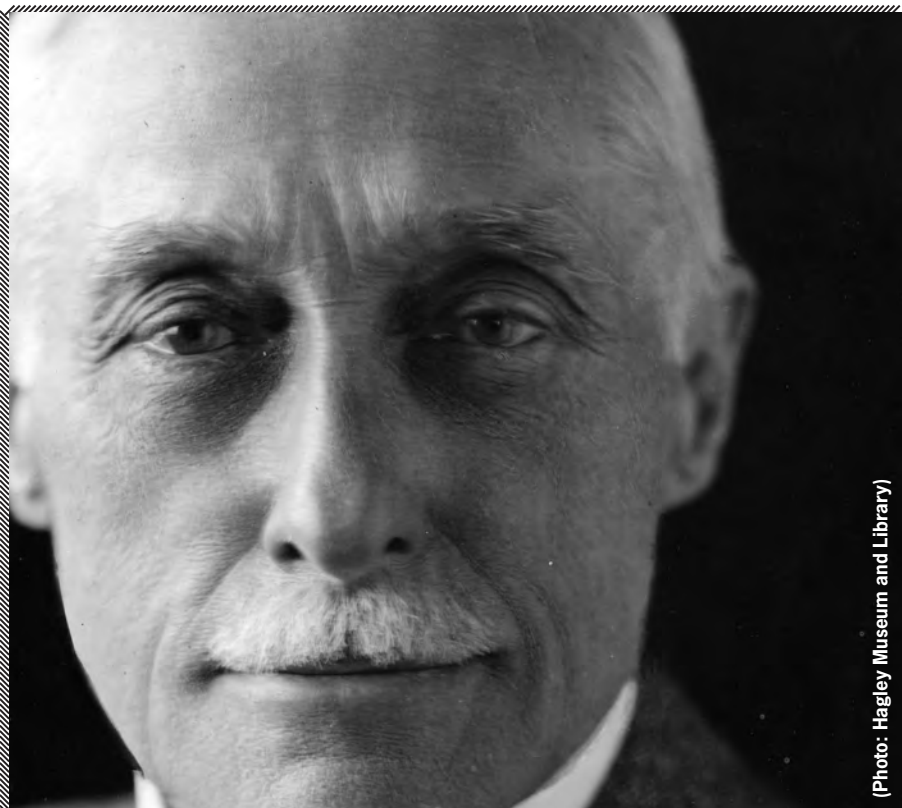

Photo: Hagley Museum and Library

## Sperry's Companies

Inventor-entrepreneur Elmer A. Sperry was fond of launching new companies to manufacture new inventions and support his wide ranging interests, at times folding, morphing or selling off older companies even as he was forming new ones. He is perhaps most closely associated with the Sperry Gyroscope Co.:

- Sperry Electric Light, Motor, and Car Brake Co., founded at the age of 20 to manufacture Sperry's electric dynamos and arc lamp invention. (1880)
- Sperry Electric Mining Machine Co. (1888)
- The Elmer A. Sperry Co., for research and development work (1888)
- Sperry Streetcar and Electric Railway Co., for electric streetcars and their components (1894)
- Chicago Fuse Wire Co., (1900); and separately established an electro chemical laboratory in Washington, DC., where he discovered a process for recovering tin from scrap metal.
- Sperry Gyroscope Co. (1910), founded to manufacture navigation equipment, chiefly his own inventions – the marine gyrostabilizer and the gyrocompass. During World War I the company diversified into aircraft components, such as bomb sights, fire control systems, airplane stabilizers and autopilot.
- Sperry Development Co. (1926), Sperry Products Inc. and Sperry Rail Service - all associated with his rail detector and diesel engine products.

The Sperry companies that remained, including the Lawrence Sperry Aircraft Co., eventually became the Sperry Corp. several years after the deaths of both Elmer Sperry and his son Lawrence, with the maritime sector spinning off into Sperry Marine in 1997, which eventually became part of Northrup Grumman Corp., a worldwide supplier of navigation, communication, information and automation systems for commercial marine and naval markets.

Also a member of many engineering, aeronautical, maritime, industry and other scientifically-oriented organizations, Sperry founded at least two:

- Founder and charter member of the American Institute of Electrical Engineers
- Founder and charter member of the American Electro-Chemical Society

He was also an inaugural member and eventual chairman of the U.S. Naval Consulting Board, which was formed in 1915 by the Secretary of the Navy with help from Thomas Edison.

## Aviator & Engineer

# Lawrence Burst Sperry

*A chip off the old block makes aeronautics his claim to fame*

*By Patricia Keefe*

The U.S. Navy, and the aeronautic field in general, has benefited enormously from the genius of more than one Sperry. Lawrence Burst Sperry, the second son and third child of gyrocompass inventor Elmer A. Sperry was a pioneer in instrumental flight and famous inventor in his own right, launching the Lawrence Sperry Aircraft Co. at 26, and earning 23 patents before his untimely death at the age of 31 in 1923. Aviation promoter and Air Service General Billy Mitchell lauded him as one of the most brilliant minds and greatest developers in the world of aviation, while one newspaper called him “Uncle Sam’s youngest technical expert and aviator.”

It was no exaggeration.

Like his father before him, Sperry’s engineering brilliance more than made up for his lack of a college degree, and he too achieved acclaim in his early 20s as an innovator and inventor, primarily in aviation.

The youngest licensed pilot in the country, Lawrence first gained fame as the inventor of the autopilot, a small gyroscopic stabilizer for planes that controlled the three axes of flight — yaw, pitch and roll — to maintain course and altitude.

Most ships today still use a Sperry-type stabilizer to dampen rolling, along with some version of a Sperry autopilot linked to a Sperry gyrocompass.

He also invented the artificial horizon; a turn and bank indicator; the first amphibious flying boat; an airspeed indicator, a drift indicator, a signifi-

cant improvement over the liquid-filled magnetic compass and a parachute pack — inventions that formed the basic instruments of all manner of planes and most of which remain in use today.

A font of ideas, Sperry also tackled night flying issues and built the first wheeled retractable landing gear in an amphibian. That got him a splash in the March 29, 1915 *The Aerial Age Weekly*.

But it was his performance at French air competition for plane safety in 1914 that turned him into an international star overnight and netted a \$10,000 prize. With his parent looking on, the 22-year-old Sperry and his mechanic wowed the crowd, which included military observers, by walking out on the wings of the plane while it was aloft, to demonstrate his autopilot technology. Sperry, with his hands up in the air, offered a whole new take on “Look Ma, no hands!,” to an incredulous crowd.

By 1916, Lawrence was a commissioned junior lieutenant in the U.S. Navy and assigned as a flight instructor. A brief stint on active duty in 1918 was cut short by emergency surgery, enabling him to continue his focus on innovation. He was the first civilian to join the Navy Flying Corps Reserve in 1917.

Working with his father, Elmer A., the two developed one of the earliest drones — an unpowered aircraft that could fly to a target guided, once again, by Sperry Sr.’s gyroscopic device. Despite some initial interest and funding from the Navy, however, uneven test results and trips back to the drawing board led the





(Credit: Library of Congress)



(Photo: Hagley Museum and Library)

**Lawrence Sperry lands plane on Capitol steps in 1922 stunt to demand overdue payment from the U.S. Navy.**

**Elmer A. Sperry with his son, pilot Lawrence Burst Sperry, an inventor in his own right, with 23 patents pending or granted, including one for a self-contained parachute.**

military to shelve the idea. It wasn't until after their deaths, that interest in their idea was rekindled, driven by the eruption of WWII.

The Sperrys encountered similar luck with another project they first pitched to the Navy in 1916 - "air bombs," or early guided torpedoes. "It's easy to imagine a fleet of these weapons, loaded with deadly gas or explosives, launched against an objective without endangering one human life of the side so employing them," explained Lawrence in papers published in 1926 after his death. Even though Lawrence's company developed and patented a remote radio-controlled aerial Torpedo, and Elmer applied for a patent on a radio-controlled aerial torpedo in December, 1917, this work too was tabled by the Navy once the war ended. Lawrence's patent foresaw the needs of modern cruise missiles, addressing internal guidance systems and post-launch guidance, among other issues,

After the war, in 1919, Sperry built two 48 ft. wingspan Land and Sea Triplane Amphibians for the U.S. Navy for coastal defense. With encouragement from Gen. Mitchell, he also designed a compact sport biplane for the Army Air Service in 1921.

The Sperry Messenger ran on a 28 hp, 3-cylinder radial engine, had a 20-ft. wingspan and could hit speeds of 95 miles per hour. His company also built the Verville-Sperry Racer for the Air Service featuring a retractable landing gear and a clean wing design. It won the 1924 Pulitzer Trophy Race.

Nicknamed "Gyro," Sperry was a

daredevil whose personally tested many of his instruments and technologies, included a public demonstration of his self-packing parachute. According the National Aviation Hall of Fame, Sperry jumped out of a plane, "falling 2,000 feet before pulling the rip cord. Unfortunately, winds carried him over downtown Dayton [Ohio] and he landed on top of its tallest building, as fire engines rushed to the scene. But when Lawrence calmly jumped from the building and floated safely to the ground, his father, an ardent prohibitionist, deadpanned, "I think we all need a drink!"

Other stunts included buzzing the Capitol to disrupt Congress and landing first on the Capitol steps, and then in front of the Lincoln Memorial before storming into the U.S. Treasury to collect money the government, which had been slow in paying his company for contracted work. Speaking of stunts, he is also considered by some the founding member of the "Mile High Club," in 1916 after he and a married woman companion were fished out of the drink off Long Island buck naked after their plane crashed. Sperry famously claimed the impact blew their clothes off, inspiring an equally famous retort by one New York newspaper, "Aerial Petting Leads to Wetting." He wasn't so lucky in another accident. Sperry was killed in a plane crash over the North Seas in 1923 while flying in dense fog from England to Holland in a plane he designed himself. Sperry is a member of the Naval Aviation Hall of Honor and the National Aviation Hall of Fame.

**((WIRELESS))**

**COMMUNICATE CLEARLY ON THE WATER WITH WIRELESS HEADSET SYSTEMS FROM DAVID CLARK**

David Clark Company Wireless Headset Communication Systems provide clear communication as well as freedom and mobility for crew members without being tethered to the vessel. Ideal for work boats, law enforcement and Coast Guard vessels, offshore service vessels, tugs and more. Go wireless on the water and trust David Clark for critical communications.

For more information call **800-298-6235** or visit **www.davidclark.com**

**David Clark**

Made in USA

© 2014 David Clark Company Incorporated  
© Green headset domes are a David Clark registered trademark. [WWW.DAVIDCLARK.COM](http://WWW.DAVIDCLARK.COM)



# AGOR 27

## R/V Neil Armstrong

(Photo courtesy of Gary McGrath, WHOI)

By Kathleen Gleaves

The ship as it was moved into the water at Dakota Creek Industries shipyard in Anacortes, Washington.

On March 29, the Ocean Class Auxiliary General Oceanographic Research (AGOR) vessel hull number 27 started its official life as the R/V Neil Armstrong, the first research vessel named after a space explorer. Carol Armstrong, the widow of the famed astronaut, performed the christening duties during a brief sunbreak on a windy and rainy Pacific Northwest afternoon.

The number of illustrious speakers highlighted the rich diversity of agencies involved in the design, construction and operation of the vessel. Dick Nelson, President of Dakota Creek Industries (DCI), the construction shipyard, spoke first followed by Chris Chuhran, VP of Guido Perla and Associates, Inc. (GPA),

the Seattle-based Naval Architecture and Marine Engineering firm that partnered with DCI for the design and build project. Chuhran said even though the keel was laid in June of 2012, the entire process had actually taken several years from its earliest idea phase to today's ceremony. The final detail design evolved over many months with frequent reviews by NAVSEA, the Office of Naval Research (ONR), the National Science Foundation (NSF) and the University National Oceanographic Laboratory System (UNOLS). On several occasions, DCI hosted review meetings attended by more than 40 people.

Rear Admiral Jonathan White, USN, said the R/V Neil Armstrong would help the Navy and the United States "...know

the ocean better than anyone else," much like Armstrong's trip to the moon helped us know the lunar world.

Chief of Naval Research, Rear Admiral Mathew Klunder, declared it a "magnificent vessel" that was "made and designed for the future."

Dr. Susan Avery, President and Director of Woods Hole Oceanographic Institution (WHOI) assured Mrs. Armstrong that her "husband's legacy lives on in his namesake ship." She described the ship as a "high-tech marvel" that is expected to perform its 40-year mission with distinction. The R/V Neil Armstrong will replace the R/V Knorr, in service since 1968, one year before Armstrong's walk on the moon. The R/V Knorr, AGOR-15, is retiring after logging over one

million miles in service to the Navy and WHOI.

Guests at DCI's Transit Shed ceremony had only a short time to admire the sleek lines of the ship before tugs, taking advantage of the high tide, moved her back to the shipyard for completion of the interior systems.

Commissioning and finish work should be completed by August, followed by sea trials, after which the ship will then spend an additional six months in the Puget Sound area training the crews and adjusting the equipment before she heads for her new home port at WHOI in Massachusetts.

Initial vessel construction for the two-ship, \$145-million-dollar project is funded by NAVSEA who will retain

ownership of the vessel. Scientists from WHOI and around the world will be the primary users conducting year-round research in the North Atlantic and Arctic Oceans. WHOI will contribute \$350,000 a year for maintenance and operation of the vessel.

Dr. Avery praised the modern design and ample computer lab space available on the R/V Neil Armstrong allowing scientists to analyze collected data in real time. She explained that the National Science Foundation (NSF) handles the complicated process of coordinating and scheduling research time on the ship. Pre-vetted, endorsed and funded projects are scheduled based on multiple factors; minimizing transit time, maximizing science time, matching and timing schedules and the number of days needed onboard. "Scheduling ship time in an integrated, inter-disciplinary way is a big planning effort," said Dr. Avery. Research will include mapping of the seafloor, launching of buoys, ROVs and other equipment, studying how currents affect acoustic signatures, microbial content of the northern waters, discovering how climate change and sea level rise are impacting the North Atlantic, and how the ocean in turn impacts climate changes. The focus will be on the entire eco-system. The physics, biology and chemistry of the high latitude oceans will fall within the Neil Armstrong's mission area.

### Design Team

GPA was hired by DCI to provide a Basic Design during the Phase I NAVSEA design competition. When the team's design was awarded the build contract in October 2011, GPA's engineers and Naval Architects went to work on the detail design and production engineering. GPA collaborated with Siemens Marine for the propulsion and automation systems. Siemens will be designing, engineering, and commissioning the diesel electric and automation system.

GPA and DCI have partnered on projects in the past ranging from a Navy Sea Jet, an Advanced Electric Ship Demonstrator, to fire boats, ferries, tugs and trawlers. Both companies have worked on multiple Navy projects independently as well.

### Shipyard

Dakota Creek Industries (DCI), located in Anacortes, Washington since 1975, began construction on AGOR 27 in mid-2012. The Navy exercised its option for a second vessel in February, 2012, and the shipyard began shifting its workload

around to fit the second vessel into the schedule. Hollie Anthonysz, DCI Program Manager of vessel construction, said the shipyard's first experience as the sole source on a military ship was posi-

tive and they are looking forward to the launch of the second ship.

DCI is a Puget Sound shipbuilding and repair facility specializing in steel and aluminum vessels up to 450 feet and

275 tons. Located in the deep waters of the Guemes channel, it offers a protected harbor with easy access to Pacific waters. Its facility includes a Syncrolift ship lift and a drydock.

**Reach ILS customers around the world with one click!**

- Search a marketplace of qualified buyers and sellers
- Discover a company's capabilities in their online profile
- Advertise to marine buyers when they are looking to buy
- Receive automatic alerts when you have a requested part in stock



We offer solutions to help your business grow. Contact us today to qualify for a **Free** trial.

**Inventory Locator Service,® LLC** • Email: [marketing@ILSmarine.com](mailto:marketing@ILSmarine.com) • [www.ILSmarine.com](http://www.ILSmarine.com)

Offices in: Atlanta, Boston, Dallas, Dubai, Frankfurt, Istanbul, London, Los Angeles, Miami, New York, Paris, Philadelphia, Phoenix, Seattle, Shanghai, Singapore, and St. Louis



## TOTAL WELDING SOLUTIONS

Wilhelmsen Ships Service introduces a complete new range of Unitor welding machines with total protection and low open circuit voltage designed to keep welders safe and operational efficiency high.

We also offer welding safety inspections, providing confidential assessments of the safety and operational conditions of welding and gas equipment on board.

Please visit our online product catalogue to find out more.

**UNITOR**



[www.wilhelmsen.com/shipsservice](http://www.wilhelmsen.com/shipsservice)

(Courtesy of Karla DeCamp, Dakota Creek Industries)



Breaking the champagne bottle to official christen the R/V Neil Armstrong.



**Left:** Carol Armstrong, wife of the ship's namesake, astronaut Neil Armstrong, addressed the crowd of visitors at the christening event at Dakota Creek Industries in Anacortes, Washington.



**Right:** Kali Armstrong watches her grandfather's namesake ship pulling away from the pier.

(Courtesy of Karla DeCamp, Dakota Creek Industries)



Portrait of the dignitaries assembled for the christening of the R/V Neil Armstrong. Guests from the US Navy, NOAA, NASA, Woods Hole, Dakota Creek Industries and Guido Perla Associates were on the dais along with members of the Armstrong family.



(Courtesy of Guido Perla and Associates)

**AGOR 27 Neil Armstrong Main Particulars**

|                         |  |
|-------------------------|--|
| Yard .....              | Dakota Creek Industries (DCI),   |
| Designer .....          | Guido Perla and Associates, Inc.   |
| Owner .....             | NAVSEA   |
| Operator .....          | WHOI   |
| Organizations..         | NAVSEA, the Office of Naval Research (ONR), the National Science Foundation (NSF) and the University National Oceanographic Laboratory System (UNOLS), Woods Hole Oceanographic Institution (WHOI) |
| Class .....             | ABS  |
| Main engines .....      | Cummins  |
| Cranes .....            | Allied Marine  |
| Winches .....           | Markey Machinery   |
| Sonar .....             | Kongsberg Maritime   |
| Survey .....            | Sonardyne  |
| Schat Harding.....      | Rescue Boat Davit SA135  |
| Schottel .....          | Stern Thruster 1x 620kW (830 HP)   |
| White Gill .....        | Bow Thrusters 1x 686kW (920 HP)  |
| MTU.....                | Emergency Generator 1x 210kW (280 HP)  |
| Propulsion System ..... | Siemens Marine   |

Over the next two months, Siemens will be installing their new Blue system. This advanced, multi-drive, low-voltage system manages the speed of various AC propulsion motors controlling the propellers, stern thruster and bow thruster. The system provides enhanced reliability with multiple failsafe features, lower maintenance costs, increased efficiency, and increased operational ease for the crew. Reduced fuel consumption results in lower greenhouse gas emissions. Siemens is also supplying the majority of the electrical switchgear, the ACCU automation, and condition-based monitoring system.

**Markey**

- 2x type CAST6-125 Deep Sea Research Winches with active motion compensation
- 1x type DETW-9-11 All-Electric Traction Winch System with two storage drums
- 1x instrumented flagging block
- 1x ship board wire monitoring system
- 1x type WES-23 Electric Anchor Windlass with two wild cats and two warping heads.

**Kongsberg**

- Deep Water Multibeam Survey System EM-122
- Mid Water Multibeam Survey System EM-710
- Single Beam Survey System EA-600

**Allied Systems**

- Stern Frame A-30
- Main Crane TK70-70
- Portable Crane TK4-30
- CTD Handling System CTD-Lars
- Starboard Side Handling Device

## Design Specifications

The vessels were designed for global operations in support of national security interests in the marine field, and other national oceanographic scientific endeavors. The ships are 238 ft in length overall, have a sustained speed of 12 kts, can stay at sea for a minimum of 40 days, and travel over 11,000 nautical miles without refueling.

In addition, they have the most modern scientific laboratory facilities and workshops afloat, high-tech computer and oceanographic equipment and hotel facilities to support 24 scientists and a crew of 20. They are built to ABS Under 90 Meter rules, and will be certified as A1, Circle E, AMS, ACCU, NIBS, Ice Class D0, and UWILD. The design is also compliant with 46CFR Subchapter U (Oceanographic Vessels).

Working deck space is a premium in oceanographic work. The AGOR vessels have 2,557 sq. ft. of clear deck space with 1,873 sq ft of that space on the open aft deck. Design specifications included being fully operational in Sea State 4 and able to handle dynamic positioning relative to a fixed position in Sea State 5 with a 35-knot wind and 2-knot current.

Additionally, the ship had to be as operationally quiet as possible. A great deal of ocean research involves listening. Excessive ship noise would negate that effort. GPA's unique hull design meets the Bubble Sweepdown performance requirement of the original specifications by diverting bubbles away from the sensitive sonar area. Model tank tests performed in Poland confirmed the Phase 1 design efforts met the Navy's exacting standards. Completing the noise dampening goal, designers chose systems, defined equipment locations and designed special installation methods with acoustics as a priority.

## Equipment

DCI has teamed with a multitude of local, national and international vendors to outfit the ship with the best equipment available, meeting the various needs and requirements of the scientists for a quiet, efficient, fully integrated and highly resilient blue-water platform from which they can perform their experiments and studies.

Over the next two months, Siemens will be installing their new Blue system. This advanced, multi-drive, low-voltage system manages the speed of various AC propulsion motors controlling the propellers, stern thruster and bow thruster.

The system provides enhanced reliability with multiple failsafe features, lower maintenance costs, increased efficiency, and increased operational ease for the crew. Reduced fuel consumption results in lower greenhouse gas emissions. Siemens is also supplying the majority of the electrical switchgear, the ACCU automation, and condition-based monitoring system.

The vessel uses four vibration-isolated Cummins QSK38-DM main generators providing a maximum of 3952 kW integrated electric power for all functions of the ship, including propulsion. The integrated diesel-electric plant allows for multiple generator configurations, ensuring the diesel engines operate at peak efficiency at all times.

A unique feature of the electric propulsion will be a "combinator" style control function integrating management of motor speed and propeller pitch on the Hundested-supplied Controllable Pitch Propellers.

Although fairly common in controllable pitch systems with direct drive diesels, use of the combinator control is unusual in variable-speed electric drive systems. The combinator increases operational flexibility by allowing the operator to set the propeller at its most effi-

cient setting across a range of operations including heavy towing and cruising.

Design specifications were stringent for deck cranes and winches. They needed the capacity to load equipment weighing more than 20,000 pounds including the deployment of ROVs, buoys and other heavy equipment. The stern frame required a minimum of 12-foot inboard and outboard reach. As designed, the frame provides 15 feet of clearance above the deck and 27 feet of clear space between the block attachment points, all while maintaining a Dynamic Safe Working Load of 30,000 pounds through the full range of motion. Allied Marine supplied the stern frame along with the portable TK4-30 portable crane and the TK 70-70 aft-deck Main Crane. They also supplied the Motion Compensated CTD Handling System and the Starboard Side Handling Device, both of which extend to the waterline for improved safety and load control.

Seattle based Markey Machinery supplied two electric-motor driven CAST-6-125 Hydrographic Winches, and the DETW-9-11 Traction Winch, both with AC Variable Frequency Drives System and electric motors for precise control.

Kongsberg Maritime, a 200-year-old Norwegian company, produces a full line

of specialty SONARS used in scientific research, fisheries and oil exploration. For Phase III of the project, Kongsberg will supply advanced SONAR systems. Although specifics are not confirmed at this time, projected equipment includes deep water and mid-water Multi-beam units, a HiPAP Gantry with a Sonardyne single beam survey system, and a SONAR Synchronization System. A Sub-bottom Profiler SONAR is expected as well. Additional equipment plans include a Transducer Array, a Mid-water Echo Sounder, and three Current Profilers operating at different frequencies, all are scheduled for installation in Phase III, subject to change as the project progresses.

AGOR 28, the second vessel in the Armstrong Class, will be named R/V Sally Ride in honor of the first female astronaut and the youngest person to go into space. The R/V Sally Ride will be operated by Scripps Institution of Oceanography, University of California, San Diego, where Ms. Ride was a faculty member before becoming an astronaut. The second vessel will mirror the basic ship equipment with some variations in the scientific outfitting. The christening date for the Sally Ride is scheduled for later this summer.



**YARDS TRUST BRUNVOLL**

A complex ship.  
A sophisticated thruster system.  
A tight installation schedule.  
No margin for delay.  
We know how it is – in Finland, Germany, France, Korea or China.  
With our specialized in-house expertise and years of experience, we have built up a reputation for preparing the units on time, precisely according to the specifications.

**TRUSTED WORLD WIDE**

TUNNEL THRUSTERS   AZIMUTH THRUSTERS   LOWNOISE THRUSTERS   BRUCON THRUSTER CONTROL SYSTEMS

**BRUNVOLL**  
BRUNVOLL AS - 6415 MOLDE - NORWAY  
www.brunvoll.no

# Marine Propulsion

*When talk turns to marine propulsion and the host of surrounding topics – emissions, efficiency, fuel consumption – we turn to class for answers. While there are just two questions, the ensuing answers from leaders at ABS, BV, ClassNK, DNV GL, LR and RINA are voluminous & enlightening.*

*By Greg Trauthwein*

**As the industry has been faced with simultaneous regulatory & market pressures over the past five years, what do you consider to be the most influential changes to the vessel and why?**

• **Paal Johansen, DNV GL**  
The stricter environmental regulations and rising fuel costs lead to technology development in design, size, propulsion and operations. This goes well beyond LNG as fuel, and we believe we will see a more diversified mix, with batteries, hybrids, methanol and so on.

• **James Watson, ABS**  
The traditional focus on class has been on certifying the safety of steel structures. Today, with the increasing emphasis on safety from the environmental perspective, the focus has shifted from structures to systems, looking at optimization of the hull form and of the equipment onboard.

Traditional physical model testing remains an essential component of hull

form development, but analytical techniques, such as Computational Fluid Dynamics (CFD), have come into their own software able to handle the complex calculations required.

Arriving at the most efficient vessel requires looking at the hull and the associated appendages – propeller, rudder, energy saving devices, bulbous bow (or no bulb) – as a complete and integrated system.

This also extends inside the ship to the type of central power plant, efficiency of onboard systems and energy management, fuel choices and measures to reduce consumption, compliance with emission standards for SOX and NOx, ballast water and underwater noise.

This is increasingly facilitated through technologies utilized onboard to moni-

tor, record and assess performance. ABS is continuing to improve its products and services to enable an expanding scope of transparent sharing of performance data between the owner and class to assist in this process.

This sharing of data is also laying the path for a shift in the near future, away from traditional prescriptive requirements towards more risk-based classification activities, such as annual surveys. This will be made possible by class and industry working closely together to share information and have a better understanding of performance of both ship structures and the associated onboard systems.

• **Noboru Ueda, ClassNK**  
Without a doubt, the biggest change

## Representing “Class”

- **James Watson**, President & COO, Americas Division, ABS
- **Philippe Donche-Gay**, Executive Vice president and Head of the Marine and Offshore Division, Bureau Veritas
- **Noboru Ueda**, Chairman & President, ClassNK
- **Paal Johansen**, Head of the Americas Region for DNV GL – Maritime
- **Tim Protheroe**, President, Lloyd’s Register North America, Inc.
- **Roberto P. Cazzulo**, RINA



Watson



Donche-Gay



Ueda



Johansen



Protheroe



Cazzulo

we've seen has been the shift towards more efficient and greener ships. As you say, this is happening both as a result of market forces such as bunker prices, as well as new regulations such as the EEDI. It's only been a few years since the industry really started to work towards innovating more efficient vessels, but we're already seeing very impressive improvements in terms of improved fuel efficiency and EEDI scores. At the same time, new GHG reduction technologies like air lubrication, and new low friction paints are just now entering commercial use. We're now seeing the first fruits of efforts towards GHG reduction, and I think that we'll see even more impressive technology, and even greater benefits in the years to come.

• **Philippe Donche-Gay, BV**

Size is the big thing. Chasing economies of scale by building bigger container ships has posed massive challenges for designers, yards and class. We have invested heavily in tools to understand and analyze structures for these ships. Size is an issue that will not go away and we have to stay ahead of it by working harder on structural fatigue.

• **Roberto P. Cazzulo, RINA**

There is a set of regulations that may affect, in a positive manner, shipowners' earnings this year and in the future. It is about ship's energy efficiency that is much wider than just green house gas (GHG) emissions and includes any sort of fuel savings and means to enhance energy efficiency. The IMO EEDI regula-

tion for new ships is entering into force and will become more and more demanding. Phase 3, foreseeing a 30% reduction with respect to current EEDI baseline by 2020, will require innovative designs and technologies used on board. IACS will reiterate its proposal to establish an IMO EEDI database for future verification of new ship performance. Class societies may record these data during the new building verification and sea trials. This matter is linked to the present booming of new so-called "ECO-ships" that are entering the market. The specification of these ECO-ships is not fully consistent and their actual performance needs to be proved during operation. It is the reason why we are closely following the development of monitoring, reporting and verification regulations for

existing ships. Hopefully, the IMO will play a leading role on these issues, in the context of SEEMP regulations.

• **Tim Protheroe, LR**

The simple fact of uncertainty or multiple options in fuel and propulsion choices is driving change where previously, for most, there was little choice. But perspective is important – for most, change will be gradual. Efficiencies are being captured but most important is a change in attitude – within a short space of time fuel has become the big OPEX factor and, combined, with emissions regulation, the industry is changing the way it behaves. Our role is to help the industry make the best possible commercial decisions based on the technical insight and expertise we offer.

**OmniTHRUSTER™**  
Marine Maneuvering and Propulsion Systems

**UNCOMPROMISED CONTROL**

JT Series

HT Series

- Low Submergence Requirement
- Small Hull Penetrations
- Auxiliary Propulsion/ "Take Home" Capability
- Effective Thrust in Currents
- Proudly Made in the USA!

Waterjet Bow/Stern Thrusters  
Up to 2,200HP

2201 Pinnacle Parkway • Twinsburg, OH 44087  
(330) 963-6310 www.omnithruster.com

**WE POWER YOUR BUSINESS**

**YOUR BEST CHOICE**

FOR RELIABLE POWER FROM 40kW to 250kW

When reliability is critical you need an engine you can depend on. That's why we use **John Deere PowerTech™** engines which are durable, fuel efficient, and easy to maintain. They are also backed by the support of one of the strongest engine and equipment companies in the world.

On the inland waterways, your generator set powers your bottom line. When you choose a power generation package from **engines, inc.**, you can rest assured that you are getting the best engineered package available anywhere and we stand behind it with the most reliable 24/7 support structure in the business. Our extensive dealer network is able to provide reliable service and dependable support wherever you are, whenever you need them and our skilled staff is always available on our 24-Hour Service Line.

**24-HOUR SERVICE LINE**  
**870-268-3799**

With over 150 years of collective experience in our shop and over 75 years of partnership with John Deere, we are, without a doubt, your best choice for Generator Sets and Propulsion Engines on the inland waterways. Our experience distinguishes us and our integrity sets us apart. When everything is on the line you can count on us: **We Are Your Power Source.**

**engines, inc.**  
Your Power Source

**INTEGRITY SETS US APART**

engines, inc.  
Jonesboro, AR • 800-562-8049  
Conroe, TX • 936-441-5592  
www.enginespower.com

**POWER**

**AUTHORIZED JOHN DEERE ENGINE DISTRIBUTOR**

**LNG As Fuel continues to pick up support. Looking at the looming emission and fuel regulations to and through 2020, please comment on how you see “LNG as Fuel” evolving in the coming six years?**

• **Tim Protheroe, LR**

We see an increasingly important future for LNG as a marine fuel and particularly in North America. Right now LNG is being taken up mainly by smaller ferries, by short-haul Jones Act containership operators, and OSVs. Lakes operators are likely to be next. Gas is relatively cheap and abundant in North America – we classed the first LNG carriers and with the largest share of LNG carrier classification we are well placed to offer the gas technology support and risk management that shipping needs as gas-as-fuel evolves. Today we are involved in LNG-as-fuel projects in North America and around the world. Our work with the Port of Singapore is helping set a template for the development of LNG bunkering in major ports.

• **Paal Johansen, DNV GL**

Considering the barriers to LNG as a fuel up until now, we believe that LNG as a fuel is an “all, or nothing at all” proposition. And we have reached the tipping point. It used to be said that LNG was a chicken or egg problem, but in the US we not only have the egg, but the chicken and the henhouse too. As we see this trend grow, DNV GL is working to ensure that owners can be confident that the technology is vetted, operational practices such as bunkering and crew training are in place, and the supporting infrastructure is meeting stringent safety standards. We are also working for the US Government and IMO to determine and remove the barriers to develop the necessary infrastructure and regulation for the supply side of LNG as a fuel. As a curiosity, the LNG fuelled ferry operating between Buenos Aires and Montevideo is the world’s fastest commercial ship at over 58 knots (classed by DNV GL), and I think this is a good indication also of how fast we will see a change in this field. The growing number of large LNG ready ships currently being built is also evidence of this.

We think North America and then Europe will be the first to get everything in place, soon followed by Singapore, China and Australia. So in 2020, we believe LNG is the standard for short sea shipping in North America and around the North Sea. For deep-sea shipping we believe that some routes between Asia, North America and the North Sea area

will have the infrastructure in all ends to support bigger ships. With the infrastructure set to be widely available in 2025, we are already seeing a rush of investments to strengthen this trend.

• **Roberto P. Cazzulo, RINA**

The use of LNG as fuel is a fundamental matter that will further progress in the next years, in particular for short sea shipping and internal navigation. The NOx Tier III and SOx emission limits in designated ECAs (including North America and US Caribbean Sea) and SECAs (currently the Baltic and North Seas) will drop. Dedicated & reliable emission control technologies, such as exhaust gas recirculation, selective catalytic reduction, scrubbers are needed. Instead, LNG may be used as a viable alternative. However, a lot of issues are to be resolved, both on board, for LNG storage capacity, and ashore, in particular looking at ships’ integration with regasification plants and bunkering stations.

Such a network of bunkering stations is presently not available, except in Norway and some ports in the Baltic Sea. The situation is rapidly evolving in the US, where large amounts of natural gas will become available. In Europe, there is an on-going study that hopefully will lead to some concrete proposals in the near future for short-sea shipping in the Mediterranean and Black Seas. We are working on it and we have technical know-how, for instance in floating re-

**YOU KNOW IT WHEN YOU SEE IT**



Suncor Energy uses HoldTight® 102 to remove salts from its FPSO Terranova and other similar vessels in the North Atlantic every time it re-coats decks, structural steel, piping and other surfaces exposed to the sea. PHOTO COURTESY OF SUNCOR ENERGY

**NO FLASH RUST = A CLEAN SURFACE**

HoldTight® 102 is the standard of performance for preventing flash rust:

- **NO SALT.**  
Removes all contaminants
- **NO RUST.**  
Leaves a rust-free surface for 48 hours or more – often 3 to 5 days
- **NO DETECTABLE RESIDUE.**  
There is nothing left on the surface that might interfere with your coating.

Among rust preventers and salt removers, HoldTight® 102 is the most widely used, reliable, time-proven, lab-tested, field-tested, recommended and approved by coating companies.

Call, email or visit our website today to see why HoldTight® 102 is the best option for low-cost, easy-to-achieve, and easy-to-measure contaminant-free surface preparation.



Contact us today!  
International +1 713 266 9339  
1 800 319 8802 (Toll Free in N. America)  
sales@holdtight.com  
www.holdtight.com



DNV GL



gasification plants, to contribute to these developments.

• **Philippe Donche-Gay, BV**

We see an accelerating move to use LNG as a fuel at sea and we are working hard with shipowners and gas suppliers to facilitate that transition. We are deeply involved with new ship projects, such as the gas powered ferry, the largest to use LNG yet, to be built for Brittany Ferries, and with gas suppliers such as Gas de Suez which is developing the small scale LNG vessels which will be needed for the bunker chain.

• **Noboru Ueda, ClassNK**

As the use of LNG as a fuel can lead to both reduced fuel costs and make it easier to comply with environmental regulations, we think there is tremendous potential for the widespread use of LNG as a fuel in maritime industry. However, just how far the use of LNG as a fuel will spread over the next six years will depend on a number of factors, including the number of ports developing LNG bunkering facilities, as well as the status of rules and standards related to use of LNG as a fuel at the IMO and ISO. If international rules and regulations can be agreed upon in a timely fashion, and a critical mass of ports can provide LNG bunkering facilities over the next six years, then I think we will see the use of LNG as a fuel spread worldwide.

• **James Watson, ABS**

Right now, we see a lot of excitement around LNG as fuel and for good reason. But while it is true to say we are past the initial tipping point, there is still a need for owners to be realistic about the decision to use LNG and the practicalities, once that decision is made.

Certainly there is a drive to adopt LNG for reasons of regulatory compliance, primarily in the current ECAs to meet upcoming limits for SOx and NOx and this will radiate out as new ECAs are adopted.

Perhaps as important to shipowners is lifecycle cost in the context of the other solutions available to address the same issues. LNG as fuel is still a big bet, but attractive compared to some other alternatives because it provides a near-single solution. It will meet ECA sulphur emission requirements and depending on type of engine solution selected, may also meet NOx emission requirements.

The decision to go 'all-in' on LNG must take into account the vessel design, how it is operated, where and for what length of time. There are multiple design issues associated with making LNG fuel

the right solution.

In six years I would expect LNG to be available as a marine fuel in at least half a dozen US ports, because by then the ships will have been delivered that require it. Once that happens, I would

expect orders for more LNG-fuelled vessels to increase rapidly.

The only factor that would disrupt this development path is a change in LNG price or a major LNG-related disaster, two circumstances that look unlikely.

Not only is natural gas abundant in North America, the gas shipping industry is well aware that its almost perfect safety record in the shipping and storage of LNG in the last 50 years is something it must continue to defend.

**SERIOUS AIR FOR SERIOUS PLACES**



**AMERIC** Confined Space Ventilators

- 8", 12" & 20" Models
- Portable
- 877-10,000 CFM
- 110/220V
- Pneumatic

**EWAYCOOLE**

**Powerful Evaporative Cooling!**  
Reduce air temperature by as much as 20 degrees!

Schaefer is the leader in high quality industrial circulation fans, exhaust, misting, evaporative cooling and infrared heat.

**MADE IN THE USA**

**SCHAEFER**

sales@schaefefan.com • 1.800.779.3267 • www.schaefefan.com

Helkama Bica has manufactured cables for fifty years and roughly 80 % of the sales are exported to 60 countries. Helkama supply marine and offshore cables, optical fibre and instrumentation cables.



*The First 50 years*

For more information visit [helkamabica.com](http://helkamabica.com) or call +358 2 410 8700

more than you expected  
**HELKAMA**

ANCHOR WINDLASSES - RESCUE BOAT DAVITS  
CAPSTANS - ANCHOR WINCHES - MOORING WINCHES  
TOW WINCHES - REELS - CONSTRUCTION WINCHES



**COASTAL**  
MARINE EQUIPMENT, INC.  
GULFPORT, MS www.cmei.biz (228) 832-7655

**AMERICAN MADE**

**AN INVESTMENT WELL MADE**

Air Products nitrogen generators  
**When reliability matters**  
Now onboard more than 300 LNG carriers



Meet us at:  
Posidoniac, Πλοιαρχία  
The International Shipping Exhibition  
19-20 June 2014  
Stand 228 - Hall 4

Since 1982, Air Products offers low maintenance, economic, and easily installed nitrogen generation systems applicable to a wide range of nitrogen capacities, nitrogen purities and system physical dimensions.

**AIR PRODUCTS**

[www.airproducts.no](http://www.airproducts.no)

# WQIS

*An interview with Rich Hobbie, the leader of the Water Quality Insurance Syndicate (WQIS), the largest underwriter of pollution liability insurance for marine vessels in the United States. By Greg Trauthwein, Editor*

**Can you give our readers an overview of your business today.**

■ The Premium income and growth factors in the marine insurance industry are very stagnant right now. And competition is quite heavy in all areas. In the U.S. market and in the marine market in general, there are new players. The London market has gotten more aggressive over here.

**There has been a prolonged contraction among ship owners and operators. How has this impacted your business?**

■ To put it simply, there is not a big increase in marine transportation. (While there is a boom in the energy markets), a lot of the shale oil and gas is carried via pipeline and railroad car into various ports. (In short) today there are fewer, bigger ships.

**In the long range, do you see the shale oil and gas as having a bigger impact on the U.S. marine business, and as a result WQIS as well?**

■ There are two answers to that question. The first is "what is the U.S. government's position on energy export," because that will have an impact. And then you have to consider how the various states will react to the transit of the oil through their states. Barge are the safest means to transport oil. It has the best historic loss record and the best safety record.

**What else do you count as most recently impacting your business?**

■ The Macondo oil spill is impacting pollution cover fairly heavily.

**How so?**

■ BP made the decision to set up a \$20B dollar fund and, as a response to the spill, to throw at it every resource that could be found, whether or not that resource was productive or efficient. They established in the minds of a lot of responders who were new to response, because we haven't had a lot of big spills, an

idea of how a spill response should be run. And the BP fund paid claims that are not required, per se, by law.

So today oil spill responses, especially in the areas of the Gulf and lower Mississippi River, are taking on a different kind of life and are becoming much more expensive because there is an overreaction in terms of resources being put on the spill. There is an increase in inefficiencies in the responses because people trip over each other. It's just too much, and has built an expectation on the part of some parties that they deserve to be paid for claims that should not necessarily be paid.

**To what do you attribute this overreaction?**

■ I think they had a terrible public relations problem. I think they handled it brilliantly. I think they did a very good job for their own interests. And so that's why they reacted that way, and I would never criticize them for it.

**How does this have a material impact on WQIS and on insurance in general?**

■ The trickle over is simply the expectation of people from the liability side of insurance that have damage, whether or not from an oil spill, potentially may be looking for payments of claims that would not historically have been paid.

We have always expected over time that costs, comparatively as all other inflatable items, would go up on a spill. But we've seen a jump of expectations. To give you an example, when the government sets up a command center you need to run a good command center 24/7 and you probably need 60 to 70 people. Today, command centers are being set up with 300 to 400 people.

And you just have to wonder what they are all doing. The Coast Guard officer who ran the Houston Astro-dome evacuation after Katrina set up the emergency response, set up a shelter and hospital for approximately 25,000 displaced residents. He did it with 19 people. Because that's what you need. You need an efficient organization in the command center, but that's not how it works today. And you have to pay for all the people in the command center.

And that's the way it's evolving: everybody wants a piece of the spill. Everybody wants their input on the spill. They want to be in the command center where all of the action is.

**Let's discuss the price pressures you alluded to.**

■ The price pressures are not necessarily from the insured. Everybody would like to get the best deal, so of course you would like a reduction in your insurance payment, especially when you haven't had a claim. But what we're in is an insurer-driven price competition which is a little different. This is where insurers themselves would like a bigger piece of the market and may choose to write business at prices that, in the first instance don't seem economic, in order to get a larger piece of the pie.

**Legislatively, there has been some big activities with the advent of the new non-tank rules and firefighting rules, and the relationships between salvors and their clients. What does this mean for insurers in the oil pollution markets?**

■ The difficulty is that in a marine event, you can have Sue and Labor under the hull policy involved, you can have salvage involved, you can have removal of wreck involved, you can have cargo offloading to save cargo, and you can have pollution.

In the pollution world, you cover the threat of discharge or discharge. At what point does a vessel become a threat of pollution ... where the pollution underwriter should respond rather than the hull or the P&I or the cargo insurer. So when you offload a cargo from a grounded barge, is that for cargo interest? Is that for pollution interest? Is that for hull interest to refloat the vessel? So we have a situation where portions of a pollution event could be covered by none of them or all of them.

And therein lies a grave difficulty. You are an insured. You have paid to place your insurance with three best insurance companies in the United States. Then an event occurs. There is no doubt that you are covered, but who's going pay you? And that process of determining who is going to pay can take time, and you are

not getting your money while that's going on. So that is a problem for the industry that we are struggling to deal with.

#### Okay, so what's the solution?

■ I have raised the issue with the American Institute of Marine Underwriters. I have raised the issue with my subscribing companies. But if you make a formal decision to transfer the risk to only one entity (insurer), there has to be a commensurate premium. When you transfer it to that entity, it means that the other pieces (insurers) have to give the premium up. The other insurers are not prepared to give the premium up. Cleaning up the oil is not questionable. We know who covers that. If a bird gets oil-soaked, we know who covers that. But if we have to offload a grounded tanker, who covers that?

#### So what about the new non-tank vessel rules and the new firefighting rules.

■ Now you have a vessel response plan that is designed for how you're going to deal with a discharge, or a threat of a discharge of oil. But now you have a second section then, how are you going to deal with firefighting. But in the insurance market, they are not all covered by one person. So there are some difficulties there in that, and it also causes the Coast Guard to consider it to be one event, whereas from an insurance perspective it's multiple events. And now there are some issues regarding responder immunity. I won't name names, but there are three different groups: one group is in favor of the responder immunity; one group is opposed to responder immunity; and there is a third group that doesn't feel it is productive to reopen the OPA 90; They are scared to reopen the OPA. They may either agree with responder immunity, or disagree with responder immunity, but they feel that if Congress reopens OPA 90, it would not be limited to just responder immunity. And that's one of the big things that's coming out of firefighting salvage and all of that, and response to oil spills. There is a limited responder immunity in OPA for response organizations, but there is not the equivalent for firefighters and salvors.

#### We talk about the marine industry improving its environment footprint, what is your thought on that? What have you seen over the course of your career?

■ In 1973, the captain of the Port New York had 2,200 reported pollution events from facilities and vessels in the group New York region. I would be shocked if that number was even a hundred today. So the first thing that I've really seen in my career is OPA worked; OPA has worked very well.

#### And the environmental nature of this business has increased exponentially.

■ Absolutely. In 1973, the Coast Guard could go out, and when they sent in their pollution report, they could make a judgment if the oil was uneconomical to clean up. Can you imagine that now; can you imagine anybody being able to do that today? Or even wanting to?



#### What do you consider to be the greatest challenges to your business today and how are you addressing them?

■ A challenge would be an unknown change in the law. And that is what we are most susceptible to, as a challenge would be an event which causes the government to overreact and impose a different type of liability or different conditions of liability on the insured.

#### Would you say the trend has been toward the government overreacting to these types of events?

■ I thought that after Macondo that Congress would act, but it did not. There are other issues in the United States today, which I'm not going to talk about, but there are other issues that have the attention of our government. And the environment is not a high priority in terms of statutorily changing the laws, nor is there a great need for it. The laws we have are working very well. But the challenge would be the next major event. That's a challenge for us every year. A second challenge is that the individual states are becoming more active. There are at least 19 states now that impose unlimited liability on the vessel; no cap on the liability. Delaware was the most recent to change their law. That's a challenge for both response and for insurance.

#### When you look at the states, what do you consider to be... which states today are most aggressive?

■ Well, let's just simply say the most active.

#### Okay, 'most active.'

■ The west coast states historically. Florida is al-

ways a bit active. You never know with Massachusetts. But really the west coast states are the most active on these environmental issues, including Hawaii. And how are we addressing it? Well, we have a legal liaison on the west coast and he attends and sets up liaison with the government agencies and the legislatures. On the east coast we have a registered lobbyist in Washington, DC.

#### Just one more question: I saw you launched "Stories from the Sea Campaign," which I found interesting because I would assume that the last thing that anybody involved with insurable events would want to do is tell a story about it.

■ It has two purposes. One is education, and the other is engagement. Now, by engagement we want to get people to respond to us, because that's a stronger impression, that's a stronger involvement with WQIS' name brand.

Education is that people misunderstand how their liability could arise. I like to tell this story when I give a speech. A grandfather decides to take his two grandchildren fishing on the Hudson River. He has a 14-ft. Zodiac inflatable boat. He paddles out, he's got no engine. They're fishing and having a good time. The youngest kid gets rambunctious and throws the paddles over the side, the oars. Downbound is an oil barge and a tug captain sees them floating in the middle of the stream. The tug captain makes a fateful decision – he decides not to kill them, because he sees the children and he runs the barge around. The grandfather is personally liable for \$854,000 cleanup, which is the minimum liability for any vessel. And he is personally liable for that because he was the sole fault, 3rd party who caused the oil spill. We try to engage people to think about protecting themselves and their liability for the things they would have never thought of. It's education and engagement.



Wheeler



Holder



Harris



Roelse



Kunkler



Behrendt (L) & Hasbún

**Obituary: Wes Wheeler**

Wesley D. Wheeler passed away on April 18 in Stamford, Connecticut. He was 80 years old. He was laid to rest in Cyprus Hills Cemetery in Brooklyn, N.Y. Wheeler was an active member of the marine community for 60 years. He lived and worked in many countries and for some of the largest naval architects, consultants and shipbuilding companies in the world including JJ. Henry & Co., J. J. McMullen Associates, H.M. Tiedemann & Co, American Bulk Carriers, Sparkman & Stephens Inc., Astilleros Espanoles and M. Rosenblatt & Son. He founded his own firm, Wheeler Associ-

ates Ltd. and is a direct descendant of the Wheeler Shipbuilding Company and the Wheeler Yacht Company.

**Obituary: Len Holder**

Len Holder, Videotel Chairman, died April 21, 2014, after a short illness. Holder dedicated his life in the maritime industry to developing better training practices. After serving at sea for 10 years, he came ashore to undertake study and research at Liverpool Polytechnic, becoming Director of the School of Engineering and Technology Management over his time there. From 1989, Len acted as an independent consultant.

**Remembrance: Steve D. Harris**

EBDG announced that colleague Steve Harris and his wife Theresa were among those missing in the recent Oso mudslide disaster.

Although, at press time, Steve and his wife Theresa have yet to be found, the level of devastation wrought by the mudslide in Snohomish County makes it highly unlikely that authorities will locate any survivors. Harris leaves behind a legacy of work that spans more than 30-years.

He joined Elliott Bay Design Group in 1998, and quickly distinguished himself as an expert in advanced structural finite

element and hydrodynamic analysis.

**NOIA Elects Chairman, Vice Chair**

The National Ocean Industries Association (NOIA) Board of Directors has elected John T. Rynd as Chairman of NOIA and Cindy B. Taylor as Vice Chair of NOIA for the upcoming 2014-2015 term. Rynd and Taylor assumed their positions at the NOIA Annual Meeting.

**IHC Merwede Appoints Roelse CEO**

IHC Merwede appointed Bram Roelse as the company's new CEO effective April 1, 2014. He has taken over this leading role within the company from predeces-

**THE RIGHT CHOICE WHEN YOU NEED TO POWER UP**

**DF-656-40 ELECTRIC WINCH**



- Heaviest winch in its class
- Moisture-resistant, varnish-dipped motor windings
- Freewheeling & simple design

nabrico-marine.com  
615.442.1300

**NABRICO**

**MASSACHUSETTS MARITIME ACADEMY**

**Advanced Shiphandling in Manned Models**

Massachusetts Maritime Academy offers the USCG approved Advanced Shiphandling in Manned Models course. This training meets STCW requirements for assessing Management Level Deck Officers.



**Additional Training at MMA:**

- OPA-90 Qualified Individual
- Vessel/Company/Facility Security Officer
- Visual Communications (Flashing Light)
- STCW Basic Safety Training
- Medical Care/PIC
- Fast Rescue Boat
- Radar Observer
- ARPA/BRM
- Hazwoper
- ECDIS

Contact us for a complete training schedule  
Tel: 508 830 5005 Email: cmt@maritime.edu  
www.maritime.edu/cmt

**Three day course**

**Fatigue and Fracture Analysis of Ship Structures**



Houston, Texas, September 3-5, 2014

**Register now!**

The course reviews fatigue and fracture problems observed in marine structures and how they have been addressed, provides an introduction to material characterization assessment as well as quantitative procedures for fatigue and fracture design and assessment. The course is geared to naval architects, ship superintendents and engineers responsible for design, material specification, welding, operational safety and maintenance.

For detailed course content, visit our web site at [www.fleetech.com](http://www.fleetech.com). To register, email [training@fleetech.com](mailto:training@fleetech.com).

Accredited by SNAME for compliance with NYSSED guidelines for Continuing Professional Competency.

**BMT Fleet Technology** **ABS**



L to R: Carney, Traver and D'Isernia

(Photo: Eastern Shipbuilding)



Friedman



Pickles



Mammoet Repairs.



Fred. Olsen & MTN

sor Dirk Philips who stepped back in November 2013. Roelse has worked at IHC Merwede for the past 13 years. He was originally appointed as the Managing Director of the company's business unit IHC Systems.

**CLIMAX Names Scott Kunkler VP**  
CLIMAX Portable Machining & Welding Systems hired Scott Kunkler as Vice President of Global Quality and Engineering. Kunkler joined the CLIMAX World Headquarters in Newberg, Ore., on March 31.

**Hapag-Lloyd, CSAV Merger**  
Hapag-Lloyd AG and Compañía Sud Americana de Vapores (CSAV) signed a binding contract on merging CSAV's entire container business with Hapag-Lloyd, subject to the necessary approvals. Following the integration, the new Hapag-Lloyd will rank among the four largest liner shipping companies in the world, with some 200 vessels with total

transport capacity of around one million TEU, an annual transport volume of 7.5 million TEU and a combined turnover of 9 billion Euro. The company's head office will remain in Hamburg.

**Eastern Receives NYC FiFi Plate**  
At the Sea Air Space Exposition at the Gaylord National Convention Center - National Harbor, MD, Brian D'Isernia, Eastern Shipbuilding Group, Inc.'s president, was presented a NYC Firefighter Plate which honors the 343 NYC firefighters who sacrificed their lives during the 9/11 World Trade Center disaster. Eastern was the builder of the two 140' FDNY Fire Fighting Vessels now operating in New York City.

**ClassNK Executive VP Named to Green Award Board**  
The Netherlands-based Green Award Foundation has announced that ClassNK Executive Vice President Tetsuya Kinoshita has been selected to serve on

its Board of Experts from May 1, 2014.

**Friedman Named to US Marine Transport Council**  
U.S. Transportation Secretary Anthony Foxx appointed Port of Cleveland President and CEO Will Friedman to the Marine Transportation System National Advisory Council (MTSNAC).

**Pickles to Head KVH's Crewtoo**  
KVH Industries, Inc., said that Anneley Pickles has joined the company as Head of Business Development for the Crewtoo social network, the online network dedicated to seafarers. Top priority is overseeing Crewtoo Jobs, an online maritime jobs board launched recently.

**South Pole Telescope Finds Proof of Big Bang**  
Several media reported recently that the existence of the Big Bang allegedly has been proven. This was done by BICEP, a telescope stationed at the South Pole. In 2011, Mammoet replaced the bearing

of this monumental instrument, which now appears to have found 'waves of gravity' that were rippling through space right after the Big Bang. The waves were predicted by Albert Einstein nearly a hundred years ago, but never found until now. According to scientists, this is a landmark discovery that adds to our understanding of how the universe was born. This first direct evidence of so-called cosmic inflation - a theory that the universe expanded by 100 trillion-trillion times in the blink of an eye - was announced by experts at the Harvard-Smithsonian Center for Astrophysics. The South Pole Telescope was repaired by Mammoet in 2011.

**MTN, Fred.Olsen Extend Deal**  
MTN Communications (MTN) announced Fred.Olsen Cruise Lines has extended its four-year relationship with the company. Fred.Olsen chose to increase the breadth of communications, content services and support MTN provides.

**PosiTector<sup>®</sup> UTG**  
**Ultrasonic Thickness Gage**

**Wall Thickness and Corrosion Gage...**  
*Ideal for measuring wall thickness and the effects of corrosion or erosion on ship hulls, decks, bulkheads or any structure where access is limited to one side.*

- Choose **Standard** or **Advanced** features and **Corrosion** or **Thru-paint** probe
- Advanced models include A-scan, B-scan, Screen Capture and onscreen batch annotation
- All models include memory, statistics, USB

**UTG M Thru-Paint models** measure the metal thickness of a painted structure without having to remove the coating.

Also accepts coating thickness, environmental and surface profile probes

**DeFelsko**  
The Measure of Quality

1-800-448-3835 or [www.defelsko.com](http://www.defelsko.com)  
Ogdensburg, New York USA • Tel: 315-393-4450  
Fax: 315-393-8471 • Email: [techsale@defelsko.com](mailto:techsale@defelsko.com)

Made in U.S.A.

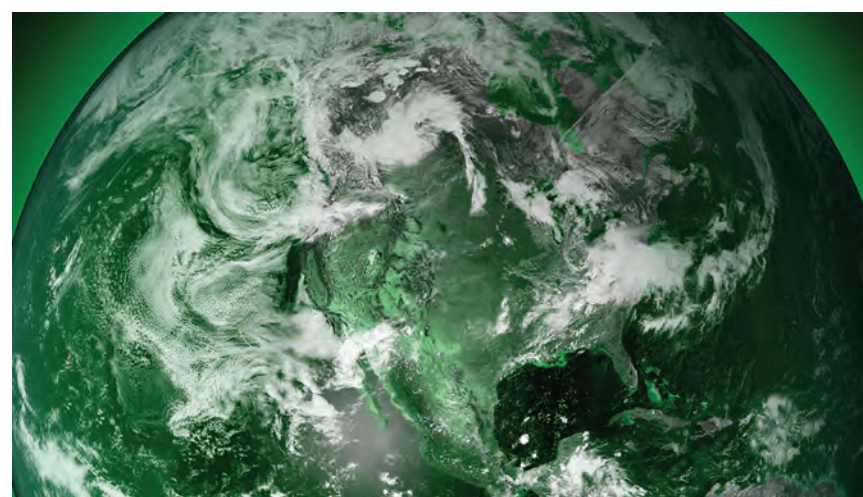

## Today's Frontiers Tomorrow's Front Lines

Delivering solutions to the most pressing operational challenges.



# Mammoet:



## World's Biggest Crawler Crane Installs Legs on Ship

Mammoet employed the LR13000, reported to be the biggest crawler crane in the world, to install four platform legs on Van Oord's newest wind turbine installation vessel, Aeolus.

In 12 days the giant crane was assembled at Lloyd Werft in Bremerhaven, Germany. The first of the four 87m long steel platform legs, each weighing 920 tons, were settled into its jacking position on the 139 x 38 m vessel. For the job, Mammoet designed, fabricated and

delivered tailor-made top lifting tools and a tailing frame to ensure that the legs, that have no lifting points, can be lifted securely. In addition to the platform legs, Mammoet will also install four spudcans, using a specially engineered method. This method involves placing the partly rigged spudcans on the seabed, moving the Aeolus over it and connecting the spudcan with the leg with the use of cranes and divers.

[www.mammoet.com](http://www.mammoet.com)

## ALP Tugs Get Rolls-Royce Deck Equipment

Rolls-Royce won a \$31.9m contract to deliver deck machinery for four ocean going tugs, designed by Ulstein Design & Solutions, for Dutch company ALP Maritime Services. The vessels will be constructed in Japan by Niigata Shipbuilding & Repair. The vessels are being developed for towing large structures like oil rigs and floating production units over long distances. The bollard pull for each of the four vessels will be 300 tons and

they will be equipped for anchor handling.

The deck machinery include a complete low pressure winch solution and a stern roller. The towing/anchor handling winches are specially developed in cooperation with the ship designer and owner. The supply of rudder and steering gear is also included in the Rolls-Royce scope.

The Ulstein design SX157 vessel will be delivered from Japan by Q1 2016.

[www.rolls-royce.com](http://www.rolls-royce.com)



# ANCHORS

## ANCHOR

LARGEST INVENTORY  
OF NEW & USED  
IN THE U.S.A.

FAX: 713/644-1185  
WATTS: 800/233-8014  
PHONE: 713/644-1183

# CHAINS

## MARINE

ALL TYPE  
ANCHORS & CHAIN  
ABS, LLOYDS  
GRADE 2, 3, K-4  
CHAIN & FITTINGS

P.O. BOX 58645  
HOUSTON, TX 77258

[sales@anchormarinehouston.com](mailto:sales@anchormarinehouston.com)  
[www.anchormarinehouston.com](http://www.anchormarinehouston.com)

## STAY AHEAD with the best

Maritime Associates, Inc.  
Marine & Offshore Signage Experts

# Signs

We Design, Produce and Install  
all signs and complete sign systems

775-832-2422

[www.MarineSigns.com](http://www.MarineSigns.com)  
[maritime@MarineSigns.com](mailto:maritime@MarineSigns.com)

Put the power of our experience to work for you



## Traction and Control System for Tugboat Winches

For Damen Shipyards, Bosch Rexroth developed and engineered both the hydraulic and electrical systems for the winches of a new tugboat.

The Damen ASD Tug 3212 is a newly designed tugboat for assistance activities at offshore LNG and oil terminals and open sea loading stations for the mining industry. The tug has 85 t Bollard Pull, a speed of 14 knots and two deck-mounted winches: one at the bow and one at the stern.

The winches are directly driven by the second-largest motor from the Håg-

glunds CB series. This compact and low-speed hydraulic motor features a low mass moment of inertia, high torque and minimal servicing needs.

The complete project comprised the pump sets, manifold blocks, motors, system controller, control cabinets and operator panels. Because Bosch Rexroth developed all the hydraulic and electrical systems needed – where they used proven components and technologies – the final solutions have a very compact design.

[www.boschrexroth.com](http://www.boschrexroth.com)

## Townsville Opts for a Liebherr LHM 420

Australian-based Northern Stevedoring Services (NSS) placed an order for a Liebherr mobile harbor crane, type LHM 420, to operate on Berth 3 and 4 in the Port of Townsville, Queensland. The operations of the stevedoring company span all of regional Queensland's major port

facilities, providing the full range of stevedoring and logistics solutions. The new crane is the third LHM crane for NSS, which has been operating an LHM 550 and an LHM 1300.

The crane comes with double supporting pads and software to assist in meet-

ing the quay limitations, along with Liebherr's Cycoptronic anti-sway system and a twinlift spreader. The LHM 420 is also fitted to operate with the Rotabox system for dust-free high-value mineral handling.

[www.liebherr.com](http://www.liebherr.com)



**SLM SUPERIOR LIDGERWOOD MUNDY**  
Commercial Sales Division  
Ph: (715)394-4444  
Fax: (715)394-6199  
sales@lidgerwood.com  
http://www.lidgerwood.com

**THE LATEST TECHNOLOGY IN COMMERCIAL DECK EQUIPMENT**

**Ballast Tank Level • Draft Monitoring**

**Level Transmitters**

- For newbuild or retrofit
- Hybrid bubbler technology
- ABS Type Approval
- Guided wave radar

email: [marine@king-gage.com](mailto:marine@king-gage.com) Phone 304-387-1200

**KING-GAGE® Marine Systems**

[www.king-gage.com](http://www.king-gage.com)

© KING-GAGE is registered trademark of ATC King Engineering

## Claxton's Camera Upgrade Puts Crane Safety in Focus

Claxton Engineering Services Ltd., an Acteon company, launched the latest version for its ATEX and safe-area crane boom cameras to improve operational safety through substantial upgrades in camera performance and its user interface. Enhancements to the camera, which according to Claxton is one in a range of best-in-class subsea and surface cameras, include state-of-the-art charge-coupled device (CCD) modules; a 324-1 digital zoom; and a 28× optical zoom lens. The new system also offers 3D noise reduction (3D NR) for low noise images in low light environments, image stabilization, better resolution (now 550

from 450 TVL) and a lower minimum illumination level (now 0.25 rather than 1 lux). The camera retains the auto/manual day to night switching feature for night viewing in monochrome. A joystick control replaces the push button system and enables operators to concentrate on the screen without looking at the controller.

The system includes a 12.1 in., high-resolution daylight viewable LCD screen and a control console that can be mounted on any suitable surface within the cab.

[www.claxtonengineering.com](http://www.claxtonengineering.com)



## Compact Hydraulic Manifolds for Safe Winch Performance



Anchoring of ships or depositing of cargo on the bottom of the sea – the potential uses for winches in marine and offshore areas are extremely varied. Safety is always the highest priority. With an additionally included valve in the control manifold DSE by Rexroth, the retention forces are maintained even when the brake is inactive. The compact construction type reduces costs and installation effort for the user.

With regard to winches the safety aspect is of utmost importance. If, for example, the hydraulics supply to the winch is interrupted without activation of a brake, in the worst case the load on the hook can fall uncontrollably. To guarantee safety even in these cases, Rexroth installed an additional valve that reacts to falling oil pressure. It keeps the oil in the hydraulic motor and thus prevents oil from escaping into the tank. While the motor will rotate slowly, it will not cavitate and the holding

forces will be maintained. The user can select between multi-disk brakes and a brake band, which affects the edge of the winch drum.

An automatic brake release function with integrated pressure reduction valve is available to release the brake.

The winch control valves of the DSE product line can be installed directly on the motor without the need for pipes or hoses. Thus, the manufacturer does not only save costs, but also installation effort. Eliminating the lines also avoids the risk of leaking hoses, pipes or couplings.

With a possible flow through of 60 to 700 l/min and a maximum pressure of 250 bars, the product line is primarily suitable for use with larger winches. Thanks to the modular design, the suitable control manifold can be adopted to the customer's requirements. Functions such as self-centering, operation with two speeds and mooring can be easily added to the main manifold.



## WASSP Goes Wireless with New Remote Mapping System

Multi-beam sonar manufacturer WASSP Ltd. debuts its latest system – now for super yacht applications. WASSP-Wireless has been designed to address one of super yacht captains biggest concerns; underwater obstacle avoidance. Ideally suited to use when navigating in unknown waters or where marine charts lack sufficient detail, WASSP-Wireless helps takes the risk out of the equation for the captains. Installed in the tender or support vessel of a super yacht, the WASSP-Wireless system uses a wifi radio link to send a real-time sea floor map back to the super yachts bridge system and display on a MaxSea navigation plotting platform in real-time.

Using a wide angle, multi beam transducer, WASSP-Wireless quickly and accurately covers the seafloor. With one pass at a depth of 20m, WASSP-Wireless will map a swath over 60m wide using 112 sonar beams and renders an information-rich 2D or 3D real-time image on the bridge.

Seafloor topography, rock or coral outcrops, obstacles are clearly identified giving large vessels the opportunity to navigate safely into or through areas that would have previously been seen as off limits.

[www.wassp.com](http://www.wassp.com)

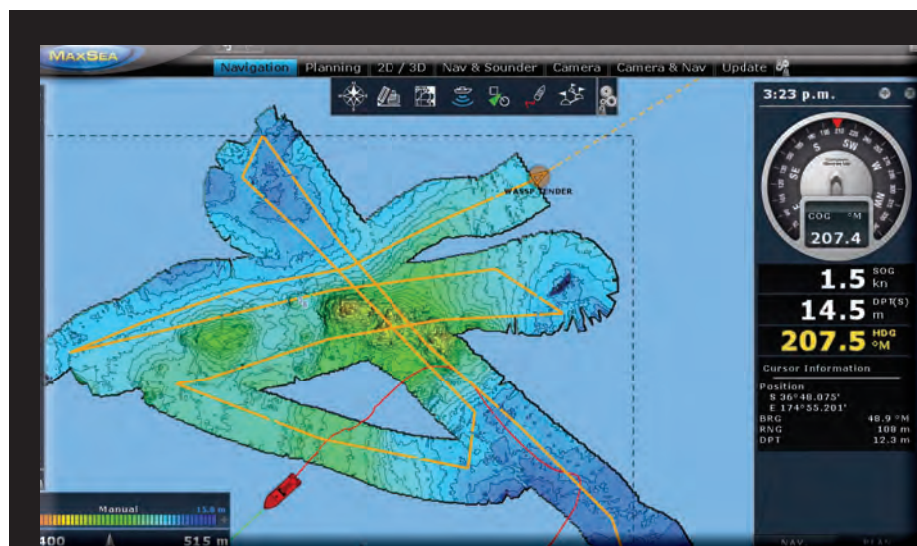

### Danelec's 3G VDR



Danelec Marine introduced its third-generation marine Voyage Data Recorder (VDR), the Danelec DM100 VDR. The new unit fully complies with the new IMO VDR standard which comes into effect July 1, 2014. It also incorporates Danelec's Software Advanced Protection (SWAP) technology – a new approach to shipboard servicing of marine electronics. "Danelec's SWAP solution saves time by removing the repair from ship to shore, reduces labor costs for service calls, protects valuable shipboard data and eliminates in-port delays for repairs," said Hans Ottosen, Danelec CEO. Danelec designed the VDR data acquisition unit for easy plug-and-play replacement, with all system programming and configurations stored on a hot-swappable memory card.

[www.danelec-marine.com](http://www.danelec-marine.com)

### ABB Energy Management System

ABB won an order from Spanish ferry operator Baleària to supply energy management systems for one of its largest vessels. ABB's advisory software will be installed onboard the ferry Martin i Soler, with options for additional vessels. The package supplied is envisioned to generate a more than 2% savings in propulsion power. The EMMA Advisory Suite is a decision-support tool to minimize the overall energy costs for individual vessels and entire fleets. This installation will cover dynamic trim optimization and hull condition monitoring. The package is designed to help the vessel operator to optimize required propulsive power and forecast hull and propeller fouling, with both contributing to reduced fuel consumption.

[www.abb.com](http://www.abb.com)



### Transas Liquid Cargo Handling Simulator



Transas Marine launched its new liquid cargo handling simulator LCHS 5000 TechSim LNG which reportedly is the first one in the market to boast ship-to-ship transfer functionality. The new Transas LCHS 5000 TechSim product line includes simulators for LNG tanker, LNG terminal and LPG carrier. Ship-to-ship transfer is a complex operation which requires adequate training to minimize the risks of damage to personnel, environment and assets. Transas LCHS 5000 allows for a complete resource management training involving crews of both mother and daughter vessels. The LNG vessel and LNG terminal simulator models were developed in collaboration with the Szczecin Maritime Academy, Poland.

[www.transas.com](http://www.transas.com)

### Color LCD Radar from SI-TEX



SI-TEX Marine Electronics launched its new T-760 Series Radar, which offers features like touch screen control, AIS target tracking and standard MARPA (Mini Automatic Radar Plotting Aid). SI-TEX T-760 Series' compact, slim case and vertically oriented, 7-inch (800X480 pixel) touchscreen color LCD display allow for versatile mounting options, even on small and/or crowded consoles and helm stations.

The T-760 Series case measures only 5.4 X 8.9 X 3.5-in. The series includes the T-760, equipped with an 18-in. compact radome antenna for solid performance in a wide range of conditions and range scale choices from 1/8th nm to 24nm.

[www.si-tex.com](http://www.si-tex.com)

### Martek: Network-Connected ECDIS

Martek Marine released its unique ECDIS offering to the market: iECDIS, which the company claims is the first model to integrate a GSM modem, offering automatic download and installation of charts, updates and notices to mariners. The GSM modem uses a mobile network signal to keep iECDIS up to date anywhere with mobile signal, even downloading the most recent piracy warnings and weather forecasts. Designed and built to military specification, iECDIS is available for lease or purchase.

[www.martek-marine.com](http://www.martek-marine.com)



### Vessel Optimization Data

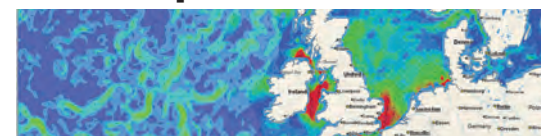

A vessel optimization application offering combined tidal and non-tidal (ocean) current data was launched for integrated vessel speed and route optimization. Developed by Tidetech, the application offers resolution of six nautical miles at 60-minute intervals in a six-day forecast. Tidetech managing director Penny Haire said this was the first time ships could access global tides and ocean currents in the same application. Haire said Tidetech currently uses Mercator as its front-line ocean current model, a six-day ocean forecast at five nautical mile resolution, forced by ECMWF weather data. In simulations for various northern European and eastern Asian shipping routes, Tidetech has been able to demonstrate significant projected time savings.

[www.tidetech.org](http://www.tidetech.org)

## Lilaas L01 Control



Full type approval has been granted to the new generation 'plug and play' L01 control lever, opening the way for widespread uptake of the integrated electronic shaft system technology Norwegian supplier Lilaas believes will change the ship control sector. The all-electric L01 has secured type approval from DNV covering International Association of Classification Societies E10 standards for control units, EN60945 standards for Marine Navigation Equipment, and the International Protection standard IP56 covering protection against access to hazardous parts, ingress of solid foreign objects and water.

The L01 can be used for Azimuth, single and double thruster/propulsion control. It features a distinctive integral display that can be customized to suit individual users, with all information available in one place. The all-electric configuration also means that the L01 requires a very shallow space beneath the lever. However, one of the L01's most compelling feature is its drop-in installation and the fact that force feedback is achieved without intermediary motors.

[www.lilaas.no](http://www.lilaas.no)

## Voyager Planning Station Adds AtoBviaC Distance Tables



AtoBviaC said that its BP Shipping Marine Distance Tables are now incorporated into the Voyager Planning Station solution. Routes are calculated by Master Mariners to provide accurate, reliable calculations taking into account issues such as traffic separation schemes and navigational restrictions. For the tenth year in succession, new WS flat rates have been calculated using round voyage distances taken from tables developed by AtoBviaC – the BP Shipping Marine Distance Tables.

[www.atobviaonline.com](http://www.atobviaonline.com)

## Northport Actisense Engine Monitoring Units

Northport Systems offers a new intelligent National Marine Electronic Association (NMEA)-compliant gateway, the Actisense Engine Monitoring Unit (EMU-1). Designed to digitize analog engine data, The EMU-1 gateway is an innovative, cost-effective, and easy-to-install solution that allows boaters to display and monitor the engines of their vessel on any NMEA 2000 displays. The Actisense EMU-1 gateway is capable of digitizing up to six parameters or gauge inputs in parallel, or four alarms, two tachometer and two auxiliary inputs. Each unit can be configured to meet the versatility of various engine makes and models.



[www.actisense.com](http://www.actisense.com)

## MarineNav's New Line of Displays



MarineNav Ltd. developed its Mariner Series for commercial vessels requiring dedicated single-input marine grade displays. Ideal for use with Engine Management, Advanced Vessel Monitoring, radar and ECDIS systems, the Mariner displays feature optically-bonded AR glass, 300-400 nits brightness, IP 65 water-resistance (front), and dedicated backlit front controls. All of MarineNav's displays are constructed from marine grade aluminum and come with a two-year warranty. Mariner Series displays are available in 15", 19", 21.5" and 24" sizes and offer a number of options including optional high-brightness panels, IP 65 water-resistance (rear), and projected-capacitive (P-CAP) touchscreen.

[www.marinenav.ca](http://www.marinenav.ca)

## Navis Joystick System for New Yacht



Navis Engineering will supply its JP4000 Joystick Control System to Drettmann Yachts for a 24m Explorer Series vessel under construction at Acico Yachts BV in Enkhuizen in the Netherlands. The yacht features unique electrical podded thrusters in both the stern azimuth and bow tunnels which reduce sound and vibration and the JP4000 adds control and flexibility when maneuvering or with the integrated autopilot at sea.

[www.navis.com](http://www.navis.com)

## L-3 SAM to Supply Electrical Package for DanTysk Wind Project

L-3 SAM Electronics won a contract for the supply and installation of the electrical system package on an accommodation platform being built in Kiel, Germany, by Nobiskrug of Rendsburg as part of the DanTysk offshore wind farm project jointly developed by Stadtwerke München (SWM) and Vattenfall. L-3 SAM Electronics' scope of supply for the 2,500-sq.-m. platform covers provision of low-voltage switchgear and uninterrupted power supplies inclusive of cabling, all internal communications, IT, entertainment amenities and advanced safety facilities consisting of an automated remote control and monitoring system with alarm functions. Other equipment includes navigational and general lighting systems, type-approved sea marking components, GMDSS communications and a radar system.

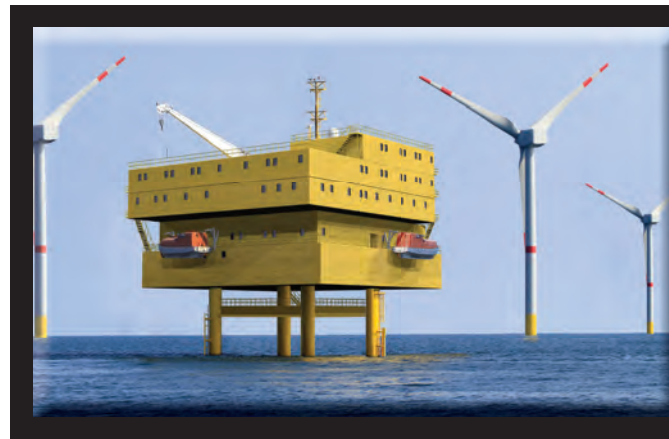

[www.vulkan.com](http://www.vulkan.com)

### Ship-to-Turbine Oil Change System

James Fisher Renewables conducted a trial of Ship-to-Turbine (STT), an oil change system designed to improve safety, efficiency and reduce down time in offshore wind turbine gearbox oil changes. The trial was performed on an offshore wind farm off the Norfolk coast where it reportedly was demonstrated the STT system helped to complete the entire evacuation, flushing and refill of the gear oil system in less than four hours total pumping time per turbine. The company believes that the Ship-to-Turbine method has the potential to revolutionize offshore oil change operations, while increasing the safety



of technicians, reducing the risk of pollution and significantly increasing operational efficiency.

[www.james-fisher.com](http://www.james-fisher.com)

### Hoffer Flow Measurement Systems



Hoffer Flow Controls received a contract from the U. S. Navy Sea Systems Command to supply fuel flow measurement systems as a part of the U.S. Navy's Energy Dashboard Program. Hoffer fuel measurement systems are currently incorporated into the "Energy Dashboard Proof-of-Concept System" aboard several of the US Navy DDG51 class ships. The new contract will expand the number of ships equipped. The "Energy Dashboard" uses an integrated condition assessment system, which ties into other shipboard computer software systems making sailors aware of how certain engineering plants line-up and the overall effects on fuel consumption rates. Sailors will now have access to instantaneous net fuel consumption rates.

[www.hofferflow.com](http://www.hofferflow.com)

### Phoenix Launches HDL-LED Series

Phoenix Products Company introduced the HDL-LED Series, designed to replace linear fluorescent fixtures. Using marine grade construction, conformal coated circuit boards and a potted driver, this fixture is designed to withstand the elements, the manufacturer said. The standard fixture is designed for continuous row mounting. It is designed for machine houses, engine rooms, mining equipment, conveyor lighting and various other demanding applications. The HDL-LED Series provides 30W, 60W and 90W configurations delivering 3,000, 6,000 and 9,000 lumens, respectively. The fixture features an AC or DC driver with a dimmable option.

[www.phoenixlighting.com](http://www.phoenixlighting.com)



### New Steering System

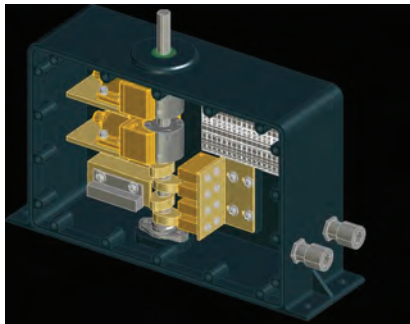

Rio Controls & Hydraulics (RCH) said it has developed a new steering system by modifying existing inductive sensors used in the oil and gas industry to reach a design that the company said will provide accurate and longer lasting sensor command and feedback signals. This technology aims to replace conventional devices such as potentiometers, as RCH claims its

system offers many advantages over traditional steering. Features include: Inductive Technology has no moving parts; These sensors are rated IP67; Using this new technology allows RCH to calibrate the entire steering system to include command sensors, feedback sensors, limit switches and rudder angle indication sensors in under 30 minutes.

[www.riomarineinc.com](http://www.riomarineinc.com)

### New Line of Safety Switches

The ABB Low Voltage Products division introduced a new line of heavy duty safety switches for commercial and industrial applications, meeting the necessary UL98, CSA and NEMA KS-1 standards for the most demanding service-entrance and motor-load applications. The 600V and 200kA rated switches use the same globally rated bodies as ABB's rotary-style switches. According to ABB, they are the first heavy duty switches in the industry to offer touch-safe visible blades and operating mechanisms that are fully

enclosed and protected from dirt and debris. The new ABB heavy duty safety switches range from 30 to 1,200 Amperes, and are available as fused and non-fused, with Types 1/12/3R/4X steel or stainless steel enclosures.



[www.abb.com](http://www.abb.com)

Holland America Line (HAL) said it will retrofit the VDR system of its entire fleet of 15 ships with the Interschalt VDR G4. "Re-player," VDR G4's online monitor, provides a detailed picture of the ship's position in real time on a chart and can transfer this playback to a notebook or a smartphone so that the captain can access an overview of the current situation at all times even from his cabin. Important information about radars, alarms, the positioning on the electronic chart, machine data from the conning display and helm data is available in real time. New features: the information automatically flows through the newly installed VDRs and INTERSCHALT's BLUETRACKER software solution via satellite communication, which means that in cases of emergency the crew no longer has to also worry about transmitting data but instead can take action and simultaneously receives support on account of the data, which is transmitted automatically, via email, SMS or to smartphones, etc.. This way, the onshore team can provide valuable assistance.



## HAL Retrofits VDRs on Fleet



[www.interschalt.de](http://www.interschalt.de)



[smm-hamburg.com](http://smm-hamburg.com)

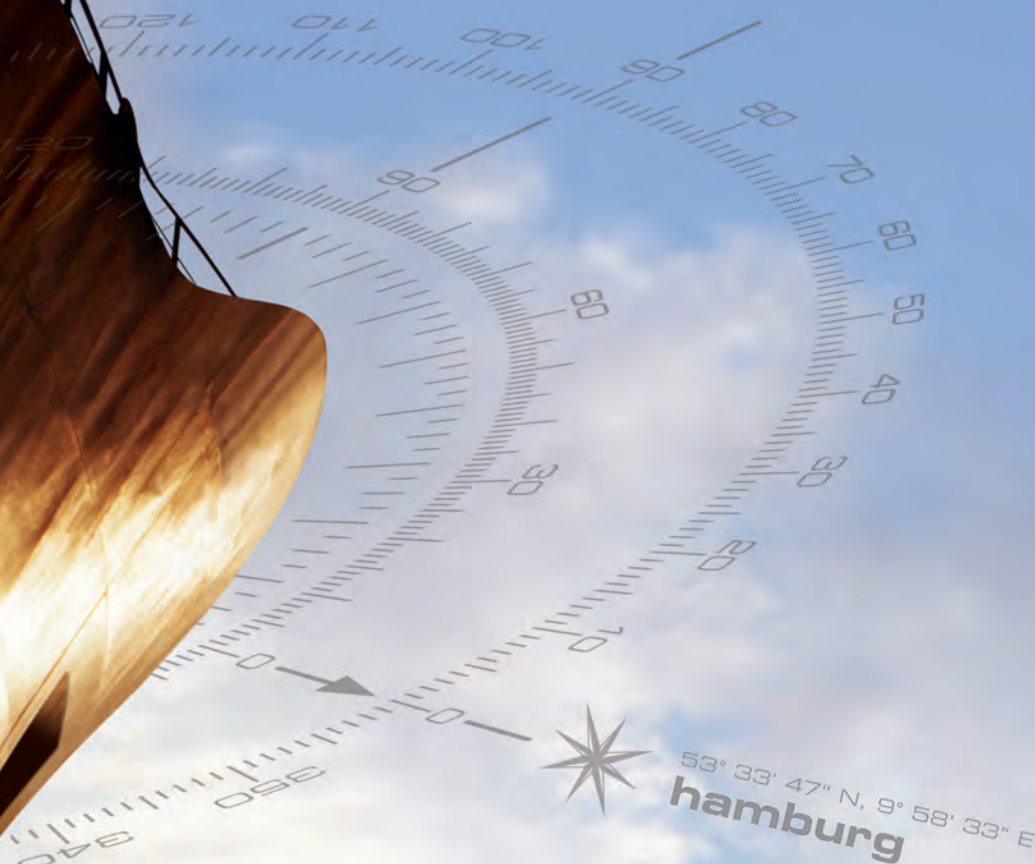

# keeping the course

9 - 12 september 2014

hamburg

the leading international  
maritime trade fair

buy your SMM ticket  
online – save 10%  
and waiting time at  
the cash desk

[smm-hamburg.com/visit](http://smm-hamburg.com/visit)

8 sept

finance day

9 sept

environmental protection day

10 sept

security and defence day

11 sept

offshore day

What impact does Offshore business have on the maritime industry?  
Meet the experts and get insights first!

12 sept

recruiting day



scan the QR code and view the trailer  
or visit [smm-hamburg.com/trailer](http://smm-hamburg.com/trailer)



Hamburg Messe



Ufi  
Approved  
Event



# MaritimeJobs.com

where employers and job seekers connect

The Maritime Industry's Leading Employment Website. For more information contact: Jean Vertucci at [vertucci@marinelink.com](mailto:vertucci@marinelink.com)



(206) 232-6041

[June@maritimerecruiters.com](mailto:June@maritimerecruiters.com)  
Established 1969

## Bouchard Transportation Co., Inc.

### Vessel Cook

#### Qualifications:

MMD endorsement Ordinary Seamen, TWIC, and Passport  
Cooking Experience 2 + years, preferably on Tugs

### Asst Engineer

#### Qualifications:

- Degree from Merchant Marine Academy or 3 year's experience working on tugs of at least 2,000 HP
- MMD DDE 1,000 to 4,000 HP
- STCW
- TWIC

### Tankerman AB/Cargo Mate

#### Qualifications:

- Minimum of a AB Tankerman PIC (BARGE)
- STCW
- TWIC

Send all resumes to  
[personnel@bouchardtransport.com](mailto:personnel@bouchardtransport.com)  
Or Fax to 631-390-4966



## BOSTON SHIP REPAIR

### Marine Estimator

#### SUMMARY

Prepare and administer accurate labor, material and subcontractor estimates for all proposals and growth work for the ship repair/drydocking industry.

- Complete estimates for assigned projects of medium size and complexity, either independently or as the lead estimator for the proposal team.
- Support proposal team by performing quantity survey and cost estimates for assigned portions of projects.
- Review, interpret, quantify, accurately estimate cost, and critically analyze the work described in the technical specification documents.
- Make reliable and accurate conclusions based on this knowledge in the most economical manner. Extended hours may be required to meet deadlines.
- Use accepted templates for the preparation of estimates and clarifications, analysis of bids, calculation of alternates, and other tasks.
- Solicit, collect and critically analyze subcontractor/vendor budgets, bids or quotations associated with assigned proposal. Provide comparison of cost to perform work in house versus utilization of subcontractors.
- Attend pre-bid ship checks on board ships and post-bid meetings with the customer.
- Prepare work schedules in Microsoft Project for submission with proposals.

#### COMPUTER EQUIPMENT AND SOFTWARE SKILLS NECESSARY

- Word, Excel, Microsoft Project and estimating software

#### EDUCATION and/or EXPERIENCE

Bachelor's degree from four-year college or university preferred and/or eight to ten years related experience and/or training; or equivalent combination of education and experience. Marine Engineering/Transportation experience is preferred.

"An Equal Opportunity Employer"

EEO Minorities/Women/Disabled/Veterans

Qualified candidates may apply via our website: [www.northeastship.com](http://www.northeastship.com)

Get essential maritime  
business news - direct  
from industry leaders

[www.maritimeprofessional.com](http://www.maritimeprofessional.com)



## IMPACT SYSTEM™

Interactive Media Performance and Campaign Tracking

Take control of your campaign-  
only from New Wave Media.

Give your online advertising real IMPACT- an  
exclusive tracking tool for online advertisers.

IMPACT platform displays  
data and traffic from:

Browsers-Platforms  
Desktop / Mobile  
Countries

Track banner ad exposure in  
real time, with an easy interface

Impressions / Clicks  
Click Through Rate  
Unique IPs

Access a complete report of your  
Eblast campaign's success.

Total Emails Sent  
Opened Emails  
Links Clicked

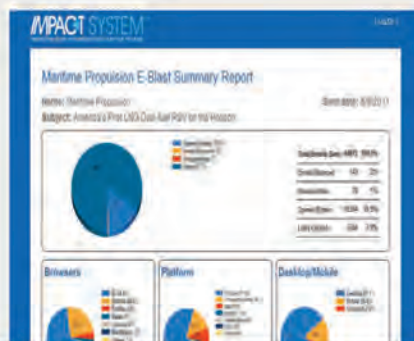

Available for all online/email ad programs, only from New Wave Media.  
For details, contact your rep or call our offices: (212) 477-6700



**NAVAL ARCHITECTURE**  
**CONCEPTUAL DESIGNS**  
**MARINE ENGINEERING**  
**PRODUCTION ENGINEERING**  
**LOFTING & NESTING**  
**TOOLING DESIGN**

**BOKSA**  
Marine Design

[BoksaMarineDesign.com](http://BoksaMarineDesign.com) 813.654.9800



**The Leader in Vibration Analysis**  
**Call Us Today at 251-232-7163**  
[www.bolandindustrial.com](http://www.bolandindustrial.com)

**C. R. CUSHING & Co., INC.**  
NAVAL ARCHITECTS • MARINE ENGINEERS • TRANSPORTATION CONSULTANTS

30 VESEY ST  
7TH FLOOR  
NEW YORK, NY  
10007

**SINCE 1968**

Ph: (212) 964-1180  
Fax: (212) 285-1334  
info@crcco.com  
www.crcco.com

**Established in 1854**



**GRANDALL**  
DRY DOCK ENGINEERS, INC.

- Consulting • Design • Inspection
- Railway and Floating Dry Docks
- Dry Dock Hardware and Equipment

Box 505804, Chelsea, MA 02150 (617) 884-8420 Fax: (617) 884-8466  
[www.crandalldrydock.com](http://www.crandalldrydock.com)



- Naval Architecture
- Structural Engineering
- Project Management

One Galleria Boulevard, Suite 907  
Metairie, Louisiana 70001  
Phone: 504.818.0377 Fax: 504.818.0447  
[www.downeyengineering.com](http://www.downeyengineering.com)



**GEORGE G. SHARP, INC.**

22 CORTLANDT STREET, NEW YORK, NY 10007  
TEL (212) 732-2800 FAX (212) 732-2809

WASHINGTON (703) 835-9997  
VIRGINIA BEACH (757) 499-4125  
SAN DIEGO (619) 425-4211

[www.ggsharp.com](http://www.ggsharp.com)  
MARINE SYSTEMS • ANALYSIS & DESIGN

Do your heavy-lifting with GHS!

- \* Multi-Body simulation of loading and unloading floating objects.
- \* Quickly append one or more geometry files to the existing model.
- \* Crane module for vessel-mounted cranes with multiple hooks.
- \* Complex salvage procedures
- \* Modeling of mooring systems

[www.ghsport.com/home/index.htm](http://www.ghsport.com/home/index.htm)



**Ship Stability and Strength Software**

GHS ..... Full-featured naval architect's system  
GHS Load Monitor (GLM) ..... Onboard configuration  
BHS ..... Basic hydrostatics and stability



**Creative Systems, Inc.**  
Creators of GHS™

P.O. Box 1910 Port Townsend, WA 98368 USA  
phone: (360) 385-6212 email: sales@ghsport.com  
[www.GHSport.com](http://www.GHSport.com)

For 42 years, the software that naval architects love.

SPECIALISTS IN THE DESIGN OF:

- OFFSHORE SUPPORT VESSELS
- TUGS AND TOWBOATS
- BARGES
- HIGH SPEED CRAFT
- NAVAL VESSELS
- CREWBOATS
- SPECIAL PURPOSE VESSELS
- YACHTS



DESIGN, CONSULTING, SURVEYING AND DRAFTING SERVICES



**GUARINO & COX, LLC**  
Naval Architects, Marine Designers and Consultants  
19399 Helenburg Road Suite 203 Covington, LA 70433  
Tel: (985) 871-9997 Fax: (985) 871-9927 [www.guarino-cox.com](http://www.guarino-cox.com)



**ABS Approved Ambient Environmental Testing**  
Climate, Lighting, Noise & Vibration

1 Galleria Blvd. Ste 109 Metairie, LA 70001  
Phone (504) 818-0377 x 33 Fax (504) 818-0447  
[www.hab-cert.com](http://www.hab-cert.com)

**HEGER DRY DOCK, INC.**

531 Concord Street, Holliston, MA 01746

Engineering for all types of dry docks

- Design
- Docking Calculations
- Certifications
- Engineer/Diver
- Inspections
- U.S. Navy 1625D FCR's

Phone: (508) 429-1800 Fax: (508) 429-1811  
[www.hegerdrydock.com](http://www.hegerdrydock.com)

**Deckplate experience behind every design.**



Introducing our latest design:  
JMS Coastal Research Vessel Series



**JMS**  
NAVAL ARCHITECTS  
The sea-going naval architects.

Naval Architecture  
Marine Engineering  
Shipyard Engineering Support  
Marine Surveys

860.536.0009  
[www.JMSnet.com](http://www.JMSnet.com)

**GILBERT ASSOCIATES, INC.**  
Naval Architects and Marine Engineers



350 Lincoln St., Suite 2501  
Hingham, MA 02043  
T: (781) 740-8193 • F: (781) 740-8197  
E-mail: [inbox@jwgainc.com](mailto:inbox@jwgainc.com)  
[www.jwgainc.com](http://www.jwgainc.com)

**MASSACHUSETTS BAY TRANSPORTATION AUTHORITY MATERIALS MANAGEMENT DIRECTORATE**

**NOTICE TO OFFERORS**

The Massachusetts Bay Transportation Authority will be issuing a Request for Sealed Proposals on a Competitive Negotiated Basis for the Design/Build of Two (2) 26 Meter Subchapter "T" Passenger Only High Speed Ferries to service commuter routes in Boston Harbor and adjacent waters. Shipyard services to also include Capital Spares, Manuals and Drawings, Operator Training and Maintenance Training in accordance with Authority specifications.

This project will be federally funded. The Contractor will be required to comply with all applicable Equal Employment Opportunity Laws and Regulations, DBE Laws and Regulations, U.S. Domestic Content and other regulations as required. All Offerors will be required to certify that they are not on the Comptroller General's List of Ineligible Contractors.

Proposal documents, technical specifications, and other pertinent information will be available in May 2014 on the Authority's Materials Procurement Advertisement System located at [www.mbta.com](http://www.mbta.com). This system gives all vendors the opportunity to receive automated email alerts and download an electronic copy of the Request for Proposals and any addenda as soon as they become available. Interested firms are invited to register at <http://www.mbta.com/BCRegister>. A pre-bid conference is planned for June 2014. Please refer to the Authority's website and the proposal documents for more information.

The Authority reserves the right to reject any or all proposal(s), to waive minor irregularities, or to advertise for new offers, as deemed in the best interest of the Authority.

Richard A. Davey  
Secretary and Chief  
Executive Officer, MassDOT

Beverly A. Scott, Ph.D.  
MBTA General Manager and  
MassDOT Rail & Transit Administrator



Fast underwater repair and maintenance services



**HYDREX**  
UNDERWATER TECHNOLOGY

Hydrex LLC - Tampa, U.S.A.  
Phone: +1 727 443 3900 (24/7)  
E-mail: info@hydrex.us

[www.hydrex.us](http://www.hydrex.us)

**M.A.C.E.**

Marine Industry

FT. LAUDERDALE - USA - WORLDWIDE  
PHONE: (954) 563-7071 FAX: (954) 568-6598

- N.D.T. Services
- Vibration - noise - structural/modal analysis
- Field balancing, Laser Alignment
- Torque - torsional vibration analysis
- IR - Thermography inspection
- Emission tests, Engine Performance tests

**MSCorp**

Marine Systems Corporation

70 Fargo Street  
Boston, Ma 02210  
p: 617-542-3345  
f: 617-542-2461  
[www.msccorp.net](http://www.msccorp.net)

Excellence in Engineering and Design  
Government and Commercial Support  
Since 1973

Marine Engineering  
Naval Architecture  
Logistic Support  
Maintenance Planning

**LAY, PITMAN & ASSOCIATES, INC.**  
NAVAL ARCHITECTS

- Naval Architecture Services
- Marine Engineering
- Design Services
- Construction Administration
- Regulatory Liaison
- Inspections and Surveys

13891 Atlantic Blvd., Jacksonville, FL 32225  
(904) 221-7447 • [www.laypitman.com](http://www.laypitman.com)



**MARITIME REPORTER**  
AND  
ENGINEERING NEWS

Leading the way for over 75 Years

[www.marinelink.com](http://www.marinelink.com)

**Tired of nautical reproductions**



Maritifacts has only **authentic marine collectibles** rescued from scrapped ships: navigation lamps, sextants, clocks, bells, barometers, flags, binnacles, telegraphs, portholes & more. Current Brochure - \$1.00.

[www.maritifacts.com](http://www.maritifacts.com) / [maritifacts@aol.com](mailto:maritifacts@aol.com)

**MARTIFACTS, INC.**  
P.O. Box 350190 Jacksonville, FL 32235-0190  
Phone/Fax: (904) 645-0150

CG State Pilotage License Insurance/ Mariners' Disability Insurance  
For Quotes on License Insurance or Mariners' Disability Insurance  
See our web site: [marinelicenseinsurance.com](http://marinelicenseinsurance.com)

**R.J. MELLUSI & CO.**  
29 Broadway, Suite 2311  
New York, N.Y. 10006  
Ph: (212) 962-1590  
Fx: (212) 385-0920  
[Rjmellusi@sealawyers.com](mailto:Rjmellusi@sealawyers.com)



**5000' PERMITTED BARGE FLEET**  
West Bank of Michoud Canal at New Orleans  
off Gulf Intracoastal Waterway east of Inner  
Harbor Locks, inside surge protection barrier.  
Contact Paul Ramoni  
504-813-7787 • [peramoni@gmail.com](mailto:peramoni@gmail.com)



**Custom Sea Water Intake Filters  
Strainers and Screens**

Call us for your free estimate  
**866-265-0502**

**Yankee Wire Cloth Products, Inc.**  
Since 1963

221 W. Main St.,  
West Lafayette OH 43845  
Fax: 740-545-6323

[www.maritimefilter.com](http://www.maritimefilter.com)

**SIMPLE. RUGGED. RELIABLE.**

**KIENE Cylinder Pressure Indicators  
for measuring diesel engine  
firing pressures...**



- Easy to use - simple and reliable
- Reduce maintenance costs.
- Improve engine availability.
- Use to balance cylinders.
- Pinpoint engine Problems.
- Optimize fuel consumption.
- Fits any standard indicator valve.
- Recommended and used by major engine builders
- Minimal investment to monitor engine condition.

**Contact us now for more information.**

**KIENE** DIESEL ACCESSORIES, INC. Phone: 1-800-264-5950  
Fax: 630-543-5953  
[www.kienediesel.com](http://www.kienediesel.com)  
E-mail: [info@kienediesel.com](mailto:info@kienediesel.com)

**USCG  
License Software**

Affordable - Merchant Marine Exam Training  
<http://hawsepipe.net>

Freelance Software  
39 Peckham Place  
Bristol, RI 02809  
(401) 556-1955 - [sales@hawsepipe.net](mailto:sales@hawsepipe.net)

**Muldoon Marine Services**  
COMMERCIAL DIVING • MARINE SERVICES

**REDUCE FUEL CONSUMPTION**  
Propeller Polishing, Hull Cleaning

**UWILD SURVEYS**  
Approved By All Major Class Societies

**IN-WATER REPAIRS**

24-Hour: (562) 432 5670  
Long Beach, CA  
[www.muldoonmarine.com](http://www.muldoonmarine.com)







**Subsalve USA**

America's largest manufacturer of Underwater Lift Bags available from 25 lbs. to 50 tons and Water Load Test Bags to 50 tons. Large inventory available. IMCA compliant. ABS Approved.



P.O. Box 2030, North Kingstown, RI 02852, USA  
Tel: +1 401 884 8801 Fax: +1 401 884 8868  
[www.subsalve.com](http://www.subsalve.com) [richard@subsalve.com](mailto:richard@subsalve.com)

**WE ARE THE STANDARD IN INDUSTRIAL DEHUMIDIFICATION.**



Tel: (757) 873-6800 • Fx: (757) 873-3632  
Toll Free: 1 855-873-6800  
[www.ebacusa.com](http://www.ebacusa.com)  
[sales@ebacusa.com](mailto:sales@ebacusa.com)  
700 Thimble Shoals Blvd. Ste 109  
Newport News, VA 23606



**SINCE 1980 THE NAME TO TRUST FOR EQUIPMENT AT SEA**

**SALES • SERVICE • MARINE ENGINEERING**

MARINE CRANES  
BOOM  
SKIMMERS  
PUMPS  
REFUELING SYSTEMS



*Davitt Sales Inc. Tel: 914-962-4544 • Fx: 914-962-5418*  
[info@davittsalesinc.com](mailto:info@davittsalesinc.com)  
[WWW.DAVITSALESINC.COM](http://WWW.DAVITSALESINC.COM)

# MARITIME PROPULSION

Maritime Propulsion is the largest online database for marine power & propulsion equipment - the fastest way to find engine reports, specs, suppliers, and exclusive articles on industry developments.



[www.maritimepropulsion.com](http://www.maritimepropulsion.com)

## REVOLUTIONARY VIBRATION AND BEARING ANALYSIS



**LEONOVA**  
DIAMOND

Leonova Diamond is the latest proof of our commitment to developing first class condition monitoring products for more profitable maintenance. Use SPM HD for accurate rolling element bearing analysis. Reduce data collection time with tri-axial vibration measurements. Add balancing, laser alignment, orbit analysis and much more, all in a rugged and lightweight instrument.

For a total Condition Monitoring package, contact us today!

Tel. 1-800-505-5636  
[leonovabyspm.com](http://leonovabyspm.com)  
[spminstrument.com](http://spminstrument.com)



# MR

## Vessels for Sale/Barges for Rent

[www.MaritimeEquipment.com](http://www.MaritimeEquipment.com)



**emr**

We buy barges, ships, and other marine vessels and structures for scrap. We adhere to the highest ES&H standards. Serving the rivers and coasts of the U.S.

AMELIA • BROWNSVILLE  
HOUSTON • MOBILE  
MORGAN CITY • NEW ORLEANS  
[us.emrgroup.com](http://us.emrgroup.com)  
CALL 800 - GO SCRAP

**CENTRAL BOAT RENTALS, INC.**  
Morgan City, LA

Ocean Barges: 180x54x12    260x72x16  
Tank Barges: 10K & 30K bbl Double Skin  
Ocean Towing                      Barge Fleeting  
Shipyard Services

(985) 384-8200                      [centralboat.com](http://centralboat.com)



**Maritime Global News** for iPhone and Android



**FREE APP**    SCAN THE CODE TO DOWNLOAD



**ZIDELL MARINE CORPORATION**

*Specializing In Barges*

- ◆ Single or Double Hull, Inland or Ocean-Going
- ◆ Design, Construction & Modification
- ◆ Chartering & Sales

Ask for Bill Gobel  
503-228-8691    1-800-547-9259  
3121 SW Moody Avenue, Portland, Oregon 97239

# ADVERTISER INDEX

GET FREE INFORMATION ONLINE at: [www.maritimeequipment.com/mr](http://www.maritimeequipment.com/mr)

| Page#  | Advertiser                       | Website  | Phone #                  | Page# | Advertiser                            | Website  | Phone #                   |
|--------|----------------------------------|--|--------------------------|-------|---------------------------------------|--|---------------------------|
| 51     | ABS                              | <a href="http://www.eagle.org">www.eagle.org</a>   | (281) 877-5861           | 15,35 | Kidde-Ferwal, Inc                     | <a href="http://www.kiddmarine.com">www.kiddmarine.com</a>                               | (508) 881-2000            |
| 37, 47 | Air Products AS                  | <a href="http://www.airproducts.no">www.airproducts.no</a>                                     | Please visit our website | 13    | Louisiana Cat                         | <a href="http://www.louisianacat.com">www.louisianacat.com</a>                           | (866) 843-7440            |
| 33     | American Vulkan                  | <a href="http://www.vulkan.com">www.vulkan.com</a>   | (863) 324-2424           | 5,37  | Man Diesel & Turbo                    | <a href="http://www.mandieselturbo.com">www.mandieselturbo.com</a>                       | Please visit our website  |
| 52     | Anchor Maine & Supply, Inc       | <a href="http://www.anchormarinehouston.com">www.anchormarinehouston.com</a>                   | (713) 644-1183           | 37    | Marine Learning Systems               | <a href="http://www.MarineLS.com">www.MarineLS.com</a>                                   | (855) E-MARINE (362-7463) |
| 53     | ATC King Engineering             | <a href="http://www.king-gage.com">www.king-gage.com</a>                                       | (304) 387-1200           | 52    | Maritime Associates                   | <a href="http://www.marinesigns.com">www.marinesigns.com</a>                             | 775-832-2422              |
| 50     | BMT Fleet Technology             | <a href="http://www.fleetech.com">www.fleetech.com</a>   | (613) 592-2830           | 17    | Maritime Professional Training        | <a href="http://www.mptusa.com">www.mptusa.com</a>                                       | (954) 525-1014            |
| 43     | Brunvoll A/S                     | <a href="http://www.brunvoll.no">www.brunvoll.no</a>   | 47 712 19600             | 50    | Massachusetts Maritime Academy        | <a href="http://www.maritime.edu/cmt">www.maritime.edu/cmt</a>                           | (508) 830-5005            |
| 9      | Citgo Petroleum-Clarion          | <a href="http://www.clarionenvirosafety.com">www.clarionenvirosafety.com</a>                   | 1-855-MY-CLARION         | C3    | McAllister Towing                     | <a href="http://www.McAllisterTowing.com">www.McAllisterTowing.com</a>                   | (212) 269-3200            |
| 25     | Click Bond Inc                   | <a href="http://www.clickbond.com">www.clickbond.com</a>                                       | (775) 885-8000           | 15    | Motor Services Hugo Stamp, Inc.       | <a href="http://www.mshs.com">www.mshs.com</a>   | (954) 763-3660            |
| 47     | Coastal Marine Equipment, Inc.   | <a href="http://www.coastalmarineequipment.com">www.coastalmarineequipment.com</a>             | (228) 832-7655           | 50    | NABRICO Marine Products               | <a href="http://www.nabrico-marine.com">www.nabrico-marine.com</a>                       | (615) 442-1300            |
| 11, 33 | Damen Shipyards Group            | <a href="http://www.damen.com/markets/crane-barge">www.damen.com/markets/crane-barge</a>       | 31 (0) 183 63 9327       | 45    | Omnithruster                          | <a href="http://www.omnithruster.com">www.omnithruster.com</a>                           | (330) 963-6310            |
| 39     | David Clark Company              | <a href="http://www.davidclark.com">www.davidclark.com</a>                                     | (800) 298-6235           | 28    | Patterson Company                     | <a href="http://www.pattersonmfg.com">www.pattersonmfg.com</a>                           | (800) 322-2018            |
| 51     | DeFelsko                         | <a href="http://www.defelsko.com">www.defelsko.com</a>   | (315) 393-4450           | 33    | R.W. Fernstrum                        | <a href="http://www.fernstrum.com">www.fernstrum.com</a>                                 | (906) 863-5553            |
| 45     | Engines, Inc.                    | <a href="http://www.enginespower.com">www.enginespower.com</a>                                 | (870) 268-3799           | 29    | RSC Bio Solutions                     | <a href="http://www.rscbio.com">www.rscbio.com</a>                                       | (800) 661-3558            |
| 3      | ExxonMobil                       | <a href="http://www.exxonmobil.com/mobildelvacmarine">www.exxonmobil.com/mobildelvacmarine</a> | Please visit our website | 29    | Saab Transponder Tech AB              | <a href="http://www.saabgroup.com/transpondertech">www.saabgroup.com/transpondertech</a> | Please visit our website  |
| 31     | Fisher Maritime Consulting Group | <a href="http://www.fishermaritime.com">www.fishermaritime.com</a>                             | (800) 732-3476           | 1     | Scania USA                            | <a href="http://www.scaniausa.com">www.scaniausa.com</a>                                 | (908) 964-0700            |
| 28     | Floscan                          | <a href="http://www.floscan.com">www.floscan.com</a>   | (206) 524-6625           | 47    | Schaefer Ventilation                  | <a href="http://www.schaeferfan.com">www.schaeferfan.com</a>                             | (800) 779-3267            |
| 7      | Furuno USA, Inc.                 | <a href="http://www.furunousa.com">www.furunousa.com</a>                                       | Please visit our website | 58    | SMM 2014                              | <a href="http://www.smm-hamburg.com/trailer">www.smm-hamburg.com/trailer</a>             | Please visit us online    |
| 47     | Helkama Bica Oy                  | <a href="http://www.helkamabica.com">www.helkamabica.com</a>                                   | 358 2 410 8700           | 20    | Sohre Turbomachinery, Inc.            | <a href="http://www.sohreturbo.com">www.sohreturbo.com</a>                               | (413) 267-0590            |
| 27, 35 | Hempel                           | <a href="http://www.hempaguard.hempel.com">www.hempaguard.hempel.com</a>                       | 45 45 88 3800/45273676   | 53    | Superior Lidgerwood Mundy Corporation | <a href="http://www.lidgerwood.com">www.lidgerwood.com</a>                               | (715) 394-4444            |
| 46     | Holdtight Solutions              | <a href="http://www.holdtight.com">www.holdtight.com</a>                                       | (800) 319-8802           | 37    | TEUFELBERGER Fiber Rope Corp.         | <a href="http://www.teufelberger.com">www.teufelberger.com</a>                           | (800) 333-6679            |
| 19     | Inmarsat                         | <a href="http://www.inmarsat.com">www.inmarsat.com</a>   | Please visit us online   | C2    | Trans Marine Propulsion Systems, Inc. | <a href="http://www.transmarine.org">www.transmarine.org</a>                             | (866) 833-9102            |
| 41     | Inventory Locator Service, LLC   | <a href="http://www.ILSmarine.com">www.ILSmarine.com</a>                                       | (901) 794-5000           | 35    | Transas Technologies Ltd              | <a href="http://www.transas.com">www.transas.com</a>                                     | 46 31 769 5600            |
| 21     | Japan Radio Company              | <a href="http://www.jrcamerica.com">www.jrcamerica.com</a>                                     | (205) 654-5644           | 23    | Ward's Marine Electric                | <a href="http://www.wardsmarine.com">www.wardsmarine.com</a>                             | (800) 545-9273            |
| C4     | Karl Senner, Inc.                | <a href="http://www.karlseinner.com">www.karlseinner.com</a>                                   | (504) 469-4000           | 41    | Wilhelmsen Ships Service              | <a href="http://www.wilhelmsen.com/shipsservice">www.wilhelmsen.com/shipsservice</a>     | Please visit our website  |

The listings above are an editorial service provided for the convenience of our readers. If you are an advertiser and would like to update or modify any of the above information, please contact: [productionmanager@marinelink.com](mailto:productionmanager@marinelink.com)

There's no business like

**TOW**

business

with McAllister playing the leading role



In 1864, James McAllister arrived in New York Harbor and launched the family business with 2 sail lighters. Today, as the fifth generation of the McAllister family continues the tradition of providing unsurpassed service to the maritime community, McAllister Towing has grown to a fleet of over 75 tugboats in 12 ports covering the US East Coast.

In honor of our 150th, as well as Maritime Reporter's 75th, Anniversary we are reprising some of our historic advertisements.

[www.mcallistertowing.com](http://www.mcallistertowing.com)

PROPELLING



EXCELLENCE

### Benefits:

- Steerprop units are designed for 15 years between overhauls, two-three times that of other options.
- Steerprop steel-fabricated housings are more rigid and impact-resistant than cast housings, and allow for faster deliveries.
- Steerprop HJ3 Nozzle provides an 8-12% increase in bollard pull, and 10-15% increase in maximum efficiency compared to standard nozzles.
- Steerprop units are all backed by Karl Senner, LLC Parts and Service.
- Steerprop utilizes either triple or quadruple ring-type seals with oil condition monitoring.
- Hull designed to fully utilize 360° vectored thrust.
- Mounting cans above the waterline for convenient serviceability.
- Shallow draft accommodations.
- PTO/PTI options available.

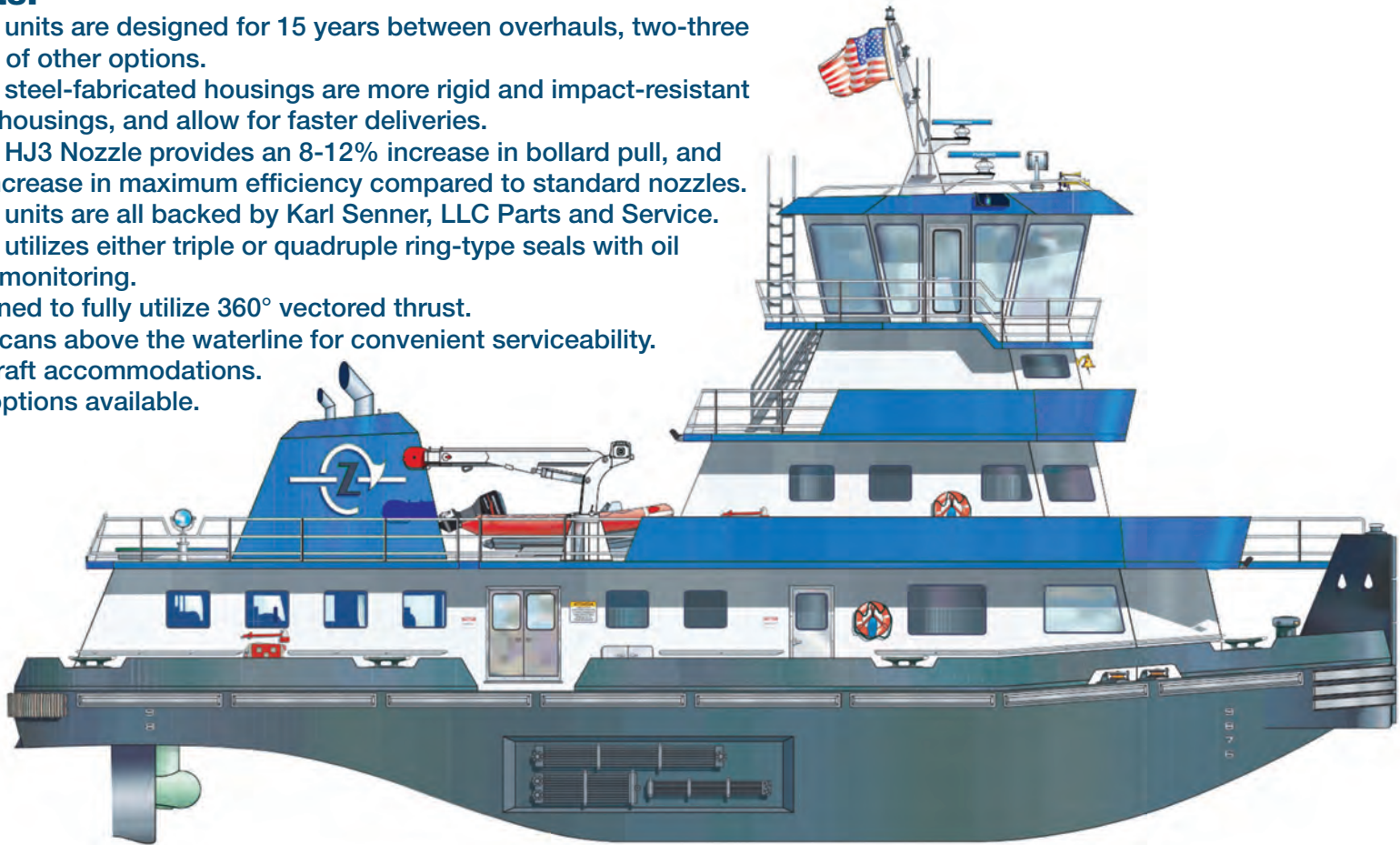

*This is an example of an Inland Pushboat designed specifically for utilizing Steerprop Zdrive Propulsion. Karl Senner, LLC has performed extensive studies together with experienced operators of Zdrive Pushboats, as well as vessel design groups to develop a concept built around Steerprop Zdrives. This rendering is provided by CT Marine, similar designs by CTM are available from 2,000-6,000 BHP.*



**PLEASE CONTACT US FOR MORE INFORMATION**

**GULF COAST**  
Karl Senner, LLC.  
25 W. Third St.  
Kenner, LA 70062  
Phone: (504) 469-4000

**E-MAIL US**  
[Service@karlsenner.com](mailto:Service@karlsenner.com)  
[Sales@karlsenner.com](mailto:Sales@karlsenner.com)  
[Parts@karlsenner.com](mailto:Parts@karlsenner.com)

**WWW.KARLSENNER.COM**