

December 2014

MARITIME REPORTER AND ENGINEERING NEWS

MARINELINK.COM

Great Ships of 2014

NASSCO

Balancing Commercial, Navy Work

LNG as Fuel

Regulators Struggle to Keep Pace

Offshore Ports

The Benefits to the U.S. & Africa

Waste Recycling Ship

New Concept from a Familiar Name



ENVIRONMENTAL SAFETY FACT:

51 TRILLION GALLONS OF
WATER COULD BE CONTAMINATED
BY LUBRICANTS EACH YEAR.

EQUAL TO THE AMOUNT OF WATER
THE UNITED STATES USES IN



**ENVIRONMENTAL
SAFETY SOLUTIONS.**

To help prevent pollution of sensitive marine environments, a new Vessel General Permit (VGP) has been introduced. Using Clarion® Lubricants can help you meet the 2013 VGP regulations. With zinc-free, ashless additives and readily biodegradable formulations, our full line of lubricants provide confident protection for your operation. And our waters.

Learn more about our safe and effective lubricant solutions at ClarionEnviroSafety.com.

 **clarion.**
LUBRICANTS





**SPANNING THE GLOBE
WITH OVER 60 YEARS OF
SHIPBUILDING EXCELLENCE**



VT Halter Marine

A company of VT Systems



VT Halter Marine

A company of VT Systems

Ship Repair & Drydock Services

Foreign Broker Inquiries Welcome

900 Bayou Casotte Parkway Pascagoula, MS 39581 USA Tel: 228-696-6888 Visit our website at www.vthaltermarine.com or email sales@vthm.com

CONTENTS

PIETER SCHELTE



HARVEY ENERGY

NUMBER 12 / VOLUME 76 / DECEMBER 2014



ZEROCAT 120



AL KOUT



CSCL GLOBE



TOP CORAL DO ATLANTICO



SIEM MOXIE



GAS STAR



AL KOUT

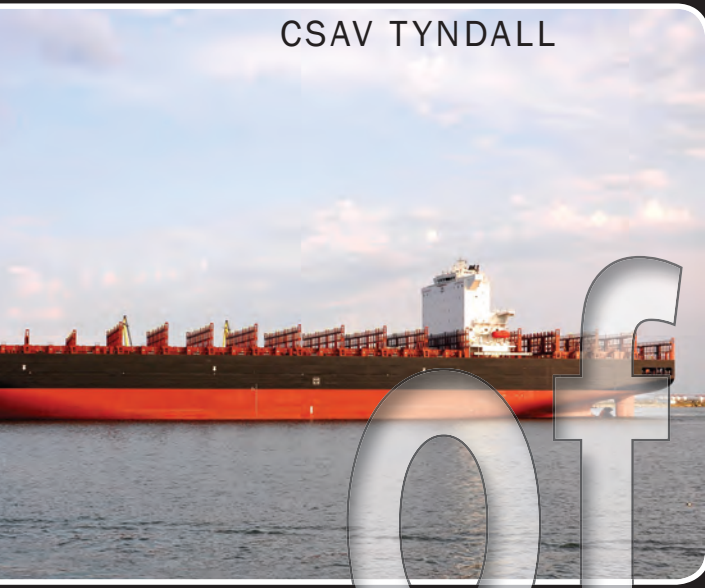

CSAV TYNDALL

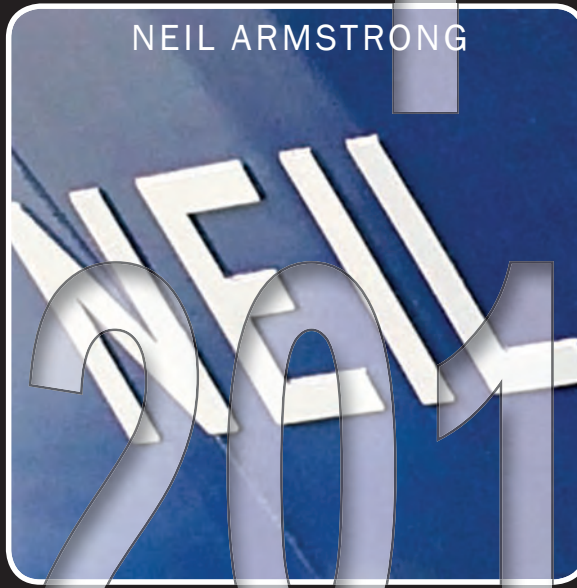

NEIL ARMSTRONG



SEMPER FI



QUANTUM OF THE SEAS



HARVEST LEADER

HÖEGH AUTOLINERS



LINDA OLDENDORFF

Experience the Power of **One**



Hardware

TracPhone® VIP-series – award-winning SATCOM systems with built-in network management

Content Delivery

IP-MobileCast – a unique multicasting service that delivers content directly to your vessel

DELIVERED BY
KVH
 IP-MobileCast™

Only **one** company delivers **one** integrated **end-to-end** solution.

Connectivity

mini-VSAT Broadband – the No. 1 maritime VSAT network offers global coverage



Rich Content

Licensed news, sports, movies, TV, and music, *plus* training, weather, and charts, delivered to onboard devices



Connectivity *and* Content

Giving **you** the power to deliver the bandwidth your operations demand, keep your crew happy, and manage your budget... all at the same time.

Learn more about industry-leading VSAT, training, weather, charts, and entertainment at:

kvh.com/powerofone



Contents



MARITIME REPORTER AND ENGINEERING NEWS

MARINELINK.COM

HQ
118 E. 25th St., 2nd Floor
New York, NY 10010 USA
Tel +1 212 477 6700
Fax +1 212 254 6271
www.marinelink.com

FL Office
215 NW 3rd St
Boynton Beach, FL 33435-4009
Tel +1 561 732 4368
Fax +1 561 732 6984

Publishers
John E. O'Malley
John C. O'Malley
jomalley@marinelink.com

Associate Publisher/Editorial Director
Greg Trauthwein trauthwein@marinelink.com

Vice President, Sales
Rob Howard howard@marinelink.com

Web Editor
Eric Haun haun@marinelink.com

Web Contributor
Michelle Howard howard@marinelink.com

Editorial
George Backwell - Thailand;
Joseph Fonseca - India
Claudio Paschoa - Brazil
Peter Pospiech - Germany

Production
Irina Tabakina tabakina@marinelink.com
Nicole Ventimiglia nicole@marinelink.com

Corporate Staff
Mark O'Malley, Public Relations
Esther Rothenberger, Accounting
Gabby DelGatto, Office Manager

Information Technology
Vladimir Bibik
Emin Tule
Christopher Lee

Subscription
Kathleen Hickey k.hickey@marinelink.com

Sales
Lucia Annunziata annunziata@marinelink.com
+1 212 477 6700
Terry Breese breese@marinelink.com
+1 561 732 1185
Frank Covella covella@marinelink.com
+1 561 732 1659
Mitch Engel engel@marinelink.com
+1 561 732 0312
Mike Kozlowski kozlowski@marinelink.com
+1 561 733 2477
Dawn Trauthwein dtrauthwein@marinelink.com
+1 631 472 2715
Jean Vertucci vertucci@marinelink.com
+1 212 477 6700

International Sales
Scandinavia
Roland Persson roland@orn.nu
Orn Marketing AB, Box 184, S-271 24
Ystad, Sweden
t: +46 411-184 00 f: +46 411 105 31

Western Europe
Uwe Riemeyer riemeyer@intermediapartners.de
t: +49 202 27169 0 f: +49 202 27169 20

United Kingdom
Paul Barrett ieaco@aol.com
Hallmark House, 25 Downham Road, Ramsden
Health, Essex CM11 1PU UK
t: +44 1268 711560 m: +44 7778 357722
f: +44 1268 711567

Japan
Katsuhiko Ishii amskatsu@dream.com
Ace Media Service Inc., 12-6, 4-chome, Nishiike,
Adachi-ku, Tokyo 121, Japan
t: +81 3 5691 3335 f: +81 3 5691 3336

Korea
Jo, Young Sang biscom@biscom.co.kr
Business Communications Inc., Rm 1232,
Gwanghwamoon Official Bldg., 163,
1-Ga, Shinmoon-Ro, Jongro-Gu,
Seoul, Korea 110-999
t: +82 2 739 7840 f: +82 2 732 3662

Classified Sales t: (212) 477-6700



Business Publications Audit
of Circulation, Inc.

THE COVER

Al Kout, a crude oil tanker built by Daewoo Shipbuilding & Marine Engineering (DSME) for KOTC of Kuwait, is one of seventeen Great Ships of 2014.

Read more starting on page 38.

Cover Image: DSME

Great Ships 2014

Big. Green.

Those two words aptly summarize this grouping of seventeen Great Ships of 2014.

By Greg Trauthwein, Claudio Paschoa,
Peter Pospiech & Kathleen Gleaves

News, Analysis, Columns & Departments

Editorial	6
MaritimeProfessional.com	8
News & Analysis	10
They Said It	14
Government Update	16
Eye on Design	18
Legal Beat	20
People & Companies	68
2015 Editorial Calendar	70
Products	71
Buyer's Guide	74
Classified	75
Advertiser's Index	80

38

24

NASSCO Builds

General Dynamics NASSCO has become the face of U.S. shipbuilding, boasting an enviable commercial and military orderbook.

By Greg Trauthwein

62

Roundtable Marine Lubricants

On January 1, 2015, strict sulfur emission rules in ECA zones enter force. The change in fuel will also impact the engine lubricants ship owners should consider.

By Greg Trauthwein

58

Offshore Ports

The benefits of Offshore Ports in regards to safety and efficiency is undeniable.

By Marco Pluijm



DMWMARINEGROUP

marine cranes



dock mount



fishing



aqua culture

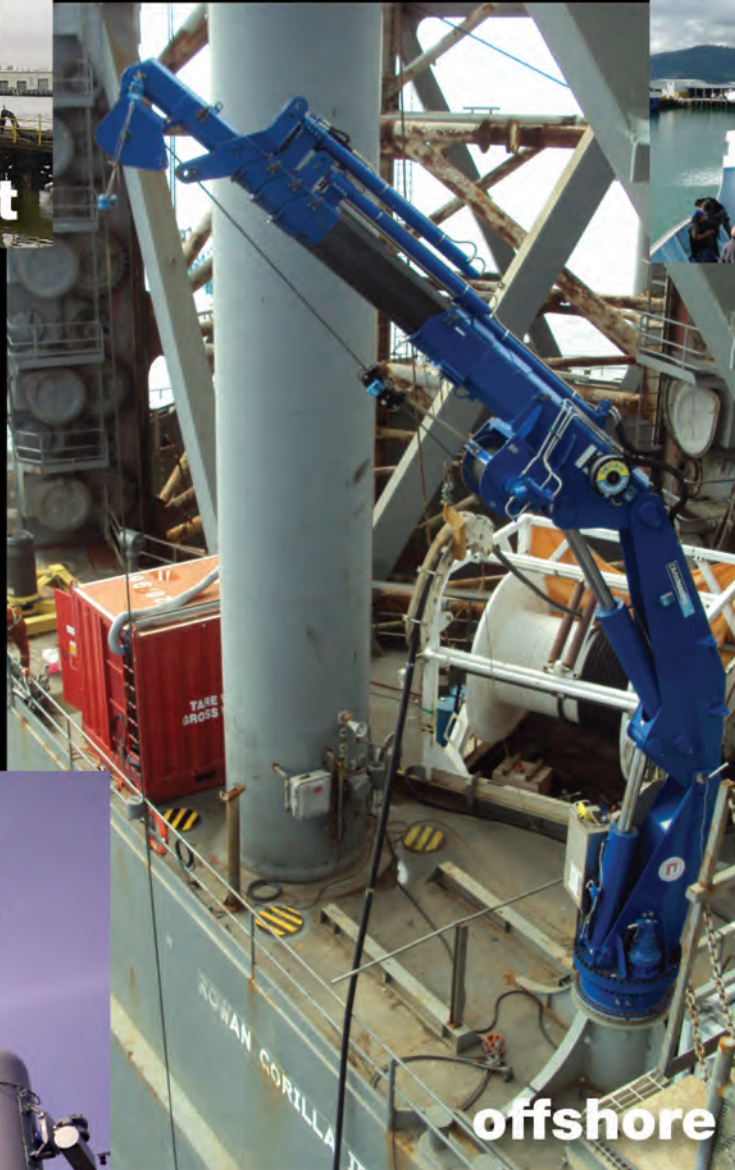

offshore



workboat



military

www.dmwmarinegroup.com

610.827.2032

Great Ships 2014 ... Big. Green.



GREG TRAUTHWEIN, EDITOR & ASSOCIATE PUBLISHER

As we close the chapter on 2014 and *Maritime Reporter & Engineering News'* 75th anniversary, I would like to start by offering a sincere 'thank you' to our subscribers, our advertisers and our "75th Anniversary sponsors" (see page 37) for your continued interest and support.

While this industry has changed mightily since 1939, maritime today remains the most efficient, cost-effective and environmentally benign means to move large quantities of goods from 'point A' to 'point B' around the globe. As many of you know well, this industry has been in the cross hairs of legislators globally and locally, with vigorous attention to the size and shape commercial ships and boats' emissions to the environment. While it is impossible to predict the future with a great deal of accuracy, I think it safe to say that the amount and level of legislative mandate in regards to this industry's carbon footprint is going nowhere but up, and quality, long-term players on the vessel owner, building, design and supply side need to find the opportunity in change to survive.

A big change coming is of course strict new regulation regarding the level of sulfur emissions from your vessels in the world's growing ECA zones, an environmental initiative that will have real impact on your bottom line. As many of you already know, changing fuel is not as simple as it sounds, as there are resulting consequences throughout your power system, particularly in the selection of marine lubrication and the potential for deposit build-up and cold corrosion. To answer some of your questions we've conducted a Marine Lubrication Roundtable with executives from several leading oil companies, starting on page 62.

This is our traditional Great Ships edition, and the 17 Great Ships in this year's field are an impressive lot. (Actually, you could count 18 ships if you consider the "Great Concept" Waste Recycling Ship concept from a group lead by **Dirk Lindenau** found on page 56.) In an evolving trend, ships continue to get larger, as size delivers an economy of scale and operation. This increase in size – including the mammoth Pieter Schelte on page 42 and the 19,000 TEU CSCL Globe on page 44 – is made possible

through the collective advancement of engineering, design, build and supply in an environment which is arguably the harshest to operate on earth. Full coverage of this year's collection of Great Ships starts on page 38.

I started this column saying thank you, and would like to end on the same note. While the world has changed many times over since our inaugural publication in 1939, our core mission to supply business information to maritime professionals has not. We, like you, are global and mobile. Whether you choose to receive your hard copy and its signature "big red logo" in the mail, our E-magazine edition via your email or tablet, or our 24/7/365 news, analysis and features via MarineLink.com, your support and feedback is appreciated and essential to our next 75 years of success.

trauthwein@marinelink.com

ISSN-0025-3448 USPS-016-750 No. 12 Vol. 76	118 East 25th Street, New York, NY 10010 tel: (212) 477-6700; fax: (212) 254-6271	Founder: John J. O'Malley 1905 - 1980 Charles P. O'Malley 1928 - 2000
--	--	--

Maritime Reporter/Engineering News (ISSN # 0025-3448) is published monthly by Maritime Activity Reports, Inc. 118 East 25th Street, New York, NY 10010. Mailed at Periodicals Postage Rates at New York, NY 10199 and additional mailing offices. Postmaster send notification (Form 3579) regarding undeliverable magazines to Maritime Reporter & Engineering News, 850 Montauk Hwy., #867, Bayport, NY 11705. Publishers are not responsible for the safekeeping or return of editorial material. © 2014 Maritime Activity Reports, Inc. All rights reserved. No part of this publication may be reproduced or transmitted in any form or by any means mechanical, photocopying, recording or otherwise without the prior written permission of the publishers.

			Download our App iPhone & Android	Check out our Websites: www.marinelink.com / www.maritimeprofessional.com / www.maritimepropulsion.com www.maritimejobs.com / www.marinetechologynews.com / www.maritimeequipment.com www.marineelectronics.com / www.yachtingjournal.com / www.maritimetoday.com
--	--	--	--------------------------------------	---

<p>SUBSCRIPTION INFORMATION</p> Subscription Information • in U.S.: One full year (12 issues) \$84.00; two years (24 issues) \$125.00 • Rest of the World: One full year (12 issues) \$110.00; two years \$190.00 including postage and handling. Email: mrcirc@marinelink.com • www.marinelink.com t: (212) 477-6700 • f: (212) 254-6271	<p>POSTMASTER: Send address changes to: Maritime Reporter & Engineering News, 850 Montauk Hwy., #867, Bayport, NY 11705. Maritime Reporter is published monthly by Maritime Activity Reports Inc. Periodicals Postage paid at New York, NY and additional mailing offices.</p>
---	---



Breakthrough protection for long engine life.

Next-generation Mobilgard™ 410 NC offers outstanding wear protection in medium-speed GE and EMD engines, including existing engines, as well as Tier IV designs. Compared* to typical Tier III engine oil performance, new Mobilgard 410 NC is engineered to provide up to 50% less liner wear, up to a 20% improvement in piston cleanliness and significantly improved bearing wear protection. This low-ash, phosphorous-free engine oil is also designed to provide exceptional performance with biodiesel and alternative clean fuels to protect your engines, your boats and your business. It's one more way ExxonMobil moves the marine industry forward. Learn more at exxonmobil.com/marine

Energy lives here™

Mobil Gard™

Performance by **ExxonMobil**

Go Digital @ MaritimeProfessional.com

27,496 Members

When you leave the page and head to the screen, Maritime Reporter's family of online offerings provides the most digital and online news portals for news & insight. For news and insight, visit MaritimeProfessional.com

Over the Horizon

Sad news for Horizon Lines, a company with deep roots in container shipping and the U.S. flag liner trades. New, environmentally compliant vessels will soon enter the U.S.-Puerto Rican trades to take their place.



Joseph Keefe is the lead commentator of *MaritimeProfessional.com*, and is Editor of both *Maritime Professional* and *MarineNews* print magazines. He can be reached at Keefe@marinelink.com

From Charlotte, NC – also my home – comes the November 11th news that Horizon Lines will cease providing liner service between the U.S. and Puerto Rico by the end of 2014 due to continuing losses without prospects of future profitability. It was, for many industry observers, not necessarily an unexpected event, but it did signal the end of a once-proud era of shipping in the Jones Act trades. And, perhaps, the beginning of something equally as impressive.

Separately, Horizon Lines also announced that it had entered into agreements for a series of transactions that would result in the sale of the company. This involved the sale of its Hawaii business to The Pasha Group, followed by Horizon Lines' subsequent acquisition by Matson, Inc.

In 1956, Sea-Land Service, the predecessor to Horizon Lines, pioneered containerized shipping by sailing a converted World War II era T-2 oil tanker, the "Ideal-X", from Port Newark, New Jersey to Port of Houston, Texas. Sea-Land also introduced container shipping to the Puerto Rico market in 1958, which Horizon Lines has continued to this very day. In terms of container shipping, the rest is, as they say, history. The 1956 event changed the way freight is shipped today, created a much more efficient

intermodal supply chain, and provided sustained employment for hundreds of thousands over the intervening years.

Steve Rubin, President and Chief Executive Officer of Horizon Lines said in a prepared statement, "We have a 56-year history in the Puerto Rico trade and truly value the relationships we have established. Unfortunately, a combination of factors, including uncertain prospects for the Puerto Rican economy, losses over recent years and more expected going forward, aging ships that we cannot afford to continue to maintain or replace, and upcoming large capacity additions by two other carriers has led to this difficult but prudent and necessary decision."

In the Puerto Rican trades, Horizon had experienced financial losses and negative cash flow in recent years, despite best efforts to stay competitive. Beyond, this their aging oceangoing fleet was becoming increasingly expensive to maintain.

Looking ahead, at least two other U.S.-flag operators are scheduled to introduce as many as four new, environmentally compliant vessels into service. Those additions will greatly expand capacity in these routes, placing further pressure on Horizon's bottom line. Horizon stressed that its decision to terminate its Puerto Rico service was independent of the oth-

er two transactions and that they would cease operations between the U.S. mainland and Puerto Rico "whether or not the transactions with Pasha and Matson are consummated."

There's no telling how long Horizon could have kept at it had they not faced the eminent pressure of competing in the near future against perhaps as many as four, gleaming, brand new, environmentally correct vessels, with only their existing fleet. In my mind, the announcements that two other U.S. flag operators would ramp up in those trades with new-build tonnage was, if not the last straw, certainly, the beginning of the end. The wisdom – or let's just say viability – of upgrading the existing Horizon fleet to compete with those additions to the area trades, was always questionable.

For myself, I hope that the seafarers sailing aboard Horizon's 13 Jones Act vessels can secure sustainable seagoing employment with other carriers. To say that there was – and is – a lot of experience and competence to be gained from those professionals would be a gross understatement. Shipping out on an older vessel requires a great deal of effort to operate and maintain aging equipment. No doubt these people were very good at it.

The 'take-aways' here are many, but

for the U.S. flag Jones Act compliant fleet in general, the introduction of fully modern tonnage that meets or beats existing and future environmental standards is just one more sign that the industry has cleaned up its environmental footprint measurably in the last 40 years. And that includes the environmental impact of oil pollution, gray water, stack emissions and yes, ballast water treatment, as well. Those who do not continue those efforts on an ongoing basis – in all sectors of our merchant fleets – may also find themselves out of business.

A little piece of the U.S. flag fleet went away this month. The history of what this firm did, and had a hand in, along the way, will not. In Charlotte, North Carolina, the latest Horizon moves will probably have a limited impact on the local economy, but the iconic liner firm was a familiar, longtime resident of the Queen City. I reported on their business activities many times over the course of the last decade. It was never boring and sometimes surprising. Other maritime business stories will, of course, take their place and always provide enough to fill our pages, on line and in print.

That said; I, for one, will miss this group.

– *MarPro*

POWER AT WORK

Engines for propulsion
Engines for auxilliary applications
Tailored transmissions
Type-approved instrumentation

Complete and Committed.

THE SCANIA MARINE SOLUTION.

Out there, confidence in performance, reliability and operating economy are the only things that count. With this in mind, we created the Scania marine solution: An array of flexible products paired with guidance and installation support from Scania. Whatever your specification, we will provide you with the optimal Scania marine solution.

Power at work, every inch of the way.

www.scaniausa.com



SCANIA
Scania U.S.A. Inc.

SHIPBUILDING



Photo by Ricky Thompson/HII

U.S. Navy Aircraft Carrier Leaves Drydock

With tugboats guiding it into the James River, the aircraft carrier USS Abraham Lincoln (CVN 72) was moved from one of Newport News Shipbuilding's drydocks to an outfitting berth. With this move, Newport News, a division of Huntington Ingalls Industries (HII), officially completed the drydock portion of the carrier's mid-life refueling and complex overhaul (RCOH). Now at Outfitting Berth 1, the carrier will undergo final outfitting and testing.

During the drydock phase of the RCOH, Lincoln underwent extensive repair and construction work both inside and out to revamp the ship. Inside, Newport News shipbuilders re-preserved hundreds of tanks and replaced thousands of valves, pumps and piping components. On the outside, they painted the ship's hull, updated the propeller shafts and installed refurbished propellers.

For these last 24 months before the carrier's redelivery, shipbuilders will finish up the overhaul and installation of the ship's major components and test its systems. Shipbuilders must make sure that the electronics, combat and propulsion systems are all operational before the carrier is re-delivered to the Navy in 2016. These final months will also be dedicated to modernizing the ship's living quarters and making them habitable for the sailors as they move aboard. The first group of sailors began moving into the living spaces on Oct. 23.

Lincoln arrived at Newport News in March 2013 for its RCOH and is on track to redeliver in 2016. RCOH is the mid-life refueling overhaul and maintenance availability of a Nimitz-class aircraft carrier that produces a recapitalized carrier capable of supporting current and future warfare doctrine.

Study Using Satellite Data Worldwide Ship Traffic Up 300%

Global shipping routes crisscross the world's oceans.

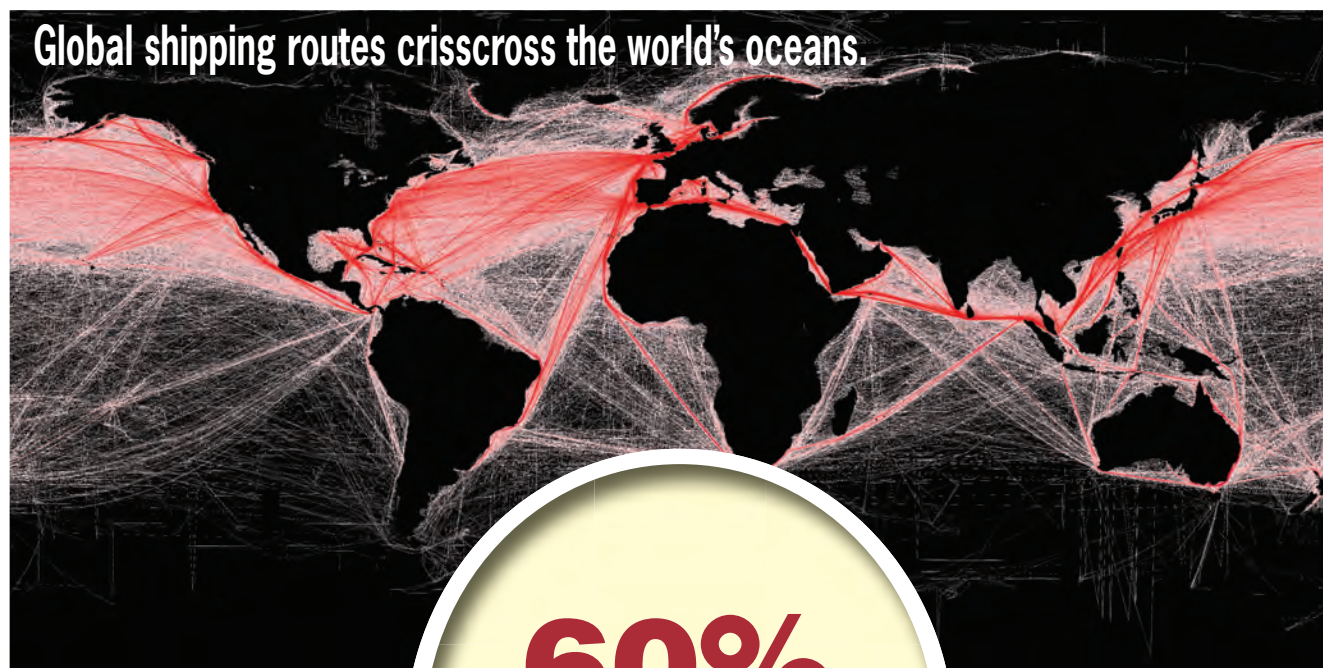

60%

The number of ships traversing the oceans grew an estimated 60% from 1992 and 2002, according to a study of satellite information conducted by Ifremer's Jean Tournadre.

Maritime traffic on the world's oceans has increased four-fold over the past 20 years, according to a new study quantifying global ship traffic. The research used satellite data to estimate the number of vessels on the ocean every year between 1992 and 2012. The number of ships traversing the oceans grew by 60% between 1992 and 2002. Shipping traffic grew even faster during the second decade of the study, peaking at a rate of increase of 10 percent per year in 2011. Traffic increased in every ocean during the 20 years of the study, except off the coast of Somalia, where increasing piracy has almost completely halted commercial shipping since 2006. In the Indian Ocean, where the world's busiest shipping lanes are located, ship traffic grew by more than 300 percent over the 20-year period, according to the research. International trade and the sizes of merchant fleets have both enlarged rapidly over the past two decades, explaining the steep rise in ship traffic, the study reports. The new analysis has been accepted for publication in *Geophysical Research Letters*, a journal of the American Geophysical Union. Jean Tournadre is a geophysicist at Ifremer, the French Institute for the Exploitation of the Sea in Plouzane, and the study author.

The new dataset will provide scientists with invaluable insights into the patterns of ship traffic and the traffic's effect on the environment, said Batuhan Osmanoglu, a radar systems engineer at NASA's Goddard Space Flight Center in Green Belt, Md., who was not involved in the study. "The nice thing about this study is that they have a unique dataset, that maybe we're looking at for the first time," he said. "Whenever you have a unique dataset you can quite easily learn something new."

The new method outlined in the study uses altimeters, instruments that measure altitude, aboard satellites to detect the location of ships at sea, similar to the way these instruments have been used to track icebergs. The altimeter sends a radar pulse down to Earth from the satellite and constructs an image of the surface based on the time it takes the pulse to bounce back to the instrument and the shape of the pulse when it arrives. The method works similar to throwing a ping pong ball at the ground: if you know the velocity of the ball and the time it takes to bounce back to your hand, then you can calculate how far from the ground you are. The shape of the returning pulse can tell you something about the features on the ground. A smooth target like the ocean will bounce back an expected pulse shape, but if something like an iceberg, island or ship is present, the shape of the echo will change.

In 2007, Tournadre was poring over hordes of satellite data for signs of icebergs in polar seas, when he noticed an odd shape in the data. "We had some unconventional data in a region, and careful analysis showed us that it was a lighthouse near shipping lanes," he said. "As we processed the data over the whole globe, we also detected ships."

Tournadre found that the altimetry data accurately reproduced known shipping lanes and could be used to estimate the number of vessels on the ocean worldwide. The study used altimetry data from seven different satellites to map ship traffic from 1992 to 2012. However, Tournadre also cautions that some of the growth he has seen in ship traffic could be overestimated because ships, especially container ships, have become larger over the past two decades and possibly easier to detect with altimetry data.

Credit: Grolitech

The Partnership Yard DSME.

When it rains, your friend DSME will be there for you.



www.dsme.co.kr
DSME, With trust and passion

DSME



Lone

Harald Lone Prediction on Bulk Carrier Market Freight Rates to Peak in 2016

"A fundamental and sustainable dry bulk market recovery is expected in the second half of 2015 and throughout 2016, when the total dry bulk market balance could peak at 88%, with peaks during the fourth quarter close to 92%. Improved tonnage balance in 2015/2016 should drive up bulk rates."

**Harald Lone, Group Chairman,
Newport Shipping Group**

The supply/demand imbalance that drove dry bulk markets down to 2009 levels during the first half of the year is set for adjustment, with Newport Shipping Group predicting an improved tonnage balance over the next couple of years, resulting in a freight rate peak in the 2016/2017 period.

"The dry bulk markets during the first half of 2014, especially Panamax, Supramax and Handysize, have not been at these low levels since the financial crisis in early 2009," said Harald Lone, Chairman of Newport Shipping Group. "Strong supply growth combined with a decline in most of the major coal trades pushed spot earnings for Panamaxes to just above \$3,000 per day in Q1 2014, well below operating costs. The markets are still soft, with average spot earnings in 2014 down by 10% on 2013, with Panamax rates down as much as 22%."

"A fundamental and sustainable dry bulk market recovery is expected in the second half of 2015 and throughout 2016, when the total dry bulk market balance could peak at 88%, with peaks during the fourth quarter close to 92%," Lone said. "Improved tonnage balance in 2015/2016 should drive up bulk freight rates."

Referring to Newport Shipping Group's latest Dry Bulk Market Outlook report, Lone said that less ordering combined with an increase in scrapping is expected to result in a significant shift in the pace of fleet expansion as scrapping eats into new deliveries.

Dry Bulk Expansion

He noted dry bulk supply expansion has gone from 15% in 2011 and 14% in 2012 to 7.4% in 2013 and 5.3% in 2014. It is expected to be about 4.9% in 2015,

although this in itself will not be sufficient to initiate a major dry bulk recovery during the next 12 months.

Dry Bulk Scrapping

Scrapping could eat further into the supply/demand balance, given that 28% of all vessels in the Handy segment, the main contender for demolition, will be 20 years old or more by 2017. Deliveries of new Handy vessels between 2015 and 2016 period will add 13 Mdwts per quarter to the fleet, of which 80-90% will be in the larger 30-40,000 dwt segment.

Dry Bulk Drivers

Key drivers remain the steel industry and Chinese imports of iron ore and steam coal. Iron ore imports to China are expected to increase from the

824 mt registered in 2013

to 1,080 mt in 2016,

which correlates to an annual growth rate of about 9.5%. This,

supported by increases in iron ore to the EU, Japan and other parts of Asia, is forecast

to result in an 8% increase in

the seaborne trade of iron ore during the

2013-2016 period, of which

89% will be imports to China, mainly from Australia and Brazil.

Besides iron ore, steam coal imports to China will be drive future dry bulk demand. However, this year global trade was down by almost 40 mt and Chinese imports were more than 100 mt shy of projections due to falling coal prices, low demand and increased hydro power production – fundamentals that are attributed to the first half weakness of the Panamax, Supramax and Handysize segments.

GOT YOUR ASSET COVERED?



BAKER MARINE SOLUTIONS

- DP ASSURANCE - FMEA STUDIES, PROVING AND ANNUAL TRIALS ATTENDANCE, DP OPERATIONS MANUALS
- VESSEL INSPECTIONS - OCIMF-OVID, IMCA, AND AWO - RCP
- MARINE REPRESENTATION - OFFSHORE AND ONSHORE
- MARINE WARRANTY SURVEYS - LOAD/OFF LOAD SUPERVISION, AS WELL AS MARINE OPERATIONS OVERSIGHT
- SIMOPS - PLAN DEVELOPMENT AND EXECUTION

Now with 24 HOUR SUPPORT IN PORT FOURCHON

BAKER MARINE SOLUTIONS

MARINE CONSULTING, SURVEY, AND
ASSURANCE SOLUTIONS
638 VILLAGE LANE N., STE E.
MANDVILLE, LA. 70471
985-845-9439

WWW.BAKERMARINESOLUTIONS.COM

PROVIDING SOLUTIONS FOR THE MARINE & ENERGY INDUSTRIES

28%

Scrapping could eat further into the supply/demand balance, given that 28% of all vessels in the Handy segment, the main contender for demolition, will be 20 years old or more by 2017.

According to the Paris MOU

MLC2006 Impact: 113 Ships Detained

August 20, 2014 marked the first anniversary of the entry into force of the Maritime Labor Convention (MLC, 2006). During these first 12 months 113 ships were detained by one of the Paris MoU Authorities for MLC-related deficiencies. This represents 17.4% of the total number of detentions (649) in the Paris MoU during this period. During the first year 7.4% (3,447) of the total number of 46,798 deficiencies recorded was linked to the MLC, while 160 (4.6%) were marked as a ground for detention resulting in 113 detained ships. Detainable deficiencies were most frequently recorded in the areas “payment of wages” (39.5%), and “manning levels for the ship” (28.6%). Other areas with high deficiency levels are “health and safety

and accident prevention” (43.1%), “food and catering” (15.4%) and “accommodation” (10%).

Only the member States of the Paris MoU which have ratified the MLC on or before August 20, 2012 were entitled to conduct PSC inspections on MLC requirements from August 20, 2013. As a result the following 12 member States started enforcing the MLC, 2006 from August 20, 2013: Bulgaria, Canada, Croatia, Cyprus, Denmark, Latvia, the Netherlands, Norway, Poland, the Russian Federation, Spain and Sweden.

During the first year of implementation, the following member States began to enforce MLC, 2006: Belgium, Finland, France, Germany, Greece, Italy, Lithuania, Malta and the United Kingdom, bringing the total to 21.

17.4%

MLC-related deficiencies accounted for 17.4% of the total number of detentions (649) in the Paris MoU in a 12-month period from August 2013 to August 2014. During the first year 7.4% (3,447) of the total number of 46,798 deficiencies recorded was linked to the MLC, while 160 (4.6%) were marked as a ground for detention resulting in 113 detained ships.

FULL SPEED AHEAD



Caterpillar marine diesel engines deliver impressive performance throughout a wide speed range with exceptional power density. That means they're as smooth and efficient when you're pulling into dock at an idle as they are when you're heading up the river or out to sea at full throttle.

When it's time to “shove off” in a Cat® powered vessel, there's simply no holding back.

- Caterpillar offers the industry's largest range of marine engines to provide the power you need.
- High-performance or commercial, propulsion is in the name.
- The ease and speed of maintenance gets you quickly on the way.

- Cat marine generator sets and auxiliary engines keep things smoothly running onboard.
- Louisiana Cat is behind you all the way with fully equipped facilities, factory trained technicians, factory authorized warranty repairs and preventive maintenance programs.
- Long-term durability, high fuel efficiency and long life-to-overhaul provides maximum productivity with minimum outlay.

24-HOUR EMERGENCY PARTS AND SERVICE

Call our toll free number below to learn more about our Caterpillar products and services.



ALEXANDRIA

BELLE CHASSE

BOSSIER CITY

LAFAYETTE

LAKE CHARLES

MONROE

MORGAN CITY

RESERVE

NEW IBERIA

PORT FOURCHON

PRAIRIEVILLE

© 2013 Caterpillar. All rights reserved. CAT, CATERPILLAR, their respective logos, “Caterpillar Yellow,” the “Power Edge” trade dress as well as corporate and product identity used herein, are trademarks of Caterpillar and may not be used without permission. www.cat.com www.caterpillar.com

866-843-7440



Louisiana CAT

www.LouisianaCat.com

They said it ...



“Larger ships: The carriers have forced ports around the world to react to their business model of building larger and larger vessels.

Five years ago, 8,000 TEU vessels calling on ports in the U.S. was an uncommon event. Today vessels of up to 14,000 TEU of capacity are calling on the U.S. West Coast. The JOC has reported that these large vessels regularly generate 5,000 container moves per vessel call, and sometimes as many as 8,000 to 10,000 container moves. This large volume places a severe strain on terminal resources ... In the U.S., ports are spending tens of billions of dollars upgrading their ports in anticipation of larger vessels. The larger ships have come onto the market quicker than the ports can react by way of construction and upgrading, thereby, significantly exacerbating port congestion by unloading ever larger volumes of containers.”

U.S. Federal Maritime Commission (FMC) Commissioner
William P. Doyle statement regarding port congestion.

“We’ve learned that LNG really isn’t Rocket Science.

Yes it is a cryogenic system; yes it is a high pressure system, but we know how to build those. It isn’t something that takes us out of our core strength as a shipbuilder.”

Kevin Graney, VP and GM, NASCCO, discussing the progress on the world’s first LNG-fuelled containerships being built for TOTE in San Diego. **See story on page 24**



Photo: Greg Trauthwein



“The most significant impact of a lower oil price is an increase in oil demand.

Lower prices may trigger stockpiling or have a more general positive impact. A saving of \$20 per barrel equates to savings for the U.S. of about \$55 billion annually. Such an oil price decrease has the same effect on the overall economy as a tax reduction.”

Herbjørn Hansson, Chairman & CEO
 Nordic American Tankers Ltd.,
 in a letter to shareholders

Cummins, Konrad Unveil Diesel Sterndrive Package

Less than one year after announcing the formalization of their relationship, Cummins and Konrad Marine confirm they have added 480 and 550 hp ratings to the diesel sterndrive packages they jointly offer. The 480 rating is approved for both leisure and commercial applications. The companies report that the new package performs favorably in terms of additional horsepower and torque.

The 550 rating is currently intended for leisure applications, with 875 ft. lbs. of torque.

“These power ratings, coupled with the inherent advantages of diesel, start a very compelling conversation,” said Julie Heifner, Global Business Development Manager for Konrad Marine. Add to this, the exceptionally long life of this package; the fact that Konrad sterndrives can be rebuilt up to 7 times to full integrity vs. being replaced; and now you have a solution with an extremely low cost of ownership.” A variety of packages are available using one of six sterndrive models and nine variations of the QSB 6.7L engine so installations can be optimized to meet the customer’s top priorities. For example, if efficiently managing heavy loads is the goal, four dual prop models are available with car-

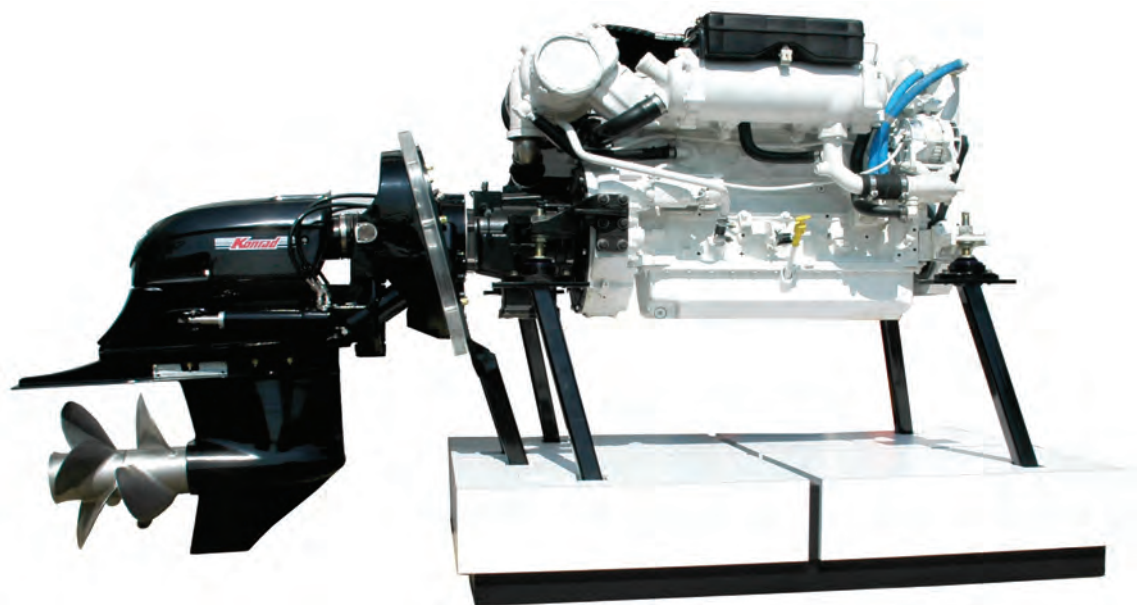

rying capacities up to 18,500 lbs. (8.4 metric tons) per drive. Offering the components from gauges to props in predefined, fully integrated packages simplifies configuring, ordering, installation, service and support, and ensures consistent and successful

applications - and a single point of contact for the builder. “These packages offer significant advantages for our customers in power, longevity, and cost of ownership,” says Geoff Conrad, Director of Marine Business for Cummins NW, USA.

TURN-KEY SERVICE SUPPORT

Engine - Turbocharger - Filtration - Auxiliary

For over 30 years, **MSSH** has set the standard for quality engine service, experienced technicians and cost-saving turnarounds. Utilizing our extensive spare parts inventory, **MSSH** can mobilize a team, inventory, and equipment 365 days a year, or we can support your equipment from one of our modern repair facilities in Florida, Louisiana or the Bahamas.

For more information, call + 1 954-763-3660 or toll free 800-622-6747 or visit www.mshs.com.

Authorized Service Partner of
MAN | PrimeServ



MSSH

Motor-Services Hugo Stamp, Inc.
Authorized Distributor and Service Center

FLORIDA/BAHAMAS +1 954-763-3660

LOUISIANA +1 504-265-8800

Toll Free 800-622-6747 | info@mshs.com | www.mshs.com

Since
1917



The Innovators in Fire Suppression since World War I.

Our time-tested fire suppression systems protect a wide range of vessels and spaces including: Engine Rooms • Cargo Spaces • Galleys • Control Rooms • Lube Oil Rooms • Paint Lockers • Thruster Rooms • Switchgear Spaces • Machinery Rooms

Visit our website at www.kiddmarine.com to find an authorized distributor in your area.



KIDDE MARINE FIRE SUPPRESSION SYSTEMS

**FIRE PROTECTION
FOR PEOPLE
AND PROPERTY**

Quarantine & Isolation



BY DENNIS BRYANT

Seven years ago, I authored an article on quarantine and isolation. With the outbreak of Ebola virus disease (EVD) in West Africa, it is time to dust off and update that article.

The concepts of quarantine and isolation lie at the juncture of medicine, law and public safety. When these concepts intersect with the maritime community, things quickly get both interesting and complicated.

Quarantine and isolation have been invoked in cases of communicable diseases throughout human history. Special treatment of lepers is mentioned in the Bible. During the Middle Ages, the Venetians required ships arriving from suspect areas to anchor out of port for 40 days, based on the assumption that any disease on board would run its course during that time. Modern quarantine and isolation are more sophisticated, but only slightly. The outbreak of severe acute respiratory syndrome (SARS) in 2002 revealed the difficulty of instituting efficient and effective quarantine and isolation protocols in an interconnected world village. EVD, and its isolated occurrence in the United States and Western Europe, have provoked fresh reactions. Other illnesses, such as avian flu and Middle East respiratory syndrome (MERS), present their own challenges.

Congressional hearings have been held. Some members of Congress have called for travel bans. Health agencies and law enforcement agencies are re-examining their procedures and their authorities and have commenced enhanced monitoring of arrivals. The U.S. Coast Guard and sister agencies in other port states have issued requirements for and reminders relating to disease reporting. New regulations and enhanced utilization of existing protocols should be expected. Concern about a possible pandemic caused by an emerging disease is growing.

Definitions

Now is a good time to define some



terms. “Epidemic” is the widespread occurrence of a disease. A “pandemic” occurs with the outbreak of a new contagious disease that causes death or serious illness in large numbers of persons. EVD is not considered to be likely to develop into a pandemic. While highly virulent with a death rate of about 50% among those infected, it has a low capacity for contagion. SARS is a recent example (but fortunately was stopped before becoming widespread, making it an epidemic rather than a true pandemic), but the Black Death in the Middle Ages, the so-called Spanish flu in 1918-1919 and flu outbreaks in 1957 and 1968 are other examples. “Isolation” involves the separation of a person who has been diagnosed with a specific infectious disease from those who are healthy and a restriction of the movement of that individual to stop or deter the spread of the illness. In most cases, isolation is voluntary, but authority exists for compulsory isolation if proven necessary. Persons in the United States diagnosed with EVD have been placed in isolation. “Quarantine” is the separation and restriction of movement of persons who, while not yet ill, may have been exposed to an infectious agent. As with isolation, quarantine is generally voluntary, but may be enforced when and if necessary.

International Impact

SARS, which was first identified in southeast China and Hong Kong in late 2002, provides a good example of a potential pandemic and the impacts that flow therefrom. While governments did not impose mass quarantines and isolations, travel was effectively restricted and commerce was impaired. The SARS epidemic caused over 8,000 reported cases of the condition, including almost 800 fatalities. In China, Hong Kong, and Southeast Asia during the height of the epidemic (second quarter of 2003), the gross domestic product of the affected nations is estimated to have dropped 2% on average. If a pandemic were to occur in the near future with the same severity as SARS, but not so limited in geographic impact, the World Bank estimates an economic impact of approximately \$800 billion.

EVD has had less, but noticeable, impact on travel and trade. Various airlines have ceased regular flights to the affected West African countries. Maritime trade has been restrained for ports in the region. Owners, operators and traders have started inserting into charters and other contracts clauses to address the threat of EVD, seeking to minimize the risk of delay if a vessel after calling at

a port in West Africa transits to other ports. If delay occurs, some clauses allocate in advance the financial liability that ensues.

Justifiably, concern about a potential pandemic is widespread. The World Health Organization (WHO), a sister agency to the IMO within the United Nations, implemented new and enhanced International Health Regulations on June 15, 2007. The regulations are intended to provide for improved procedures for addressing significant health emergencies and address a wider range of medical conditions than previously. Among other things, the revised IHR provide for a declaration of health by ships and for minimum sanitary conditions for cargo loading areas, including areas where shipping containers are packed. Following the EVD outbreak, the WHO issued biorisk reduction guidance, but has specifically stated that bans on travel and trade are inappropriate. The IMO has endorsed the WHO position.

United States Approach

In the United States, isolation and quarantine are generally matters for state and local health authorities and law enforcement agencies. Only when the problems involve interstate and international movement and exceed the ability of local control do the federal authorities normally step in.

At the federal level, quarantine and isolation are primarily the responsibility of the Centers for Disease Control and Prevention (CDC). The CDC is empowered to detain, medically examine or conditionally release individuals reasonably believed to be carrying a communicable disease. The list of quarantinable diseases is established by a 2003 Executive Order, which was amended in 2005 to include “influenza caused by novel or reemergent influenza viruses that are causing, or have the potential to cause, a pandemic” and in 2014 to redefine severe acute respiratory syndromes. As of the date of writing this article, EVD

has not been added to the specific list. Isolation or quarantine, though, may be ordered by state or local authorities if appropriate.

Changes in Regulations

In recent years, the quarantine and isolation regulations have been amended several times. The changes, among other things, make it easier for the CDC to require a ship clearing or departing a foreign port bound for the United States to obtain a bill of health from the US consular officer for that port setting forth the sanitary history of the vessel. The CDC can also suspend, in whole or in part, entries and imports from designated foreign countries or places. This would be done when the CDC Director determines that the risk of introduction of a disease into the United States is increased by the introduction of persons or property from such foreign countries or places.

Operators of ships on international voyages are required to report deaths or illnesses prior to arrival. Operators are required to report not just persons on board with a designated communicable disease, but persons defined as ill, meaning a person who: (1) has a temperature of 100.4°F (38°C) or greater accompanied by one or more of the following: rash, swelling of lymph nodes or glands, headache with neck stiffness or changes in level of consciousness or cognitive function; (2) has a temperature of 100.4°F (38°C) or greater that has persisted for at least 48 hours; (3) has more than common diarrhea; (4) has severe bleeding, jaundice or severe persistent cough accompanied by bloody sputum, respiratory distress or a temperature of 100.4°F (38°C) or greater; or (5) displays other symptoms or factors that are suggestive of communicable disease.

Arriving vessels are subject to inspections and sanitary measures may be directed if there is evidence that the ship or something on board is or may be contaminated with a communicable disease. The ship may be detained until satisfactory sanitary measures have been completed. The owner of the ship would bear any expenses relating to sanitary measures and detention. In the case of animals, articles or things on board the ship, any expenses relating to detention would be borne by the owner thereof.

The CDC may, at U.S. ports, conduct screenings of arrivals to detect the presence of ill persons. Any person reasonably believed to be infected with or exposed to a quarantinable disease may be provisionally quarantined. If evidence (such as diagnostic tests) indicates that an arrival is infected with or has been

exposed to a quarantinable disease, the CDC may issue a quarantine order to that person. A person for whom a quarantine order has been served may not be required to undergo medical treatment, but may be subject to movement restrictions throughout the period of incubation and communicability of the disease.

Persons violating the quarantine laws and regulations would be subject to a fine of up to \$250,000 or one year in jail or both. Violations by organizations could result in a criminal fine of up to \$500,000.

Port State Measures

Various port state administrations, including the U.S. Coast Guard, have adopted measures intended to reduce the risk of introduction of EVD via maritime vectors. The Coast Guard issued a notice reminding owners, operators and masters of the obligation to report hazardous conditions on the vessel prior to arrival. The Coast Guard considers an ill person on board an arriving vessel displaying symptoms of EVD to constitute a reportable hazardous condition. The agency also monitors advance notices of arrival to determine if a vessel has visited a CDC-designated EVD country within the previous five port calls. Other port administrations, including France, the Netherlands, Singapore, Spain and the United Kingdom, have adopted similar measures.

Summary

The real penalty regarding communicable diseases such as EVD is not government-imposed financial sanctions but the potential disruption in maritime trade. Due to the potential reduction in international trade resulting from communicable diseases, many ships would be without cargoes (and possibly crews, support personnel and bunkers). Ships could end up delayed in departure ports because the arrival ports are not accepting ships therefrom. Alternatively, the ship could be required to anchor out for an extended period awaiting clearance – recalling the ancient *quaranta giorni* or 40 day delay imposed by Venice. All of this would add fresh meaning to the concept of “restraint of princes.”

The Author

Dennis L. Bryant is with Maritime Regulatory Consulting, and a regular contributor to Maritime Reporter & Engineering News as well as online at MaritimeProfessional.com.

t: 1 352 692 5493

e: dennis.l.bryant@gmail.com

CLICK BOND®

ADHESIVE - BONDED FASTENER TECHNOLOGY

- Reduces Cost by Eliminating Hot Work and Gas Freeing
- Maximizes Design and Work Sequence Flexibility
- Facilitates and Simplifies Repairs at Sea
- Protects Against Galvanic Corrosion



PIONEERING > ADVANCED > SOLUTIONS

2151 Lockheed Way Carson City NV 89706 +1-775-885-8000 CLICKBOND.COM



Floating Production

Monitoring to support inspection, maintenance and repair of offshore structures



BY REMCO HAGEMAN

Maintenance is essential for operators of high performance craft and offshore units and relevant and up-to-date information is required to make well-informed decisions. As an FPSO does not enter drydock for regular inspections in-field maintenance is very important. On the other hand, inspection and maintenance is expensive because it requires a partial interruption of production, tank cleaning and the availability of specialized personnel. Moreover, inspection and maintenance activities introduce risks for both the people performing the maintenance and the structure. Therefore, careful planning is vital.

Classification societies and operators make increasing use of risk-based approaches to determine rational inspection intervals for offshore structures. Detailed information is required to make a thorough assessment and classification societies naturally make use of their extensive experience. However, important information for a specific unit can be retrieved through monitoring. This can significantly improve the inspection scheduling for that unit. The application of condition-based inspection and maintenance ensures that maintenance is conducted when needed, while at the same time avoiding the costs of conducting maintenance at an uneconomical fre-

quency. The AHMS system of MARIN is used to capture fatigue loads on an FPSO hull. Measurements from such a system can also be used to support maintenance decisions. Based on this, an exploratory analysis has been executed by Delft University of Technology, Bureau Veritas and MARIN. Measurements from an AHMS system have been used to calculate fatigue failure probability of one critical structural detail. This was compared with the results of design calculations. The uncertainties in the load can be assessed using results from long-term monitoring campaigns. This is important input for the risk-based assessment to determine inspection, repair and main-

tenance activities. By using monitoring data, a great improvement can be made for this unit's specific assessment. Current research efforts within the Monitas Group are striving to complete this goal. Undoubtedly, this application shows that continuous monitoring can provide very practical benefits.

The Author

Remco Hageman is Project Engineer at the Hydro-Structural Services group of MARIN, the Maritime Research Institute Netherlands.

e.r.hageman@marin.nl

Naval Architects & Marine Engineers

New-build designs underway and about to begin



We are hiring immediately for open positions on our design and engineering teams

Competitive Pay Packages including:

- Health Coverage
- Life Insurance
- Vacation Pay
- 401K



CHESAPEAKE SHIPBUILDING
SHIPBUILDERS & NAVAL ARCHITECTS

1-800-784-2979

www.chesapeakeshipbuilding.com



STAY ON COURSE



NOT ON BLOCKS

**Neptune® PAGs last longer and
comply with EPA VGP.**

Neptune series lubricants are the only fluid chemistry fully compliant with the 2013 VGP, U.S. EPA Clean Water Act and U.S. Coast Guard Surface Force Logistics Center EAL Standards. But why stop there? Neptune lubricants outperform fully-saturated synthetic esters, vegetable oils and bio-PAOs. And they last longer in your submerged equipment. That's a whole lot of upside. Let's talk today.

NeptuneEALs.com



AMERICAN CHEMICAL TECHNOLOGIES, INC.

LNG as a Fuel

As Interest in Surges, Regulators Struggle to keep Pace



BY JOAN M. BONDAREFF

The use of Liquefied Natural Gas (LNG) as a transportation fuel for ships, barges and ferries has surged in recent months. This surge is due, in large part, to the boon in the production of natural gas in the U.S.; new low sulfur rules for the North American Emission Control Area (ECA), which go into effect on January 1, 2015; and new technologies for the construction of engines capable of running on LNG. Regulatory regimes both in the U.S. and worldwide are struggling to keep pace with the tremendous growth of LNG as a fuel.

Background & News

In the past two months, under the leadership of its new Administrator, Paul “Chip” Jaenichen, the Maritime Administration (MARAD) has taken two major

steps to encourage the use of LNG as a transportation and bunkering fuel.

The first major step was the approval of a \$324.6 million loan guarantee under the Title XI program to TOTE Shipholdings to finance the construction of two new containerships that will use LNG as propulsion fuel. These ships are being built at the General Dynamics-NASSCO shipyard in San Diego, CA. According to MARAD, the construction of the new ships will generate 600 jobs at NASSCO and suppliers around the U.S. Once built, the ships will be placed in the Jones Act trade and carry freight between Jacksonville, FL, and Puerto Rico.

MARAD touts that the TOTE ships “will be the most environmentally friendly containerships in the world” because the “new engines will reduce particulate emissions to levels well below EPA man-

dates.” (DoT Fast Lane blog, September 23, 2014). Designed by DSEC, a subsidiary of South Korea-based Daewoo Shipbuilding, the ships include DSEC’s patented LNG fuel-gas supply system and a MAN ME-GI dual-fuel slow-speed engine. Notably, NASSCO also has a contract with American Petroleum Tankers to build four new product carriers that will be ready for conversion to use LNG fuel. Crowley is also building two new LNG-powered containerships at VT Halter Marine—also for the Jones Act trade.

Second, MarAd released an LNG Bunkering Study prepared by DNV-GL. (Report No. PP087423-4, September 3, 2014). This comprehensive study addresses the current regulatory environment for the use of LNG and identifies the regulatory gaps that need to be filled

in order to support a bunkering infrastructure in the U.S. The study concludes that “LNG is an attractive fuel choice for many vessels because it exceeds the air quality standards set forth in the ECA, and the price of LNG is significantly lower than ECA-compliant fuel.” The DNV-GL report also noted, however, that significant safety and regulatory gaps exist because the use of LNG as a marine propulsion fuel is a relatively new concept in the U.S. Among the key regulatory gaps DNV-GL identified are the lack of a set of comprehensive federal and state regulations for bunkering and associated infrastructure, and proper training for crew and operators.

Subsidy Programs for LNG

The DNV-GL report also revealed that the U.S. regulatory regime falls short of the regimes already in place in the EU. For example, Norway already has five LNG bunkering installations in operation and has created a private investment fund where ship owners could receive 50% subsidies for using “green technologies.” (DNV-GL study at 24).

The European Commission, with heavy support from the European Maritime Safety Agency, is developing a comprehensive set of rules, standards and guidelines for LNG provision, bunkering, and use in shipping. (European Maritime Safety Agency, available at <http://www.emsa.europa.eu>.)

The International Maritime Organization (IMO) also has made progress amending the draft “International Code of Safety for Ships using Gases or other Low Flashpoint Fuels;” however, its “Interim Guidelines on Safety for Natural Gas-Fuelled Engine Installations in Ships” have remained in “interim” status for more than five years. (Resolution MSC.285(86)).

Plan for Catching Up with Europe

To ensure the full potential of LNG as a marine fuel worldwide, the maritime industry needs both executive and con-



World Leader
in Fuel Monitoring Systems



FloNET DataLog System

Displays, Records & Transmits Fuel Flow and Vessel Data



Commercial fleets worldwide are installing FloScan to obtain a complete record of vessel fuel consumption for billing purposes and to improve fuel economy up to 20%. Here in the U.S., inland tug and barge operations are now using FloScan’s new **GeoFencing** feature to document fuel consumption totals on a district-by-district basis for fuel taxation purposes. Our latest software development, DataLog, combined with our FloNET Fuel Monitoring System provides these features at a fraction of the cost of the competition.

With more than 750,000 installations worldwide over the past 40 years, FloScan Fuel Monitoring Systems set the industry standard while also being the safest and most cost effective solution on the market today.

Flowmeter Features

- **Engineered for diesel engines** – developed specifically for diesel engine flow monitoring
- **No fuel bypass line required** – internal bypass design makes it immune to fuel blockage
- **Low pressure drop** – meets all engine manufacturer fuel restriction specifications
- **Multipoint calibration** – systems are calibrated at 6 flow points for superior accuracy
- **Repeatability** – 0.5% guaranteed
- **Range** - fits most diesel engines up to 6000 HP
- **Cost** – priced up to 50% less than the competition

For more info, contact Joe Dydasco
Tel: 206-524-6625 ext. 316
E-mail: joe.dydasco@floscan.com
Seattle, Washington USA

Stainless Steel
Flowmeters Now Available

www.floscan.com

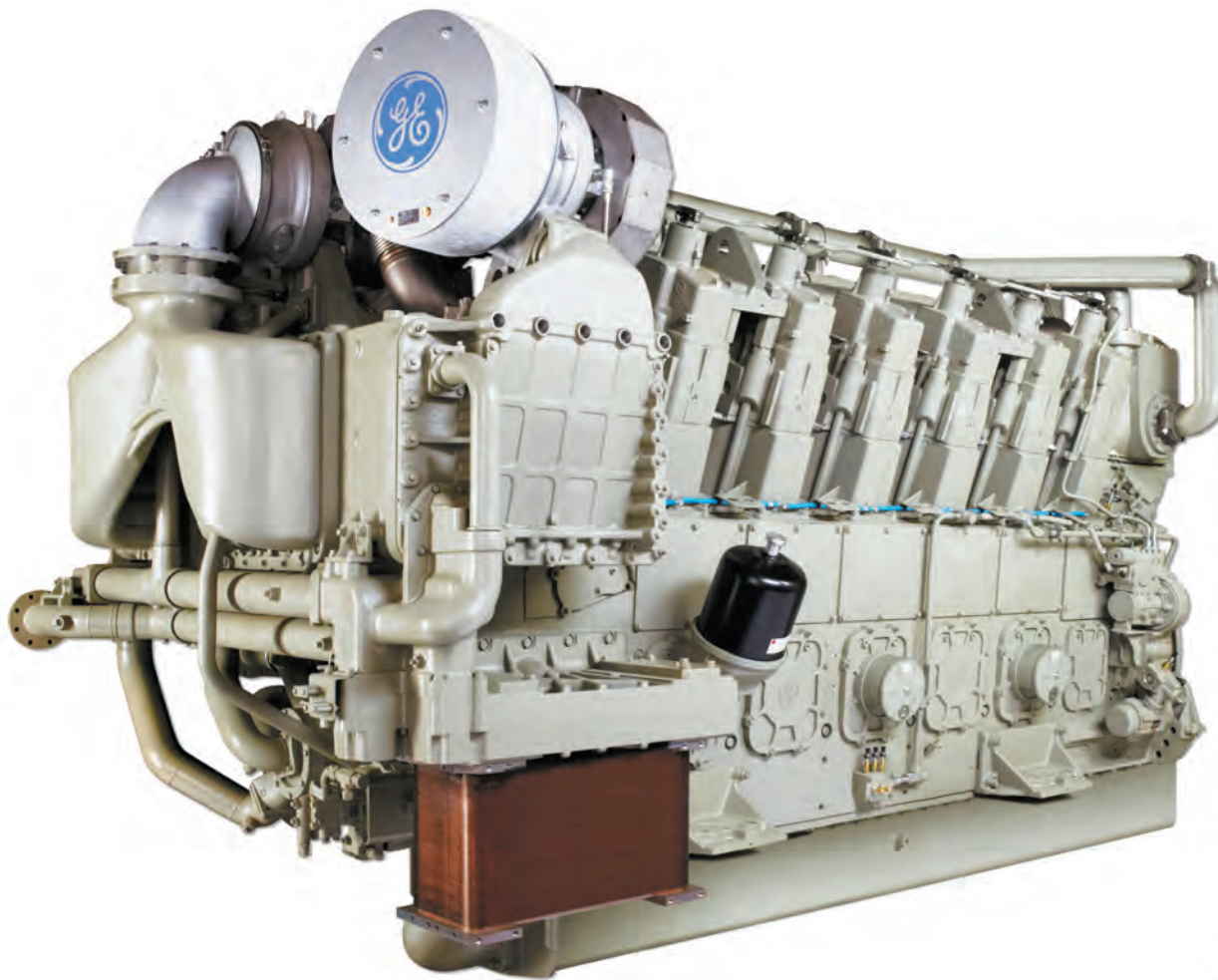

V250 Series
Diesel Engine

With GE Marine, No After-Treatment Required.

Breakthrough non-SCR diesel technology meets EPA Tier 4 and IMO Tier III compliance

As a global leader in emissions-reducing solutions, GE Marine again is at the forefront with its innovative non-SCR diesel technology that requires no urea-based after-treatment. This advanced technology reduces key emissions by more than 70% and enables in-engine compliance with EPA Tier 4 and IMO Tier III emissions standards.

The result of an eight-year investment, this breakthrough non-SCR diesel engine technology:

- Available on GE Marine's L250 and V250 Series Diesel Engines
- Eliminates SCR and urea use and storage to preserve cargo, accommodation and tank space
- Requires no supplemental equipment or fluids, reducing capital and operating expenditures
- Reducing ship design complexity and shipyard installation time and cost

Imagination at work.

www.getransportation.com
ge.marine@ge.com



MARAD touts that the TOTE ships “will be the most environmentally friendly containerships in the world.”

Designed by DSEC, a subsidiary of South Korea-based Daewoo Shipbuilding, the ships include DSEC’s patented LNG fuel-gas supply system and a MAN ME-GI dual-fuel slow-speed engine. Notably, NASSCO also has a contract with American Petroleum Tankers to build four new product carriers that will be ready for conversion to use LNG fuel.

gressional action in the U.S.

The U.S. cannot make strides in LNG regulation without Congress playing a significant role. The House Transportation and Infrastructure Committee and the Senate Commerce, Science and Transportation Committee should take the lead on developing legislation to fill the regulatory and policy gaps discussed above. Such legislation should include a one-stop permitting model for infrastructure development similar to the one used in the Ocean Thermal Energy Conversion Act of 1980 (Pub. L. 96-320). It also should confirm that LNG can be used as a fuel that complies with current and future EPA and ECA standards.

To avoid the political pitfalls of ballast water legislation, which has been mired down in endless Congressional debate over preemption, the legislation should set national guidelines that state and local governments can use as guidance but does not create a patchwork quilt of state and local laws and regulations with vary-

ing standards.

The U.S. needs to designate a lead agency to develop the policy and the regulatory structure for the use of LNG as a transportation fuel. One option is MARAD with the assistance of the Coast Guard, EPA and the Army Corps of Engineers. The DNV-GL study, above, describes the patchwork of agencies in charge of various aspects of this problem—too many to lead to an efficient result.

Once designated, the lead agency should convene a workshop with industry, NGOs and key regulatory agencies to debate the policy and regulatory gaps, and identify the need for financial incentives to promote LNG as a clean transportation fuel.

The lead agency, with other interested agencies, must promptly address at least three key issues: crew and operator safety, financial assistance programs and the Marine Highway Program.

To address issues of crew and opera-

tor safety, the U.S. Department of Labor, working closely with the U.S. Coast Guard and respective maritime unions and schools, should administer programs to increase safety.

Agencies must also consider financial assistance programs to incentivize the construction of new ships, ship engine conversions and new portside bunkering infrastructure. The following federal grant and assistance programs could be utilized: the Environmental Protection Agency’s Diesel Emissions Reduction Act (DERA) Program; the Department of Transportation’s (DOT) Transportation Investment Generating Economic Recovery (TIGER) infrastructure grant program; port security grants at the Federal Emergency Management Agency (FEMA), a part of the Department of Homeland Security (DHS); Small Shipyard Grants at MARAD/DOT; the Capital Construction Fund (CCF), which is implemented by MARAD and the Internal Revenue Service; and MARAD’s

title XI loan guarantee program, which assisted in the financing of the TOTE containerships, above.

The Marine Highway Program (MHP) is also essential for strengthening the U.S. port bunkering infrastructure. This program, initiated by MARAD, has not had much Congressional support, but will be useful for designating ports that can handle infrastructure for bunkering operations. To make MHP a reality, MARAD and other agencies should explore the use of private investment and public-private partnerships for developing and funding infrastructure projects, similar to those authorized by the Water Resources and Reform Development Act of 2014. (Pub. L. 113-121).

Unless there is legislative action to create a legal framework for LNG to thrive, and executive action to designate a lead agency to consolidate layers of regulation, the growth of LNG as a marine fuel may not reach its potential.

Conclusions

The U.S. has taken the first steps to promote LNG as a clean maritime transportation fuel, but Congress and the Administration must now develop a well-coordinated LNG policy and regulatory regime and a package of needed financial incentives and training programs to foster an environment in which LNG can continue to safely take off as a marine fuel.

** Joan Bondareff would like to thank Stefanos Roulakis, an associate in the Firm’s maritime, international trade, and government contracts group, for his assistance in writing this article.*



Positioning - for success.

- 8 cm accuracy worldwide (2 drms)
- High accuracy Heading/Pitch and Roll sensors
- GPS, GLONASS and GNSS solutions
- QA/QC NMEA outputs compliant with OGP 373-19 / IMCA S 015
- Precise Stable & Reliable
- Easy to Install



www.cnav.com

Angola • Brazil • Mexico • Singapore • South Africa • United Kingdom • USA

The Author

Joan M. Bondareff, of counsel at Blank Rome LLP, represents clients in many industries and state and local governments in marine transportation, environmental and legislative issues.

T: 202.772.5911

e: Bondareff@BlankRome.com

WE POWER YOUR BUSINESS



engines, inc.
Your Power Source



INTEGRITY SETS US APART

engines, inc.
Jonesboro, AR • 800-562-8049
Conroe, TX • 936-441-5592

www.enginespower.com

24-Hour Service Line
870-268-3799



YOUR BEST CHOICE

FOR RELIABLE POWER FROM 40kW to 250kW

When reliability is critical you need an engine you can depend on. That's why we use **John Deere PowerTech™** engines which are durable, fuel efficient, and easy to maintain. They are also backed by the support of one of the strongest engine and equipment companies in the world.

On the inland waterways, your generator set powers your bottom line. When you choose a power generation package from **engines, inc.**, you can rest assured that you are getting the best engineered package available anywhere and we stand behind it with the most reliable 24/7 support structure in the business. Our extensive dealer network is able to provide reliable service and dependable support wherever you are, whenever you need them and our skilled staff is always available on our 24-Hour Service Line.

24-HOUR SERVICE LINE

870-268-3799

With over 150 years of collective experience in our shop and over 75 years of partnership with John Deere, we are, without a doubt, your best choice for Generator Sets and Propulsion Engines on the inland waterways. Our experience distinguishes us and our integrity sets us apart. When everything is on the line you can count on us: **We Are Your Power Source.**

NASSCO

General Dynamic's NASSCO in San Diego arguably has the most diverse and enviable shipbuilding backlog in the U.S., with its navy and commercial orderbook stretching out for three years. With the yard humming at record pace, we sat down with Kevin Graney, VP & GM in San Diego to discuss how he and his team intend to keep the momentum rolling forward.

By Greg Trauthwein, Editor

Pictured is **Kevin Graney**. In the background is the first **LNG-fuelled containership for TOTE**, nearly 75% complete in San Diego.



Engineering & Design for Lean Shipbuilding

Unlock the power of your digital asset

AVEVA's Integrated Engineering & Design software solution provides a flexible environment for multi-discipline, global engineering and design teams. It enables highly efficient collaboration that delivers improved quality, more accurate scheduling and increased productivity.

This open and flexible solution offers rapid set up, controlled communication with a unique Compare & Update capability and enhanced integration of 2D engineering schematics with 3D design models. The AVEVA Integrated Engineering and Design solution allows AVEVA customers to master change in an increasingly complex world.



Photos: Greg Trauthwein

Above: The first of two LNG-fuelled containerships for TOTE is being built on the incline shipbuilding ways at NASSCO.

Below: One of two of the massive LNG fuel tanks for the ship.



Photos: Greg Trauthwein

General Dynamics National Steel & Shipbuilding Co. – NASSCO – has quietly become the face of U.S. shipbuilding, deftly balancing a newbuild and repair workload with the U.S. Navy while simultaneously amassing arguably the strongest commercial orderbook, a commercial backlog which includes eight tankers and two container-ships, the latter being the world’s first LNG-fuelled containerships for TOTE.

“To me the key is having that ‘open kimono’ approach with the customer,” said Graney in explaining how NASSCO is able to juggle a navy and commercial workload in the same facility, a feat that many shipbuilders have tried and failed. “Whether they are government or commercial customers, it’s about getting the details nailed down as soon as possible.”

As any shipbuilder can attest, money is made or lost in the planning stage, with changes to the ship growing more costly with each passing day. That’s why Graney is particularly proud of the company’s performance on the U.S. Navy’s Mobile Landing Platform (MLP), two of which are delivered with the third variant floated out early last month.

“There were a lot of commercial best practices that we incorporated into the MLP program and it worked great,” said Graney. “So here we are, we have a lead ship – a navy lead ship – delivered with only 2.5% re-work, which is unheard of in the Navy: fixed price, on schedule, under budget. So we took a commercial model, applied it on the government side and made it work.”

While the MLP – Lewis B. Puller – is the third in the series, in some respects it has lead ship qualities as it is designated MLP 3 / AFSB, the first to be equipped with a flight deck, a hangar and accommodations for about 250 people. This variant is designed to conduct mine countermeasure warfare with the Navy, with space available to support special ops.

The third ship’s flexibility and affordability comes courtesy of its flight deck, a flight deck which is geared towards helicopters, but can also support as many as four MV22’s, according to a recent study of the space. So with its lift capacity, flexibility and price tag, the ship is viewed as a tremendous value for the investment.

“The MLP is really like the Ford F150 pick-up truck; you can put anything you want in the bed; in this case we put a flight deck on it,” said Graney. “It is a versatile platform, and it’s exciting for us because the demand signal looks in our favor. This was a three-ship program a few years ago; we’re in the process of negotiating the fourth ship; and this year the Navy put in a fifth ship. We’re keeping our fingers crossed on that fifth ship.”

The TOTE Ships

The pair of LNG-fuelled containerships being built for TOTE dominate the San Diego shipyard, both being built on the yard’s incline shipbuilding ways. At the time of our visit in mid-November, the ships were 72% and 33% completed, respectively.

“I can’t believe how quickly that ship is coming together,” said Graney. “Last week we lifted 3000 tons in the shipyard, most of that on the TOTE ships; which is the most steel blocks that we have erected in a week.”

Graney said that DSME – the Korean builder with whom NASSCO has had a close relationship with for nearly a decade – “thought we were nuts” for building these ships on the incline ways, because being perfectly square is crucially important when building a containership, and throwing in a 2.5 degree angle is not the optimal build solution. But the shipyard’s graving dock, which was designed for the construction of tankers and is relatively shallow, was not suited for the ships, so the choice was made. Graney

admits there was some concern at the outset: “We were worried about the longitudinal strength members of the containership. We had to make that highly accurate; that’s up to 65mm steel. We built a jig for the transverse bulkheads as well for the cell guides, so the cargo holds have come out very accurate.”

Though the shipyard had not built a containership in nearly 20 year – and it had never built any LNG-fuelled vessel – it had little to no concern that it would be done successfully and efficiently, leaning on its partnership with DSME for timely insight and advice.

“We’ve learned that LNG really isn’t rocket science,” said Graney. “Yes it is a cryogenic system; yes it is a high pressure system, but we know how to build those. It isn’t something that takes us out of our core strengths as a shipbuilder. I think the testing program will challenge us a little bit, there’s a little bit of risk there, but that’s something we’re looking at very hard right now.”

“Part of the beauty of the relationship that we have with Korea is that they have such a handle on state-of-the-art marine equipment,” Graney continued. “We’ve had no issues in terms of manufacturing and first article testing and shipping (to San Diego). The ME GI engines have both passed their first article tests. MAN is committed to making sure these engines are the benchmark for LNG engines, so we’ve gotten a lot of cooperation from them. And even the fuel gas system (FGS) is a DSME creation, designed and patented by them, and has already been in operation over there.”

As the ships have progressed at NASSCO and additional orders for more LNG-fuelled vessels have been placed around the world, questions and concerns surrounding the fuel itself are starting to fade, said Parker E. Larson, Director, Commercial Programs, NASSCO. “We don’t have a conversation (with a shipowner) today where LNG does not come up. People now realize it’s something that you can put on a ship. I don’t see much worry surrounding LNG other than the concerns such as ‘what is the cost to put it on’ and ‘where do we go to get the supply.’”

In fact the most concern for NASSCO concerning the LNG system was not the technical system, rather the increased U.S. Coast Guard involvement and oversight of the project given its unique nature. “We were concerned about the Coast Guard involvement on this,” said Graney. “We always go with ABS in this yard, and we go with the Alternate Compliance Program that ABS offers in acting

for the Coast Guard. When LNG came along, the Coast Guard allowed ABS to handle the things that were typical shipbuilding matters, but when it came to LNG they wanted some oversight. But Graney and his team approached this as

they approach all business relationships: straight-forward with all cards on the table ... or “open kimono” as Graney likes to say, and “even though we have this extra chef in the kitchen, it has worked out very well.”

The Path Ahead

While the TOTE containerships have garnered many of the recent headlines, NASSCO is perhaps best suited to build tankers and currently has eight tankers on its orderbooks, including for

**INNOVATE AND ADVANCE
A PATHWAY TO THE FUTURE**

AUSTAL IS IN SEARCH OF SPIRITED INNOVATORS LOOKING FOR THEIR NEXT CHALLENGE.

At Austal, it’s not just our aluminum multihull designs that make us stand out. We’re a dedicated Alabama workforce over 4000 strong, with international roots, redefining how the Navy builds warships. The same level of precision that goes into the construction of our advanced vessels also drives the cultivation of our outstanding team.

NOW HIRING:

- SENIOR MANAGER – VESSEL COMPLETION YARD
- CHIEF ELECTRICAL ENGINEER
- SCHEDULER
- NAVAL ARCHITECT
- DEPUTY PROGRAM ENGINEER
- PIPE WELDERS AND FITTERS
- WELDING PROCESS ENGINEER
- SUPPORTABILITY ENGINEER
- MANUFACTURING DATA ANALYST
- CONTRACT ADMINISTRATOR

AUSTAL FOR A LISTING OF CURRENT OPENINGS AND TO APPLY, VISIT WWW.AUSTALJOBS.COM

Austal USA shall abide by the requirements of 41 CFR §§ 60-1.4(a), 60-300.5(a) and 60-741.5(a). These regulations prohibit discrimination against qualified individuals based on their status as protected veterans or individuals with disabilities, and prohibit discrimination against all individuals based on their race, color, religion, sex, or national origin. Moreover, these regulations require that covered prime contractors and subcontractors take affirmative action to employ and advance in employment individuals without regard to race, color, religion, sex, national origin, protected veteran status or disability.

SEA-Vista a series of three ECO Tankers that last month started construction. SEA-Vista LLC is a joint venture between Seacore Holdings and Avista Capital Partners. The tankers on order are 50,000 dwt, measuring 610-ft. long with 330,000 barrel cargo capacity. The LNG-conversion ready Jones Act tanker series was designed by DSEC, a subsidiary of Daewoo Shipbuilding & Marine Engineering (DSME). The ECO MR tanker is designed for fuel efficiency courtesy of optimized hull design and the inclusion of the G-Series MAN ME slow speed main engine, dual-fuel capable with the ability to accommodate

the future installation of an LNG fuel-gas system and tanks.

The vagaries and uncertainties of shipbuilding and repair markets makes forward planning – for even the most seasoned veteran – part art, part science, part luck. When asked how long he sees the current run U.S. shipbuilding bull market, Graney was blunt; “if you would have talked to me two years ago, I would have told you that we would not build another tanker for five years or so. Well here we are today, and we have eight in the backlog.”

While the shipyard is filled and bustling with work, Graney figures that it

has not reached its capacity. NASSCO asked its DSME colleagues to evaluate yard ‘as is’ and, while the ship type mix is a critical factor in determining total yard output, “if we’re talking about product carriers, they think we could do nine ships per year. We have eight tankers in the backlog, and in 2016 we’ll deliver six tankers, and that’s the most we’ve ever done in our history.”

While the current situation is impressive, Graney and his colleagues are not likely to rest on their laurels, and he considers maintaining a strong, steady order book one of the chief challenges of his job. “My main challenge? How do

we sustain this. We have 11 ships in the backlog which will sustain us for three years, which is the longest time horizon apart from T-AKE that we’ve ever seen. When we’re building commercial ships, being able to see three years out is big,” said Graney.

“So the big challenge: We are hiring all of this fresh young talent, developing them rapidly, but it won’t mean anything if we don’t have work beyond the next three years to help retain them and their skills. How do we keep those guys gainfully employed in this business? That to me a challenge.”

He’s not alone.

Building for the U.S. Navy: While the MLP – Lewis B. Puller – is actually the third in the series, in some respects it has lead ship quality as it is designated MLP 3 / AFSB, the first to be equipped with a flight deck, a hangar and accommodations for about 250 people. **“The MLP is really like the Ford F150 pick-up truck; you can put anything you want in the bed; in this case we put a flight deck on it,”** said Kevin Graney.



Hempel: Born in Maritime

As Hempel approaches its 100th anniversary in 2015, Christian Ottosen, Group Marine Marketing Director, offers insights on the company's initiatives and drivers. Here's a hint: protecting ships at sea and protecting the environment.



Hempel was created 99 years ago as a specialist marine paints provider. Its founder, JC Hempel, was the first person to develop an antifouling product for a ship's hull. Although Hempel is now active in other paint sectors such as decorative and protective coatings, the company was born and bred in the shipping and the maritime industry, and 99 years later this remains at the heart of the company.

Today Hempel is a leading coatings supplier in multiple markets. From wind turbines and bridges to hospitals, ships, power stations and homes, Hempel's coatings are engineered to protect man-made structures from the corrosive forces of nature. Hempel owns, among other companies, Crown Paints.

With a focus on R&D, advanced production techniques and professional coatings advice, the company works around the globe to help keep its customers' investments safe and attractive for the long haul.

"Our working concept is simple: We are curious, creative and self-critical, and we always aim to create extra value for our customers," said Christian Ottosen, Group Marine Marketing Director. "Within the marine sector we offer a range of exceptionally high quality, certified products including fouling release systems and antifouling; and specialised coatings for ballast tanks, cargo holds, decks, topsides, superstructures and vessel interiors. In addition, we also supply certified potable water tank coatings. Through our network of 150 stock points, we can supply paints for on-board maintenance through almost every port in the world."

Looking Back

As is the case for many serving the global maritime market, lessening the impact of shipping on the natural environment is top of the agenda for all quality shipowners.

"I believe that the launch of

our new coating system HEMPA-GUARD plays an important role in enabling shipowners to operate their vessels in a more environmentally friendly way," said Ottosen. "Tests show that on average that HEMPA-GUARD reduces overall fuel use by six percent which not only saves expensive and finite fossil fuel but also reduces the amount of greenhouse gases emitted into the atmosphere. Additionally, HEMPAGUARD maintains its antifouling efficiency at both slow and fast speeds and is equally effective during idling periods of up to 120 days. This allows a vessel to steam at its most fuel efficient speed. HEMPAGUARD also releases 95% less biocide than traditional antifouling products. Taken together, the benefits of HEMPAGUARD allow a shipowner to make a significant improvement to its environmental footprint."

While 2014 was a year of development to meet emerging environmental and fuel efficiency ends, Ottosen said that the industry largely remains in recovery mode to this day. "The earlier phase of vessel over-ordering coupled with a global recession led to too many ships chasing too few cargoes and the subsequent collapse of freight rates. We are still recovering from that period, although I believe there is a glimmer of light at the end of what has been a very long tunnel."

While Ottosen sees some sectors turning the corner, conventional wisdom suggests that the levels of the over-inflated markets before the crash of 2008 will never be hit again. Rather, the expectation is a "new normal" of modest, but stable rates. But in the coatings market in particular, there is always a silver lining: "On the positive side for Hempel, the large numbers of vessels delivered between 2009 and 2011 are beginning to fall due for their first drydocking," said Ottosen. "This means that activity for marine coatings is buoyant and likely to remain positive for some time."

Planning Ahead

As an independent company with almost 100 years' experience in marine coatings, Hempel is a leader in its sector. The company continues to innovate and to bring new products to market through its 10 R&D facilities located across the globe.

Efficiency and environment are two words first off the lips of nearly every shipowner, and in regards to a company such as Hempel this is a strategic advantage.

"Delivering efficiency to shipowners will be central to our activities next year and beyond," said Ottosen. "Our hull coatings allow vessels to be more fuel efficient and to reduce their environmental impact. Our products can be applied quickly and cargo loading can commence shortly after application so dry dock periods are reduced. Further efficiency gains are generated through using our cargo hold coatings that lower maintenance costs and reduce cleaning times between loads. Even our global arrangements for delivering and managing a vessel's stock of sea paint reduces cost and handling times."

Central to Hempel's future will be the continued advancement of its hull coatings with five- to seven-year drydocking intervals. "Our focus will be on improving the HEMPAGUARD technology and enabling this silicon-based coating to be applied at low temperatures," said Ottosen. "This will give owners added flexibility over where and at what time of year the coating may be applied. We also plan to introduce a new cargo hold coating with a five-year drydock interval. This will be more durable, faster to apply and allow loading to commence more quickly after application." For newbuilds, it will launch an extensive series of uni-primers with PSPC approval for water ballast tanks, and its products will be suitable for all shipbuilding processes and will use fiber technology to ensure less cracking and enhanced durability.



"I believe that the launch of our new coating system HEMPAGUARD plays an important role in enabling shipowners to operate their vessels in a more environmentally friendly way."

**Christian Ottosen,
Group Marine Marketing Director**



Since 1927, The Damen Way



Damen is a ubiquitous name in global ship and boatbuilding, delivering its unique brand with customary style and flair from ports of call around the world. For insights on the company's long, colorful history and its bright future, we received insights from Arnout Damen, COO.

Like many great maritime stories, Damen has its roots, present and future intertwined in family ties. Current COO Arnout Damen is the son of Kommer Damen, Chairman of the Board since 1969, and grandson of Jan Damen, co-founder (together with his brother Rien Damen) of Damen Shipyards in 1927.

"We are a family company and we gain strength from that too," said Arnout Damen. "Inside the offices and the production halls you'll find a no-nonsense mentality and, even with 8,000 employees, a flat organization; doors are open. Our global presence is enhanced by our positive attitude and, armed with this mentality and a large portfolio of vessels and solutions, we serve almost any market. That, I think, makes us stand out: quality, capability, size and mentality."

There are many words to describe the Damen of 2014, but the first that comes to mine is 'diverse.' Damen Shipyards Group operates 32 ship- and repair yards. To date it has delivered more than 5,000 vessels in more than 100 countries, delivering approximately 160 vessels annually.

Damen is diverse in that it offers a wide range of products, including: tugs, workboats, naval and patrol vessels, high speed craft, cargo vessels, dredgers, vessels for the offshore industry, ferries, pontoons and super yachts.

Further, Damen is diverse in that it offers a broad range of services, such as maintenance, spare parts delivery, training and transfer of (shipbuilding) know-how, as well as a variety of marine components, especially nozzles, rudders, anchors, anchor chains and steel works.

Another equally apt term to describe the company is 'standardized.'

Based on its unique, standardized ship-design concept, Damen is geared to produce consistent quality. Damen's focus on standardization, modular construction and keeping up to 150 vessels in stock leads to short delivery times, low 'total cost of ownership', high resale value and reliable performance.

In fact Damen's focus on standardization extends far beyond marketing brochure fodder, and is in fact one of its fundamental corporate values

"Both our unique, standardized ship-design concept and our modular construction approach enable us to offer our customers well-proven vessels at competitive prices and worldwide, post-delivery support throughout a vessel's lifecycle," explained Arnout Damen. "Because we keep vessels in stock, the delivery time of a Damen vessel is very short; for some vessel types even as short as two weeks. Years of refining our production processes (engineering, hull fabrication, supply chain management) have resulted in fast response to customer requests; short delivery times; reliable performance; low total cost of ownership (and high resale value); and interchangeability of vessels, spares and equipment.

Standardization means even more at Damen, as Damen Technical Cooperation (DTC) concept enables its customers to build vessels locally, anywhere in the world. Damen provides all prefabricated ship components and can, on request, combine this with assistance, training and backup.

Increased Innovation

While many companies eye emerging regulations skeptically, Damen sees new rules, such as the move toward reduced emissions globally, as an opportunity. "This both provokes and ignites many innovations," explained Arnout Damen. "At Damen, this has, for example, resulted in the ASD Tug 2810 Hybrid (diesel-direct, diesel-electric, electric versions), an upcoming inland shipping vessel fueled on LNG (Ecoliner), an electrical patrol vessel for the canals of Amsterdam and, together with MTU and Svitzer, a research program as to an RSD tug fueled on Compressed Natural Gas (CNG). Continuous innovation is good for the worldwide maritime industry; it keeps us all on the edge and keeps the industry moving forward."

So far in 2014 Damen has enjoyed the benefit of generally buoyant markets, as Arnout Damen reports that "already our sales are up by 40% compared to last year."

Looking ahead, Damen sees its strategy of standardization as paying off, as Arnout Damen said "ever more customers in a growing number of countries see that

'standard', which is what we are good at, first and foremost means 'proven'. It also implies easy maintenance, and, by developing and innovating our vessels within a certain standard, other useful features are achieved, such as reduction of fuel consumption."

In an industry which has long lamented the need to build unique designs and features on every new vessel, the Damen standardized approach seemingly offers multiple benefits, particularly as new maritime rules and performance expectations evolve in tandem. "Answering the question: 'How can we make this vessel more fuel efficient?' or 'How can we give this vessel type better seakeeping qualities?' means that we don't have to design and build a completely new ship from scratch each time we develop a new innovation or are confronted with new rules and regulations," said Arnout Damen.

Innovation Going Forward

In inquiring about future innovation to be designed and delivered in 2015 and beyond, Arnout Damen was quite succinct in his answer: "A lot!" In addition to the expansion of its service hubs globally, Damen has a number of eye-catching designs on the drawing board. While there are far too many to include in this space, the three that we found most compelling include:

- Ecoliner: The ECO Liner 1145 is designed to measure 110 x 11.5 x 3.6 m with a deadweight of 3,100 tons and a maximum speed of 10.8 knots.
- Ballast Water Treatment Barge + other BWT solutions.
- Floating Tidal Energy Platform: Bluewater, Damen and Van Oord partner to realize a unique floating tidal energy platform.

Long History, Promising Future

"As we are an active member of the maritime industry and have been so since 1875 (when the Schelde naval yard was founded), this speaks for itself: it is extremely important to the whole of our company," said Arnout Damen when assessing the importance of this industry to his company. "At Damen, it's all about ships - it's what we do, it's who we are."

“Both our unique, standardized ship-design concept and our modular construction approach enable us to offer our customers well-proven vessels at competitive prices and worldwide, post-delivery support throughout a vessel’s lifecycle”

Arnout Damen, COO



The **PSV3300 World Emerald** on sea trial



ASD Tug 2810 hybrid



“Walk to Work” vessel



Damen Stan Patrol vessel

Air Products Gas Processing Solutions



APAS delivered the nitrogen generator for Prelude – the world’s largest floating LNG plant anchored 200 kilometers off of the coast of Australia. “The scope of this project was huge – larger than any system that had been delivered.”

Tom Cantero
Managing Director

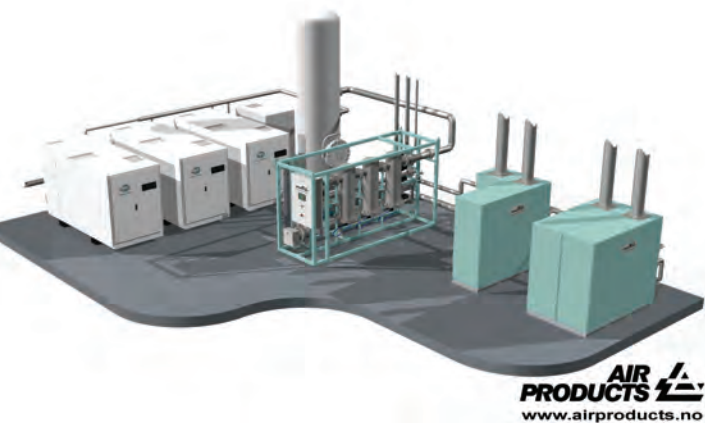

As the first company to commercialize hollow fiber membranes for air separation onboard ships, Air Products AS, Norway (APAS) is a true pioneer. Managing Director Tom Cantero discusses his company’s technology, developments and outlook.

A manufacturer of gas processing systems for offshore, shipboard and land-based use, APAS manages all facets of the membrane process, from basic research, system design, engineering and manufacturing, through installation and service.

Since the first membrane system was introduced by APAS in 1984, more than 1,000 membranes nitrogen systems have been delivered for a variety of shipboard applications in addition to more than 220 systems for offshore and petrochemical processing. According to Cantero, more than 15,000 PRISM membrane separation systems, the key component which generates the nitrogen required to make the systems function, are in operation or under contract globally. Every one of these were designed and built by Air Products AS, in Kristiansand, Norway.

APAS’ nitrogen gas production technology delivers high purity nitrogen using less feed air than many competitive systems, enabling customers in various industries and locations around the world to produce an economical on-site nitrogen supply. “Using our own, proprietary design provides unparalleled insight into the details of membrane nitrogen generation and ensures that customers receive an optimized and proven package,” Cantero said.

Over the years, the APAS product has been fine-tuned, gaining a reputation for reliability simplicity and low maintenance requirements. “We are committed to delivering standardized marine systems that are purpose-based and cost effective,” Cantero said. He explained that employing standardized designs saves time and expense across the organization, starting during the sales process and continuing through the after-sales business. “We can clarify customer queries more efficiently while presenting proven systems without the potential weaknesses of fully custom designs. The project manager saves time by using stan-

dard drawings and documents. In the supply chain, we are able to leverage financial benefits from purchasing greater quantities of components from fewer suppliers. Standardization also provides us the opportunity to brand several consumable parts, enhancing our after-sales business. Finally, standardization makes training easier so we can effectively establish and authorize local service agents to help ship owners in remote locations.” The formula has proven successful for APAS, as the company has reported double digit growth since 2000. 2014 was a particularly good year for the company which received its single largest order of PRISM Nitrogen systems for Shipboard applications of the last 30 years: in February 2014, APAS won a project from one world’s largest energy companies involving replacement of a competitor’s nitrogen systems in 25 liquefied natural gas (LNG) vessels with new Air Products PRISM membrane systems.

Also in 2014, APAS delivered the nitrogen generator for Prelude – the world’s largest floating LNG plant anchored 200 kilometers off of the coast of Australia. “The scope of this project was huge – larger than any system that had been delivered,” Cantero said. “The logistics of the project required us to disassemble much of the structure and then acquire specialized transportation to get the unit from our manufacturing facility, through town, to a port that was equipped to handle large assemblies. This project is something we are very proud of and we are anticipating building another similar system in the near future.”

And though APAS also serves markets outside the maritime space, offshore and maritime persist as the company’s mainstays. “In addition to offshore and process gas systems, for the Norwegian branch of Air Products, the maritime industry is and always has been the dominating segment,” Cantero explained. “Our

recent business performance in the marine industry has outpaced other business units in the corporation and has been recognized at the very highest levels of management for outpacing the greater economy. The APAS business unit is anticipating a thriving market in maritime business for the foreseeable future.”

“This year has been very positive for the shipbuilding industry as far as contracting of new vessels. The marine industry is recovering from the setbacks related to the financial crisis of 2008, and the resulting economic recession and is fully in a growth cycle,” Cantero said. “I see positive growth in several areas of the marine industry with opportunities for APAS to supply gas generation assemblies into new markets.” According to Cantero, solid growth in the oil and gas sector is driving near-term expansion across many segments as the need for nitrogen blanketing and inerting is strong in most aspects of petroleum exploration, production, refining and transportation. Cantero said longer term growth is driven largely by several new regulations for inerting cargo holds and requirements for greener ships that drive new business opportunities for APAS products: “Shipbuilders and operators are continually seeking more energy efficient components. The operating costs associated with compression, and the energy demands of ancillary equipment, are becoming key factors in purchase decisions.”

Building off of established success and a positive outlook, APAS is presently reorganizing its business with a focus on speed and local accountability. “This new structure is providing each business area autonomy and freedom to react quickly to market conditions. As with many large corporations, working through the layers of management can increase the time it takes to affect change or address market shifts, and we have had to manage these types of demands in the past,” Cantero said.

Alfa Laval: Keeping it Clean



Forced by regulation to clean up, ship owners have never been so keenly aware of the exact emissions coming from their ships. And when it comes to cleaning up, Alfa Laval is there every step of the way, as Peter Leifland, President, Marine & Diesel Division, Alfa Laval, explains.

Alfa Laval can be found on many ships worldwide, at work with a wide variety of applications and processes. As a global supplier with a full network of service and support, it provides strong technical competence in diverse areas, including: separation, filtration, fuel conditioning, heating and cooling, desalination, ballast water treatment, tank cleaning, inert gas generation, steam generation, waste heat recovery, oily waste reduction and exhaust gas cleaning. Alfa Laval's job: within these areas, optimize processes, save energy and reduce emissions by providing equipment, systems and competence.

While the word 'innovation' is arguably used too often and too loosely, this is not the case with Alfa Laval, which historically has positioned itself on the leading edge of innovation, offering ship owners solutions to what are becoming increasingly complex emission and environmental problems.

"In the autumn of 2014 we launched the next generation of the Alfa Laval PureSOx exhaust gas cleaning system," said Leifland. "PureSOx enables ship owners to comply with IMO's sulfur emission cap in Emission Control Areas (ECAs) while using economical HFO, rather than switching to expensive distillate."

PureSOx 2.0 builds on the existing PureSOx, which include 98% SOx removal, up to 80% removal of particulate matter (PM) and hybrid operation with either seawater or circulation water. These are combined with new enhancements leading to greater compactness and flexibility. Among them are a 15% smaller scrubber diameter, greater modularity in the water cleaning unit, powder dosing, noise attenuation and the ability to handle exhaust gas from both engines and boilers.

"We have also seen an increased interest in our Automated Fuel Changeover System (ACS)," said Leifland. "This is another solution

for meeting the game-changing ECA legislation, which takes effect January 1, 2015."

The Alfa Laval adaptive fuel line was launched at SMM in Hamburg this year, and is designed to take a holistic approach to fuel optimization and engine protection on oceangoing vessels, to deliver energy efficiency (fuel savings), enhanced cat fine removal, fuel quality assurance, multi-fuel flexibility and safety in ECA compliance, all in one integrated system.

"The Alfa Laval adaptive fuel line fully integrates the fuel oil treatment separator systems (ALCAP) with the fuel oil conditioning systems (FCM One) and the fuel recovery system (PureDry)," said Leifland. "The integration is completed with control systems and a CatGuard monitoring system for cat fines. This combination of feed optimization, effective fuel management, system supervision and waste fuel recovery can provide fuel savings of 2-4%, plus additional savings through reduced engine wear and the prevention of breakdowns due to cat fines." While the company invests mightily in R&D, it is also a consolidator. Case in point is the acquisition of Frank Mohn AS, a company Alfa Laval was following closely for several years.

Riding the Wave

While innovation is necessary in the maritime market with the growing glut of regulation, the need for new technology is tempered with depressed freight rates and low shipbuilding prices that have put a lot of pressure on the maritime industry.

"Due to lack of earnings, some ship owners have had to defer essential maintenance and limit operational efficiency upgrades to those with a payback of less than 2-3 years," said Leifland. "Shipyards have also had negative earnings due to the excess yard capacity and low ship prices over the last couple of years. On the flipside, the marine supply chain

has tried to be more innovative in developing energy-efficient products that reduce vessel operating costs, as well as solutions to meet the increasingly stringent and widespread environmental regulations. Korean and Japanese yards and European equipment manufacturers have led the way here."

Looking ahead to 2015, the need to comply with increasingly stringent and widespread environmental regulations will mean continued demand for NOx, SOx, BWT and multi-fuel solutions. And the trend towards energy efficiency in the maritime industry will continue, in earnest, driving Alfa Laval's waste heat recovery and waste fuel recovery solutions in the years ahead.

"We see an increased interest in our Fuel Management Course, which is conducted around the world by our Alfa Laval service organization together with VPS (Veritas Petroleum Services)," said Leifland.

Going forward Alfa Laval will continue the development of multi-fuel solutions, and it is exploring ways to support the combustion of fuels such as LNG, LPG, methanol and DME in the engines and boilers of ships.

Investment in the Future

Alfa Laval is a global company whose heat transfer, separation and fluid handling experience are applied in a wide range of industries. Yet it has a specific Marine and Diesel division with a dedicated industrial focus. Alfa Laval is investing in R&D, primarily so it can respond to changing customer needs with new products and improved versions of existing solutions. A prime example of this is the new Alfa Laval Test & Training Center in Aalborg, Denmark, which is a virtual ship on land with a 250 sq. m. testing area, where the company can also identify new areas of application for existing products and key technologies, which is another important means of achieving profitable growth.



"PureSOx enables ship owners to comply with IMO's sulfur emission cap in Emission Control Areas (ECAs) while using economical HFO, rather than switching to expensive distillate."

**Peter Leifland,
President, Marine & Diesel Division**



R.W. Fernstrum: Keeping it Cool



“Overall, 2014 has been a positive year for Fernstrum,” said Sean Fernstrum. “There is still growth in the U.S. offshore market; a positive for many in the industry. We have seen growth in other segments as well, tank barges and alternative energy.”

**Sean Fernstrum
President & Owner**

Founded by Robert W. Fernstrum 65 years ago, R.W. Fernstrum & Company is now run by the third generation of Fernstrums who continue to build and extend its commercial marine heat exchanger business. Sean Fernstrum, President & Owner discusses the future.

R. W. Fernstrum & Company is a third-generation, family owned business that manufactures heat exchangers, primarily for the commercial marine industry. In addition to its GRIDCOOLER line of keel coolers, it also manufactures and sells Weka Boxcoolers in the Americas and Tranter Heat Exchangers.

“The origins of our product lines have been a foundation for our success,” said Sean Fernstrum, current president and an owner of R.W. Fernstrum & Company, in assessing the creation of the company by his grandfather 65 years ago. “The GRIDCOOLER Keel Cooler was developed to solve a cooling problem for landing craft during WWII. My grandfather, Robert Fernstrum, was the chief engineer at Gray Marine and Continental Motors during the war. Gray Marine built landing craft and needed to devise a compact closed-circuit cooling system to meet the needs of a wide range of operating conditions. Existing cooling systems were far too large for landing

craft, so Robert developed a solution on his own. His compact keel cooler was the prototype for what would become our GRIDCOOLER Keel Cooler line.”

R.W. Fernstrum also offers the Weka Boxcooler, which was a development of Cees de Kwant in the Netherlands. After reviewing the construction of existing box coolers in the industry, Cees saw the inherent weakness in the materials being used in box cooler construction. His solution was to utilize a material that had proven itself in decades of use in other products working in the same environment: copper-nickel. His use of this material and innovative creation of easily applied protective devices make this product line stand out. In addition it offer Tranter’s line of heat exchangers that go back to Ransom Olds and his development of chilled plates used in milk wagons 100 years ago. Today those plates are providing efficient heating of cargo in applications like petroleum and sulfur barges. Tranter Heat Exchangers also provide cooling in applications like live wells on commercial fishing boats. These heat exchangers along with various plate and frame offerings allow Fernstrum to provide a wide variety of solutions to its customers.

2014 & Beyond

“Overall, 2014 has been a positive year for Fernstrum,” said Sean Fernstrum. “There is still growth in the U.S. offshore market; a positive for many in the industry. We have seen growth in other segments as well, tank barges and alternative energy. The changes in the engine tier ratings have been a challenge over the last few years; but we are adapting.”

Looking ahead the company sees plentiful opportunity. Particularly, the emerging inland market segments and existing offshore segments are at or near capacity for the near future, signs that 2015 along with the next few years should be good for

the U.S. commercial marine market.

Innovation to Come

Fernstrum will focus on reintroducing the Tranter Platecoil line to the inland marine market; a product line that the company represents in the marine industry. “Platecoil is proving to be an efficient, cost effective heating solution for barges and bulk cargo vessels,” said Sean Fernstrum, “and we are looking to reintroduce this solution to a wider audience in the upcoming year.

When evaluating the innovation coming from his Menominee, Mich., shop, Sean Fernstrum lays the credit to the company’s employees in executing the vision, year in, year out. “I think our commitment to a hardworking and knowledgeable employee base along with a focus on problem solving are two of our greatest strengths,” said Sean Fernstrum. “It is a formula for success that has proven itself for decades. We sell solutions, not just a product. Our customers’ relationship with us doesn’t end with a signed purchase order, that’s just the beginning of what I hope will be a long and mutually beneficial relationship.”

While the company’s core product line was born out of combat necessities created in World War II, the company’s focus for decades has been the commercial marine industry. Starting with shrimp boats in the Gulf of Mexico back in the 1950s, it quickly moved to push boats, tugs and other commercial vessels. While it does have land based applications, the commercial marine industry is clearly the market driver for the company.

“The maritime industry is our home,” said Sean Fernstrum. “Over the years, the hardworking people in the industry have become our friends, family. We spent hours working on projects to come up with reliable solutions for their applications. It is our customers that allow us to continue to strive in the industry.”



Photo: Edison Chouest

MAN Diesel & Turbo: Power Play

MAN Diesel & Turbo has developed a lead in the supply of modern engines with dual fuel capability. Here we speak with the company's Ole Grøne, SVP, Low-Speed Promotion and Sales, for his insights on the company's future trajectory.



Simply put, MAN Diesel & Turbo is all about power with one of the world's premiere line-up of product, services and systems. The company invests regularly and mightily in R&D to ensure that it is on the leading edge of power solutions.

"We place a particular focus on R&D and see the refinement of our existing technology and, especially, the introduction of innovation to the diesel concept, as the only way of assuring our future," said Grøne. "A great part of our current strategy is the expansion of our dual-fuel concept and the development of engines that satisfy every industrial niche and have the potential to run on a growing variety of fuel types."

Case in point is the company's lead position in the supply of engines fuelled by LNG to power a burgeoning fleet of new ships, a development that will help ship owners to dramatically reduce emission while potentially saving fuel costs.

"Looking back at 2014, I think MAN Diesel & Turbo's primary success within the low-speed market has been the very positive development of our low-speed, dual-fuel ME-GI engine," said Grøne. "Since its introduction it has really captured the market's imagination with the result that our order book now stands at over 70 units with more, identified orders to come."

The year 2014 was also significant as it saw the completion of the first ME-GI unit at Doosan with a successful Factory Acceptance Test confirming the viability of the ME-GI concept. The ME-GI has added important references such as the first gas-powered car carrier for United European Car Carriers. Another important reference includes the expansion of the number of fuel types that the ME-GI can run on to include ethane, and in a variant of the GI concept, the LGI engine using methanol and, later, LPG.

Companies such as MAN Diesel & Turbo are an excellent bellwether

of the overall market in general, and signs point to a sustained market. "Our Two-Stroke licensee reported that the order book for low speed engines has obviously slumped since its historic peak in 2009 but 2014 showed a determined upturn in the curve and a definite, positive trend," said Grøne. "Simultaneously, in terms of manufacturing, there is still plenty of two-stroke engine capacity. Therefore, overall, I think we can only be positive about the future. However, regulatory changes, triggered by enhanced environmental awareness in the marine market calls for an even more intensified and costly development effort."

Looking Far Forward

With large, capital intensive systems such as propulsion, long-range planning is as critical to success as near-term performance. "We are looking ahead to 2015 but, of course, also much further forward than that," said Grøne. "If, as predicted, the world commercial fleet is to grow by 100% over the next 20 years, than this means 1,500 - 2,000 new ships will be added every year, which means some 25,000,000 more kW will need fuel every year. The big question arising from this is: which fuels and what technology?"

Obviously, the Tier III emission regulations for NOx and SOx now to be enforced in the North American NECAs and in SECAs are going to have a major effect on the marine market. "Through primary measures and refinement of our existing diesel technology, our entire engine portfolio has already been Tier II-compliant for several years," said Grøne.

However, to meet the even stricter Tier III requirements, secondary measures will be necessary.

"Fortunately, we already have the necessary technology in place, much of it integrated within the engines, and I am confident that the market will take even more to our solutions than they already have. Primary

among these are our SCR (Selective Catalytic Reduction) and EGR (Exhaust Gas reduction) systems for NOx control. Implementation of these on board will be a major task in the future for the industry," said Grøne. In the coming year, MAN Diesel & Turbo has no major new product introduction imminent, rather it will continue on its path toward developing and refining its power products to meet immediate needs and long-range projections. "I would say that the intention is not so much to introduce further, new products or services but, rather, to continue rolling out what we have already set in motion," said Grøne.

"We expect the order for the 100th ME-GI engine to be announced during 2015. Our G-series of engines, characterized by their significant contribution to lower CO2 emissions, will also shortly reach order number 1,000 less than five years after first being announced. The ever-expanding fleet of engines of our design will be looked after by MAN PrimeServ, our after-sales division, who will also be kept busy by a number of significant projects involving the conversion of two-stroke, HFO-burning engines to dual-fuel running following the ME-GI concept, and other large retrofit projects for applying new technologies to the existing fleet."

For the increased retrofit activity anticipated at PrimeServ, the company developed a host of products, the most recent from this year being MAN EcoCam. The EcoCam is a hydraulically controlled, variable exhaust-timing solution that enables a variable cam profile without any mechanical modification of the camshaft. When it is active, the engine can run at a lower load with reduced fuel consumption. It can also be deactivated whenever necessary, allowing the engine to run at full load. We also expect an increased activity in replacing older propellers with the more efficient, MAN Kappel-designed propellers.



"A great part of our current strategy is the expansion of our dual-fuel concept and the development of engines that satisfy every industrial niche and have the potential to run on a growing variety of fuel types."

**Ole Grøne,
SVP, Low-Speed Promotion and Sales**

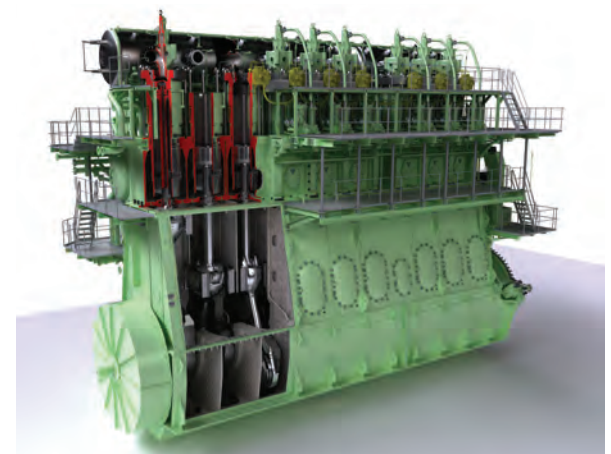

MLS: eLearning Re-thought



“Our biggest contribution to date is adaptive learning which makes vessel familiarization standardized, rigorous, measurable and efficient.”

Murray Goldberg
CEO

Marine Learning Systems, an eLearning software and services provider, delivers interactive, customized maritime training with a key focus on safety and performance improvement. Company founder and CEO Murray Goldberg explains.

“Creating technologies that improve training outcomes” is Murray Goldberg’s professional passion. A relatively new tool in education, eLearning has gained acceptance as an effective means for knowledge acquisition in many educational and industrial fields. For the maritime sector in particular – which is at times notoriously reluctant to adapt new technologies – eLearning has picked up steam within the last several years as its effectiveness for training and safety are increasingly proven.

Helping to lead this push is Marine Learning Systems. To say the company’s scope is massive would be an understatement. Since its founding in the mid 1990s, the group has grown to serve more than 14 million students at some 4,000 institutions in 80 countries.

Marine Learning Systems, which develops eLearning software called Marine Learning Management System (MarineLMS), aims to help owners and operators deliver and manage critical maritime training and assessment. Notably, the company does not sell training courses, though it works alongside companies that do. Instead, the company provides the software that delivers the eLearning and measures training success so that it may be continually improved.

MarineLMS delivers training courses developed by the customer organization, procured from a maritime eLearning publisher or built by Marine Learning Systems’ instructional designers in concert with specific subject matter experts. The desired outcome for eLearning is no different than that of traditional maritime training: more extensive crew knowledge, improved safety and better operational results; the difference lies within its delivery. “We understand eLearning, its strengths and how it can be implemented to achieve greatly improved learning, and therefore safety and performance,” Goldberg said.

One way MarineLMS achieves optimal results is through its use of adaptive learning to directly customize the training and testing to each learner. Each trainee receives an eLearning “textbook” specifically customized to his or her job, equipment and vessel. MarineLMS makes vessel-specific and equipment-specific training standardized, rigorous and measurable, doing so with unprecedented efficiency, Goldberg explained.

MarineLMS provides features to manage competencies and support, assess, nurture and mentor employees as they enhance skills and progress their careers. Additionally, MarineLMS offers metrics and analytics that allow training managers to continually measure and report on training programs’ success, enable training to be continually adapted and improved.

“Our biggest contribution to date is adaptive learning which makes vessel familiarization standardized, rigorous, measurable and efficient. Typically, job shadowing is one of the primary means of providing vessel-specific training. This is unfortunate because the results are often quite poor, impossible to standardize and impossible to measure. This is unacceptable for any safety-critical industry,” Goldberg said. “MarineLMS brings a data-driven approach to training management, allowing training decisions to be based on data, not speculation.”

Another notable feature making eLearning a more attractive option are MarineLMS’ Remote Training Servers (RTS) used to replicate full land-based LMS experience on board, regardless of the state of internet connectivity. Trainees can move from shore to vessel, or from vessel to vessel seamlessly, using the same learning environment.

As the industry continues to pick up on the value of eLearning, Marine Learning Systems gains increasing success. “From our training-centered

focus, 2014 was an incredibly positive year,” Goldberg noted. “The level of discourse on training topics in the industry become more sophisticated. Operators, even the more traditional ones, are beginning to understand that we can improve our training by analyzing the successes in other industries and adapting those that are relevant to our industry. We are seeing that modern, data-driven approaches to training can have tremendous benefits.”

Goldberg said he expects the success to continue in the years to come. In addition to continued development of the company’s core products, 2015 will see the launch of a mobile training app to address increased smartphone use and subsequent opportunity to extend the reach of training without extending the cost.

“This is huge,” Goldberg said. Since MarineLMS is already built as a modern application with responsive design for tablets and smartphones, the move to an offline app is a logical next step.”

And going forward, the focus remains on quality. When asked about the defining trends that will drive Marine Learning Systems in the coming years, Goldberg said, “The overarching trend is the ever-increasing focus on the need for quality, not quantity, training and employee development.”

He explained that the increasing role in safety, efficient performance, employee satisfaction and company profitability means more thought will be put into training, generating even better outcomes, often with less time and smaller budgets, all playing into the hands of Marine Learning Systems. “We view knowledge and expertise as a core foundation of our business,” Goldberg said. “Our advantage is our eLearning knowledge and the experience our principle employees have in implementing eLearning.”

To our twelve "75th Anniversary" sponsors, our advertisers, our subscribers & our friends, we would like to simply say:

Thank You!

**MARITIME
REPORTER
AND
ENGINEERING NEWS**
MARINELINK.COM

AIR PRODUCTS

Pioneering nitrogen
membrane technology
worldwide

www.airproducts.no

VULKAN COUPLINGS



Photo credit: LCS2

Your source for premium power transmission solutions for Marine, Industrial and Construction Equipment applications in North America (including Canada and Mexico), the Caribbean and now countries of Central America and parts of South America including the nations of Columbia, Ecuador, Peru and Venezuela.

American VULKAN Corporation
Ph: 863-324-2424 | info@vulkanusa.com | www.vulkan.com

TRANSAS

ECDIS is not enough for me.
ECDIS alone isn't enough to be compliant; official charts and training are mandatory too. I work with a company that has it all. Transas has spent over 20 years refining the world's best ECDIS solutions. Find all the answers at ECDISfit.com

Transas Marine.
The world's number one in ECDIS



ECDIS • CHARTS • RATS • RAYS • TRAINING • ETC.



Vessel Operators Are you providing your officers and crew with the most **advanced, effective** and **efficient** vessel-specific job training possible?

MarineLMS is proving to be a game-changer in terms of our learning culture

Jeff Joyce,
Director, Fleet Operations,
British Columbia Ferry Services, Inc.



Marine Learning Systems
www.MarineLS.com • 1.855.E.MARINE

Welcome aboard



www.alfalaval.com/marine



MAN

MAN Diesel & Turbo

**LEADING THE WAY
FOR MORE THAN 150 YEARS**



HAMMAR
BETTER SOLUTIONS FOR SAFETY AT SEA

www.cmhammar.com

DAMEN

Kidde Marine

FIRE SUPPRESSION SYSTEMS

Since 1917



WWW.KIDDEMARINE.COM

ECS CLEAN AGENT SYSTEMS

- Safe for Occupants
- Rapid Extinguishment
- Minimal Damage
- Electrically Non-conductive
- Minimized Vessel Downtime
- Environmentally Responsible
- Globally Accepted & Supported

CARBON DIOXIDE SYSTEMS

- Superior Suppression
- Time-tested

WHDR GALLEY PROTECTION

- Rapid Extinguishment
- Proven Performance

ENGINEERED COOLING SOLUTIONS.

Over 65 Years Cooling The Marine Industry

FERNSTRUM
R.W. Fernstrum & Company

906.863.5553



GRIDCOOLER
Keel Cooler

WEKA
Boxcooler

Tranter
Heat Exchangers

HEMPAGUARD

First industry satisfaction guarantee on hull coatings

Find out more at hempaguard.hempel.com

HEMPEL

NEW ActiGuard Technology



VARD
a Fincantieri company



built on trust

JEFF LOGGIANO



PIETER SCHELTE



CSCL GLOBE



AL KOUT



NEIL ARMSTRONG

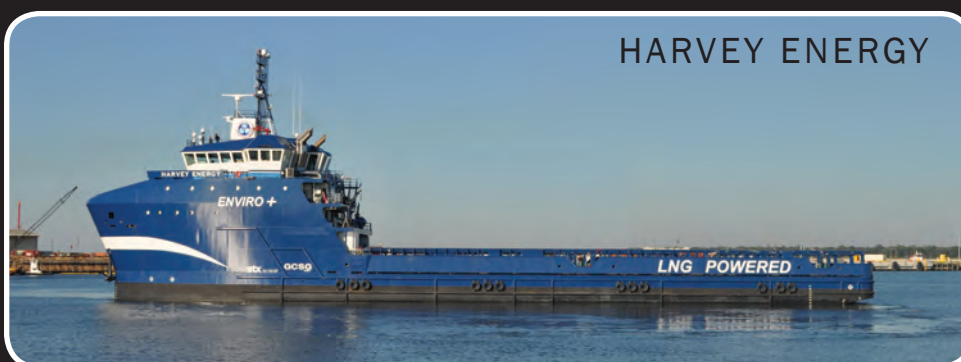

HARVEY ENERGY



CSAV TYNDALL



TOPCORAL DO ATLANTICO



HARVEST LEADER



ZEROCAT 120



LINDA OLDENDORFF



2014

**The World's Largest; the World's First;
(arguably) the World's Cleanest ...
"Great Ships 2014" has raised the bar high.**

The December edition is the traditional "Great Ships" edition of *Maritime Reporter & Engineering News*, and in 2014 we present 17 ships that cumulatively constitutes one of the strongest groups ever. If there were but two words allowed to describe the group of 17 (actually, 18 if you count the "Great Concept" from Lindenau on page 56), those two words would be "Big" and "Clean."

Build Big

To put it simply, ships are getting bigger, and here we feature two of the biggest ever in Pieter Schelte, Allsea's new decommissioning vessel and PLSV on page 42. This unique vessel is mammoth, at 1,253 ft. (382m) long and 407 ft. (124 m) wide and purpose designed for the removal of offshore rigs. CSCL Globe is the world's new title holder of "World's Largest Containership," weighing in at 1,312 ft. (400 m) long, 187,541 gt and capable of carrying 19,000 TEU. The boxship business in particular has been stoking the fires of the build big boom, as the economy of scale and efficiency of the mammoth ships are required to stay competitive in today global containershipping business.

Run Clean

While ships and boats grow larger, they also are much cleaner by comparison. Case in point is the push toward hybrid propulsion solutions as seen in Semper Fi (p. 47), Zero Cat 120 (p. 53), and 'LNG as Fuel' as seen on Harvey Energy (p. 45) and the pair of TOTE containership newbuilds, as profiled not in the Great Ships section but on p. 24 where we profile the work of Kevin Graney and his colleagues at NASSCO. The first LNG-fuelled TOTE containership is due for delivery in the Spring of 2015, so watch this space next year for a report on that ship in Great Ships of 2015.



Al Kout *Environmental, Piracy Protected, Proven*

The KOTC operated crude oil tanker Al Kout is the fourth sister Very Large Crude Carrier (VLCC) of 317,300 DWT, part of the KOTC Phase III of the fleet newbuilding projects. The vessel has been designed and built under the survey of NK class and distinguished in the register by the following notations: NS*(CSR, TOB, PSPC-WBT) (PS-FA) (ESP, PSCM, IWS) (EA, BWTS, HMS,

BRS1), MSN*, M0, Prime Ship-Hull care.

According to the builder and the owner, the tanker Al Kout offers many advantages over traditional tankers in terms of efficiency, environmental friendliness, crew comfort and security.

In regards to the vessel's hull form, it has a fully welded flush upper deck, a raked stem with a bulbous bow, a tran-

som stern with open water type stern frame, a semi balanced rudder and a fixed pitch propeller, directly driven by a slow speed diesel engine. In terms of propulsive efficiency, the vessel is equipped with a high diameter propeller and a propeller duct, designed by DSME, which reduces the energy losses of the propeller and improve the propeller's performance against cavitation. The

vessel has minimum 25 years of design fatigue life for hull part only based on the North Atlantic wave environment according to the rule of CSR, with cargo specific gravity of 1.025.

The ship is powered by a two stroke, electronically controlled main diesel engine, meeting the latest Tier II NOx emission standards, which provides the ship with easier and more effective engine control, reduced fuel and lubricating oil consumption and higher efficiency. The turbo chargers of M/E takes fresh air from atmosphere directly through a Direct Air Trunk (DAT) by which air at lower than engineroom (E/R) temperature is used for better efficiency of the turbo chargers. In addition, a novel waste heat recovery system is fitted on board Al Kout, which uses waste heat from main engine exhaust gases, which are fed to the exhaust gas economizer for the production of steam. The steam then is turning a two stage (High and Low Pressure) steam turbine, which in turn drives an alternator for electric power generation. The turbo generator can then

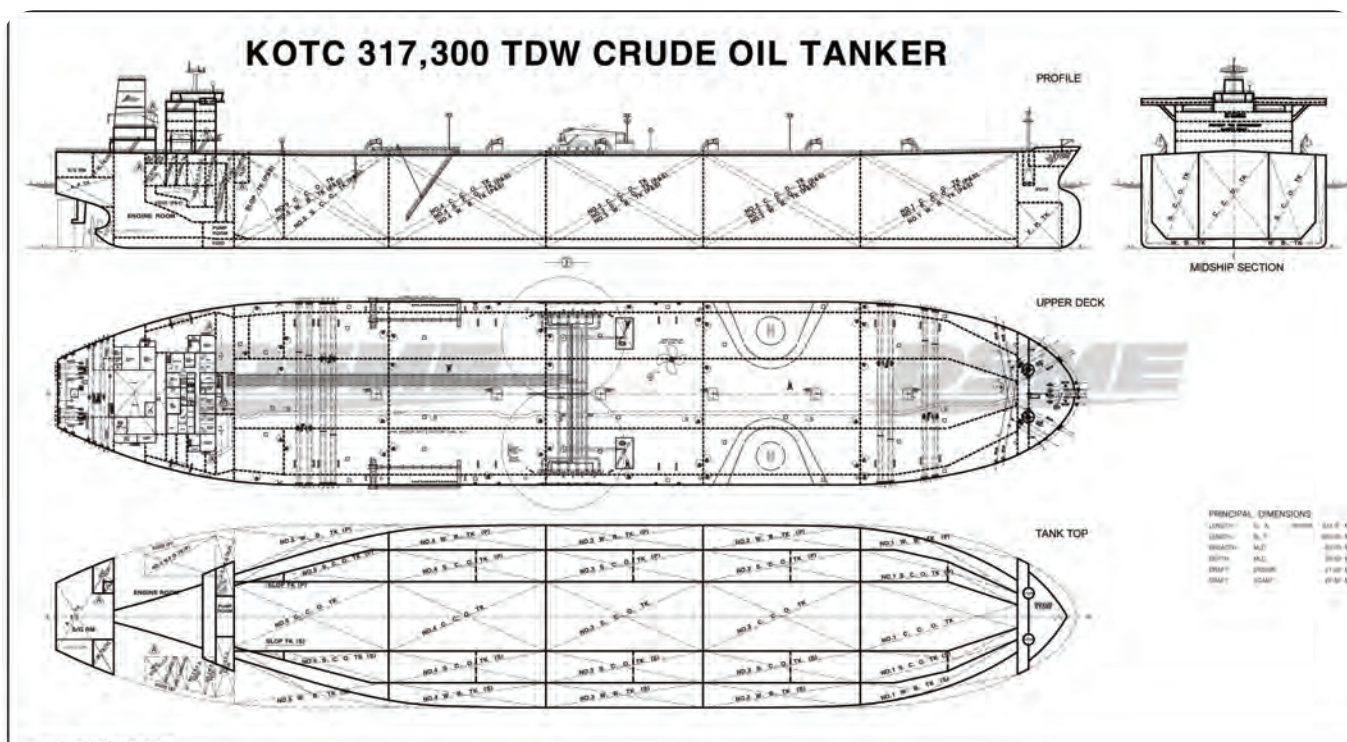

Photos: Allseas

Al Kout Main Particulars

Type	Crude Oil Tanker
Shipyard	Daewoo Shipbuilding & Marine Engineering Co., Ltd. (DSME)
Owner	KOTC, Kuwait
Length o.a.	1092 ft. (333m)
Beam	196.8 ft. (60m)
Depth	100 ft. (30.5m)
Tonnage (dwt/grt)	317,300
Flag	Kuwait
Classification	NK
Engines	Wärtsilä 7RT-flex 82T x 1 set, 27,390 KW x 72.0 RPM (MCR)
Propulsion	24,650 KW x 69.5 rpm (NCR)
Speed, service	16.2 knots
Daily fuel consumption	97.4 tons/day
Cargo volumn	357,000 cu. m.
Bunkers, Heavy oil	8,300 cu. m.
Bunkers, Diesel oil	1,000 cu. m.
Water ballast	97,500 cu. m.
IMO No.	9653434
Cargo tanks	15
Cargo tank coatings	Hempel
Cargo pumps	Shinko
Ballast control system	Shinko
Water Ballast Treatment	Panasia
Fire extinguishing system	Wilhelmsen (Unitor)
IBS & Radar	L3 Marine
Officers	17
Crew	21

be run in parallel with the other two diesel generators, forming the vessel's power generation plant. The turbo generator also has the ability to operate with direct steam generated from the auxiliary boilers in case that the main engine load is low or when the M/E is stopped. The heat from M/E air cooler is used to heat the Feed Water for WHRS system adding to overall energy saving. Further the condensate from T/G vacuum condenser is pre-heated by M/E jacket water cooling system before returning to cascade tank.

KOTC has ordered the vessel with several improvements in the field of electric power consumption. More specifically, an energy saving system (ESS) is installed on board the ship, a system which uses a variable frequency motor drive (inverter) for each main cooling sea water pump to reduce the motor power consumption by varying the frequency of the motors according to the cooling capacity requirements. The accommodation air condition system blowers are also provided with variable frequency drive to optimize room temperature while saving as much energy as possible. Additionally, the full accommodation area is fitted with LED type lights for improved illumination and reduced power consumption and the normal lights in E/R is designed to switch off automatically when the E/R is in unmanned state.

The environmental friendly character of the vessel has been a top priority at all stages of design and hence KOTC has taken the initiative to install a Ballast Water Treatment System (BWTS), which uses filtration and UV disinfection technology to minimize the impact on the local marine ecosystems.

In addition, the vessel is equipped with a Volatile Organic Compounds reduction system (De-VOC) to minimize the generation of volatile organic compounds, especially at the initial stage of cargo loading. The selection of the Wärtsilä RT-flex main engine, diesel generator engines and waste heat recovery system further reduce the exhaust gas emissions from the vessel and thus reduce her carbon footprint. The vessel's main engine and diesel generator engines emissions are continuously monitored by the emission monitoring system fitted on Al Kout, using sampling probes installed on each exhaust gas piping. A bio-oil based stern tube lubrication system is used for making the vessel more eco-friendly. The vessel is built ready for using fuel oil with 0.1 % sulfur to meet the upcoming stringent SECA requirements. It is worth noting further that KOTC have gone into minute

details for protecting the environment by installing a VOC Control (VOCON) system to control and minimize VOC release during the passage of the vessel.

On the ship's security and anti-piracy front, the vessel is provided with all the latest technology against piracy. Specifically, the long range anti-piracy measures include an innovative acoustic hailing device, which is used to deter and delay any attacking pirate boat by transmitting directional sound waves towards the attacking boat, after broadcasting warning messages. Short range measures consist of portable high pressure water jet cannons, anti-intrusion barriers (AIB), secure accommodation arrangement (enclosed ladder trunks at both port and starboard) at all possible accommodation accesses and designated citadel area with emergency communication equipment.

The surveillance of the spaces on board as well as in the vicinity of the vessel are monitored by a CCTV system at three control positions, which includes 16 cameras installed at key positions.

In addition to technical outfit, Al Kout – per MLC 2006 – is well outfitted for crew comfort. Among others, the crew can enjoy an indoor swimming pool with pyramid shape glass roof, sauna, large and fully equipped gymnasium and sports room, high speed broadband internet connection, on board entertainment system and satellite television. The accommodation spaces are also selected and constructed to a very high standard with spacious cabins and communal areas.

The ship features a centralized control, alarm and monitoring system (CAMS) includes more than 1,800 monitored parameters, instantly providing the engine and deck officers with all necessary information and adequately protecting all machineries on board.

An oil mist detector system is incorporated in E/R to continuously monitor and detect all strategic areas in the engine room for any possible mist formation. Provisions have been made for the easy retrofit of an alternative marine power (AMP) system at any future stage, which will allow the supply of the total necessary electric power from shore while at port. Another noteworthy design feature of Al Kout is that all equipment in accommodation spaces and control stations (engine control room, cargo control room, wheel house) are designed on the basis of ambient temperature of 45o C, while alternators, motors and cables in engine room are designed and manufactured on the basis of ambient temperature of 55 degrees C.

GEA



Partners In Protecting the Environment

E-series separators from GEA Westfalia Separator are successfully being used by the shipping industry for treating bilge water in accordance with IMO and Coast Guard requirements.

- High capacity, continuous and unsupervised operation
- Automatic adjustment to fluctuations in oil and sediment content
- Highest separation efficiency (less than 5 ppm)
- Compact size and low maintenance requirements with no chemical requirements

If our ready-to-connect systems sound better to you than high maintenance static separators, filters and chemicals, contact Frank Kennedy at 201-406-9570 or Francis.Kennedy@gea.com or visit us online at www.wsus.com.

GEA Mechanical Equipment US, Inc.

GEA Westfalia Separator Division

Toll-Free: 800-722-6622 • 24-Hour Technical Help: 800-509-9299
www.wsus.com

engineering for a better world

1943H

Pieter Schelte *Allseas' New Decommissioning Vessel & PLSV*

In a word, Pieter Schelte is BIG. Founded in 1985, Swiss-based Allseas Group S.A. is specialized in offshore pipeline installation and subsea construction. The company employs more than 2,500 people worldwide and operates a fleet of specialized, in-house designed and developed pipelay and support vessels. The company is known for its daring and imagination in ship design and technological innovation. Fittingly, its unofficial moto is “No guts, no glory”.

The newest Allseas vessel, Pieter

Schelte, is a huge ship, composed of two super-tanker hulls connected by a wide central work platform or slot, much like a catamaran. It will be able to remove topsides with one lift and move them to new destinations, meaning a large decommissioning job could be done in a fraction of the time it takes to do the job using traditional methods, a feat unheard of in large decommissioning projects. “Ever since we started designing Pieter Schelte long ago, we always knew there was a league of about 13 very large platforms in the Northern North Sea we could never take

out,” said Edward Heerema, Allseas’ Owner and President.

The specifications of the Pieter Schelte, are impressive, at 382m (1,253 ft.) long, 124m (407 ft.) wide, with a slot width of 59m (193.5 ft.) and a total width of 124m (407 ft.), making it almost as long as the Empire State Building is tall and wider than the length of a football field. The ship cost around \$3.1 billion to build and is powered by 11.2 MW engines connected to 12 Rolls Royce 5.5 MW thrusters. The large amount of thrusters is vital in allowing the massive ship to turn in a

short radius, compared to its large size.

Pieter Schelte, which is arguably the world’s biggest ship, left the Daewoo shipyard in South Korea on Wednesday, November 19, and is due to arrive at the Port of Rotterdam in the Netherlands for completion in December. A partnership between Allseas and the Port of Rotterdam, will allow the Pieter Schelte to be taken to the Maasvlakte 2, an extension of the port, where a special pit has been drained to house the vessel for fitting out and completion. In the port of Rotterdam, the 65m (213 ft.) long beams of the

Pieter Schelte at Daewoo shipyard, below and bottom right.

Bottom left, artists rendition with rig topside and legs embarked. **Bottom center**, Pieter Schelte on sea trials.



Pieter Schelte Main Particulars	
Shipyard	DSME
Length, o.a.....	1,253 ft. (382m)
Width.....	407 ft. (124m)
Lift capacity	48,000 tons for topsides using eight sets of horizontal lifting beams, at 6000-tons each, across the slot for removal or installation of topsides. 25,000-tons for jackets, using two tilting lift beams on the stern for lifting and laydown.
Pipelay system.....	A 2000-ton capacity S-Lay pipelay system, able to handle 12m pipe sections under tension using four 500-ton tensioners, with a 170m-long stinger.
Power:	12 thrusters, powered by eight main diesel generators, providing a total installed 95MW power.
Speed.....	14 knots, max
Accommodation	571

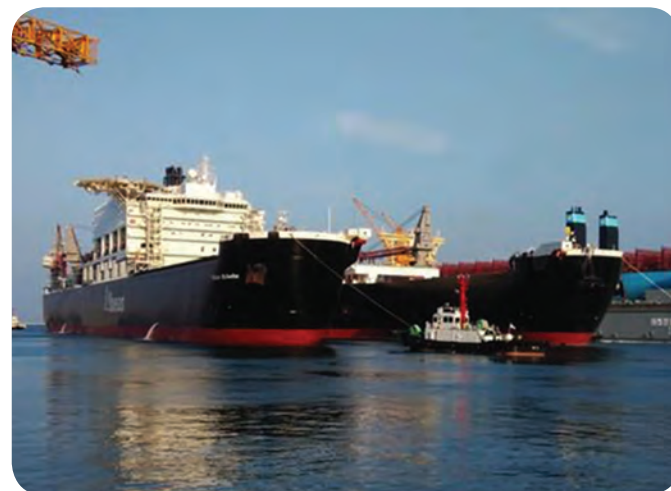
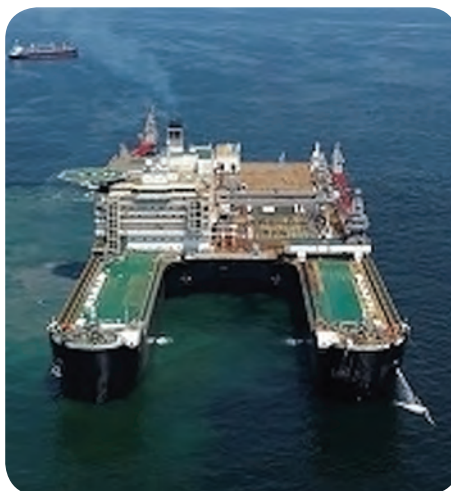

Photos: Allseas

lift system will be installed. The lifting beams are being constructed by Cimolai in Italy and will be transported by ship to the Netherlands.

After these are installed, the ship will undergo trials due to be completed in 2Q 2015.

The lifting trials will use a test frame, with a 5,000-ton capacity water tank, resting on four section piles, to simulate a platform. SPT Offshore and Volker Staal en Funderingen will build the structure in a joint venture. It will be sited in about 100 ft. (33m) water for lifting tests first in a calm sea and then in increasingly rougher weather, deploying the vessel's dynamic positioning compensation system. After the completion and following lifting and stability tests, the Pieter Schelte will undertake its first decommissioning job, which will be the lifting and transporting to port of Talisman's doomed Yme topsides offshore Norway.

"This will be a difficult test because the platform is wobbly, by the nature of the deficiencies in the design of the structure," said Heerema. The Pieter Schelte will then be prepared for the South Stream pipelay project, which comprises an 888km pipeline from Russia, through the Black Sea to Bulgaria. Allseas has the contracts, and depending on timing of the first Brent platform, which is likely to be Brent Delta, it will use the Pieter Schelte, or its pipelay vessel Solitaire for the Black Sea job. Pieter Schelte can lift topsides, which can weigh up to 48,000 tons, while it will also be able to lift jackets weighing up to 25,000 tons. The ship can then transport both the top and bottom sections of the rig simultaneously and take them to a port, shipyard or even install them in a different location. The ship can even raise and lower itself in the water by 82 ft. (25m) in order to cope with the huge weight demands of moving an oil rig. It can reach speeds of 14 knots (16.1 mph or 25.9 km/h) and has space for a crew of 571. When it enters operation it will also be the world's largest pipelaying ship and will be used to construct infrastructure under the sea. Its awesome pipelay capacity of 2,000 tons is double that of the previous record holder, another Allseas ship called Solitaire.

Pieter Schelte will only hold the title of the world's biggest ship for six years as by 2020 Allseas expects to have an even larger ship in operation to install and move bigger oil rigs, probably with an

\$3.1 billion
382 x 124 m
12 x 5.5 MW Thrusters

even greater pipelay capacity. Decommissioning has been infrequent outside of the Gulf of Mexico (where government rules makes it mandatory) and some other shallow-water locations, with the busy offshore Brazil and the North Sea seeing few decommissioning jobs despite a number of platforms being well beyond their design life. There is hope that this will change and the Pieter Schelte could be a financially and operationally sound solution that would help spur operators to remove aging rigs, especially in the North Sea, where 478 rigs may need to be removed before 2045. The vessel has already won a number of contracts for removing three platforms from the Brent field in the North Sea. Along with this, the versatile vessel will be laying 890km (553 miles) of trunkline for the South Stream project. Executives at Allseas are confident its ship's success. The recent *Subsea Vessel Report* from Douglas-Westwood forecasts that \$9.75 billion is to be spent installing pipelines globally between 2015 and 2017, meaning the potential is there for an increased demand from both the decommissioning and deepwater pipelay markets (where the ship's large pipelay capacity will have a greater impact) in coming years. Allseas believes that these facts are positive signs that building the vessel will prove to have been a smart move. "This ship is a challenge for everyone, so it means everybody has to be on their toes. There have been delays, but it is still amazing to get here," said Heerema. Allseas also recognizes that, ultimately, the impact the Pieter Schelte will have on the decommissioning market will depend on operational costs and the ship's efficiency and operational safety. It is known that Shell spent four years studying the ship before awarding the Brent decommissioning contract, and this level of cautiousness can be expected from other players in the oil and gas industry until the Pieter Schelte attains a track record of successful operations.

Allseas executives are so confident that the ship will be successful that they have already made plans for another decommissioning vessel able to lift a staggering 72,000 tons.

Only time will tell if this will become a trend in the decommissioning and pipelay markets and much will depend on the efficiency of the new ship during its first batch of jobs.

“
**...sure hope they have
a Pollution policy from
Great American...**



Look to Great American
for a proven track record of rapid response,
efficient claims handling and a history of
financial strength and stability.

GREAT AMERICAN
INSURANCE GROUP

Ocean Marine Division

Contact Captain Ed Wilmot at 212-510-0135 | ewilmot@gaic.com

Underwritten by Great American Alliance Insurance Company, Great American Assurance Company, Great American Insurance Company, and Great American Insurance Company of New York. Great American Insurance Group, 301 E. Fourth Street, Cincinnati, OH 45202.

CSCL Globe *The world's largest containership*

Hyundai Heavy Industries Co., Ltd. (HHI) has built and delivered the world's largest containership, the first of five 19,000 TEU containerships ordered from China Shipping Container Lines (CSCL) in May 2013.

The first containership in the series was named CSCL Globe, and it measures 1312.3 ft. (400 m) x 192.3 ft. (58.6 m) wide with a 100 ft. (30.5 m) depth. It will be deployed on the Asia-Europe trade loop.

The CSCL Globe will feature a Hyundai-B&W 12S90ME-C9.2 electrically controlled engine with MCR of 69,720 kW at 84 rpm enabling to sail at a service speed of 23 knots at design draft when running at 90% MCR with 15% sea margin burning less fuel of around 195.5 tons per day.

With the installation of the high efficiency engine, the containership will burn 20 percent less fuel per TEU in comparison with the 10,000 TEU container-

ships. The main engine is optimized with low load tuning by exhaust by-pass system for turbocharger for improved fuel consumption at practical operation condition.

A Cylinder Pressure Measuring Indicating system is provided onboard this mammoth ship for main engine, and cylinder pressure and RPM with angle reference are calculated and presented on a ship's computer in engine control room.

It is arranged two islands concept with the separated location of accommodation from engine room for crew comfort and optimum ballast tank arrangement to minimize ballast amount at various loading conditions. Fuel oil tanks are constructed in double

hull structure to protect the fuel oil tanks from external damages. Twenty-seven sets of 3-tier lashing bridges are provided for easy maintenance of 900 FEU reefer containers on deck/hatch cover.

1312 ft. long
19,000 TEU
69,720 kW

CSCL Globe Main Particulars

Shipbuilder	Hyundai Heavy Industries
Vessel's name	CSCL Globe
Type	19,000 TEU Containership
Owner/Operator	China Shipping Container Line
Flag.....	Hong Kong
Classification	GL
IMO number	9695121
Length o.a.....	1312.3 ft. (400 m)
Breadth molded	192.3 ft. (58.6 m)
Depth molded.....	100.1 ft. (30.5 m)
Draft, scantling.....	52.5 ft. (16 m)
Draft, design.....	47.6 ft. (14.5 m)
Gross tonnage	187,541
Deadweight, design.....	155,200MT
Deadweight, scantling	183,800 MT
Speed, service.....	23 knots (90% MCR)
Water ballast	44,400 cu. m.
Daily fuel consumption, Main engine ..	195.5 tons/day
Daily fuel consumption, Auxiliaries	11.2 tons/day
Main engine(s).....	Hyundai-MAN B&W 12S90ME-C9.2
Output	56,800 kW (MCR)



Photos: HHI

Harvey Energy

In 2011 Harvey Gulf International Marine became the first U.S. vessel operator to contract for construction of vessels by LNG. The first of these vessels to be delivered is the Harvey Energy. In addition to being able to operate on cleaner burning natural gas, the Harvey Energy has "ENVIRO+, Green Passport" Certification by the ABS. The requirements for this certification include that the vessel be continuously manned with a certified Environmental Officer, be completely constructed with certified environmentally friendly materials and have advanced alarms for fuel tanks and containment systems. Along with the Enviro+, Green Passport notations, these LNG powered OSV's will be the most environmental friendly OSV's in the North America. When operating on LNG, the Harvey Energy meets the highest environmental emissions standards, and Harvey Energy will exceed the EPA Tier 4 emission requirements that are to take effect on January 1, 2016. Harvey Energy is diesel-electric and powered by Wärtsilä 6L34DF dual-fuel-diesel gensets. Three of them produce a total of 10,100 bhp. They will power two azimuthing stern drives: Wärtsilä

LIPS units producing 3,620 bhp each. The vessel has two bow thrusters: LIPS FT225 M-D units producing 1,717 bhp each. A challenge in designing a boat to run primarily on LNG is onboard LNG storage. Since LNG contains less energy by volume than diesel oil, the LNG tanks have to be significantly larger to give the vessel the same range as with conventional diesel. Harvey Energy has a single 100 ft. long cylindrical LNG tank located along the centerline under the cargo deck just aft of the house. Harvey Gulf selected Gulf Coast Shipyard Group to build the first six of these historic vessels.

LNG pioneer
ABS "ENVIRO+
Green Passport"



SEAWORTHY DROP-IN AIR CONDITIONER

FAST, EASY INSTALLATION - NO PLUMBING OR DUCTWORK

Designed and built for long life and dependable performance in the harsh marine environment.



- Condenser and evaporator coated with ElectroFin® E-coat process for superior corrosion and UV resistance
- Built-in vibration isolation for key components
- Sealed motor and bearings
- Stainless-steel fan motor shaft
- High efficiency, low-power consumption



Compressor stabilization for protection in heavy seas



AER SUPPLY LTD.
2301 NASA PARKWAY SEABROOK, TX 77586 USA
800 767 7606 SALES@AERSUPPLY.COM
AERSUPPLY.COM

 facebook.com/AERsupplyLtd
 [@AERsupplyLtd](https://twitter.com/AERsupplyLtd)

 **Dometic**

Quantum of the Seas *First ship in new class for RCCL*

The "North Star" glass gondola



The bridge

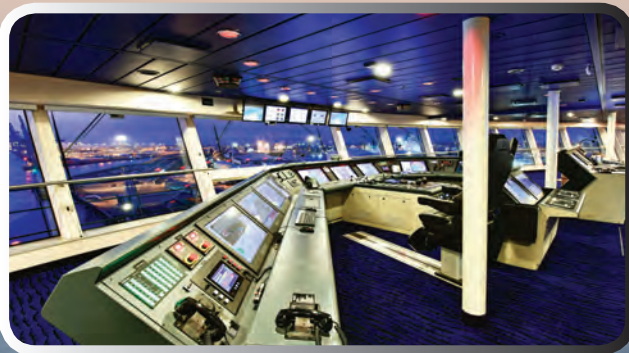

167,800 gt
1141 ft. long
4180 passengers

The "Two70"



Meyer Werft delivered the latest in a long line of cruise ships that grow ever larger and more spectacular in their outfit, final finish and performance. The 167,800-gt cruise ship Quantum of the Seas was built for and delivered to Royal Caribbean Cruises Ltd. (Miami). This is the first ship of the Quantum class. It features highly energy-efficient systems, optimized hydrodynamics, heat recovery, an effective underwater paint coating, a state-of-the-art exhaust gas treatment plant (hybrid scrubber) as well as energy-saving LED lighting systems.

The real technical wonders onboard any modern cruise ship is the size and sophistication of the entertainment options onboard, and Quantum does not disappoint. The theatre is equipped with stage technology which has yet to find its peer ashore. The North Star on deck 17 allows the guests to travel in a glass gondola at a height of 90 m above sea level where they can enjoy a 360-degree panoramic view. On deck 17 aft the RipCord simulates parachuting at sea both for beginners or seasoned parachuters. Surf aficionados may want to look for the perfect wave high above water level on the FlowRider on deck 16. In total 4,180 guests can be accommodated in 2,090 cabins, and are taken care of by a crew of approximately 1,550. On board of the Quantum-class ships the traditional main restaurant has been replaced by dynamic dining, where the guests rotate in five different restaurants. "Seaplex" features the largest indoor activity area at sea that offers entertainment like bumper cars, roller skating, a competition-size basketball court as well as a circus school. **The "Two70" (pictured left)** stretches from deck 4 to 6, a spacious area offering a 270-degree panoramic view of the sea.

Quantum of the Seas Main Particulars	
Dimension.....	167,800 gt
Length overall.....	1141 ft. (347.75 m)
Molded breadth.....	135.8 ft. (41.4 m)
Number of decks.....	18
Draft.....	27.8 ft. (8.5 m)
Engine output	Wärtsilä 2x12V 2x 16V
Total.....	67,200 kW
Propulsion power.....	41,000kW
Speed.....	22 knots
Number of passengers	4,180
Number of passenger cabins	2,090
Number of outside cabins (including suites).....	1717



Semper Fi

10% fuel savings
Hybrid drive
Scania powered

The MV Semper Fi from the Netherlands can be operated with two different engines at the same time: which effectively serves to cut emission of CO2 and save money. This innovative European inland waterway vessel measures 361 x 37.7 x 12.1 ft. (110 x 11.5 x 3.7 m).

In cooperation with MARIN, the Netherlands Maritime Research Institute in Wageningen, the Dutch shipping company Carpe Diem Shipping developed the novel concept of Semper Fi, which reportedly is the first inland vessel that can simultaneously be propelled by a diesel engine and an electric motor – a unique combination, and one that has confirmed a 10% savings in energy consumption.

The hybrid drive is not the only sensation of the SEMPER FI project. Contra-rotating rudder propellers of VETH Propulsion type VZ-900A-CR-VHD, optimize the propulsion system. Propellers turning in opposite directions offer the decisive advantage in that they are not only made for improved maneuverability but also for extremely quiet operation – an important criteria for inland

shipping. The streamlined tunnel and the variability of the propeller, which can be controlled in all directions, adds to the system's efficiency and versatility. Thanks to an integrated exhaust post-treatment system with 4 SCRT which include catalytic converters and soot filters, the SEMPER FI makes an additional contribution towards minimizing noxious emissions in inland shipping. In this process, the combustion gases are chemically cleaned using the so-called AdBlue method. A urea-based liquid is injected to bind the exhaust particulates and reduce the levels of nitrogen oxides. The AdBlue exhaust post-treatment system was supplied to the Semper Fi project by Veth Propulsion. The drive consist of: two Scania engines DI16 (512 kW / 1800 rpm), two E-engines (330 kW / 1800 rpm), two generating sets, Scania DI16 (634 kVA / 1800 rpm), two frequency converters for propulsion, one frequency converter for bow thruster, one static converter to supply power to the board net, all supplied by VETH Propulsion.

MV Semper Fi Main Particulars

Main drive.....	Veth Propulsion B.V., NL
Hull maker	Shipyards Orsova, Romania
Yard	A.A.Vink, Sliedrecht, NL
Wheelhouse.....	EBR Marine Construction, NL
Interieur	Willemssen interieurbouw&scheepsbetimmering b.v.
Pumps.....	All Pumps Holland B.V., NL
Heat exchanger	Blokland Non-Ferro B.V., NL
Electrical installation/batteries.....	EMS, Electric Marine Support Binnenvaart B.V., NL
Class notation.....	DNV GL
CFD simulation	MARIN, NL
Length x Width x Depth	361 x 37.7 x 12.1 ft. (110 x 11.5 x 3.7 m)
Main drive.....	2 x hybrid drives: 2 x Scania DI 16 (512 kW @ 1.800 rpm)
.....	2 x electric motors (330 kW @1.800 rpm)
Generating sets.....	2 x Scania DI 16 (634 kVA @ 1.800 rpm)
Propeller.....	2 x VETH contra rotating VZ-900A-CR-VHD
Load capacity	255 TEU, + 50 reefer

We put afloat
your marine projects

SENAV

ASTILLEROS NAVALES

Is the new one shipyard

to boats repairs and shipbuilding in to the coast of Pacific Mexican

Main Capacities:

- Cradle Lift : 3,000 MT
- Maximum keel length support : 64.0 M
- Maximum beam inside the laterals supports : 17.0 M
- Maximum length over all of the boat : 110.0 M
- Maximum draft over keel block with 6" margin : 6.2 M
- Transfer system at five dock repair places to 3000 mt and 110 m length

Working Facilities:

- Sandblasting and painting
- Maintenance of valves and piping
- Maintenance of propulsion, propeller, shafts and replacement of the mechanical seals
- Structural repair of steel and aluminum

Engineering and Design:

- Conversion, lengthening and upgrading of ships
- Area to new constructions with over 34,000 m2
- Tuna boat specialist

contact us
tel.+52 (669) 180.2000
comercializacion@senav.com.mx
Mazatlán, Sinaloa, México

senav.com.mx

Ceona Amazon *Next-generation Deepwater Construction Vessels*

Dramatic changes to the global oil and gas landscape over the last decade have led the industry to encounter increasingly challenging and remote environments including emerging yet largely unexplored new provinces and more complex deepwater territories.

But true to its industrious and adventurous spirit, the sector is turning these challenges into opportunities and under-

pinning this shift to new frontiers is adding significant tangible value to the way in which hydrocarbons are recovered.

It is not only enabling the industry to unlock reserves and ensure security of supplies but increasingly improving efficiency and reducing costs by applying more effective methods that both mitigate risk and optimise production. The recent drop of oil barrel value has made cost reduction crucial.

With a large product carrying capacity and the ability to tackle multiple pipelay worksopes and perform heavy construction in one trip, The Ceona Amazon is a multi-function construction vessel designed to support the energy industry in the most logistically challenging deepwater field developments at optimised costs.

Built at Crist yard in Poland and outfitted at Lloyd Werft yard in Bremerhaven,

Germany, The Amazon is Ceona's flagship vessel.

Conceived in house and fully owned by the company, The Amazon represents the next generation of the company's fleet. Ceona is a subsea umbilicals, risers and flowlines (SURF) contractor with heavy subsea construction capabilities and a growing geographical footprint, particularly in West Africa, the Gulf of Mexico and Brazil.



Tandem Mast Cranes
equals efficiency
in operation.

Ceona Amazon Main Particulars

Length, o.a.....	655 ft.
Breadth.....	106 ft.
Design draft.....	25 ft.
Gross tonnage.....	33,000 mt
Speed, transit.....	14 knots
Speed, service.....	12.4 knots
Dynamic positioning.....	DP2
Thrusters.....	7
Generator power.....	37,500 hp
Main moon pool.....	26ft x 44ft
ROV System.....	Schilling UHD
Classification.....	GL
Builder.....	Crist Yard, Poland
.....	Lloyd Werft, Bremerhaven
Flag.....	Gibraltar
Gross tonnage.....	33,000 mt
Net tonnage.....	9,900 mt
DPS.....	Kongsberg K-Pos DP21
Accommodation.....	16 x single cabins
.....	200 persons: 92 x double cabins
Fuel oil.....	123,000 cu. ft.
Fresh water.....	29,000 cu. ft.
Ballast water.....	443,000 cu. ft.
Heeling water.....	124,000 cu. ft.
Power Plant.....	4 x MAN 8L32/
.....	44CR @ 6,000hp each
.....	.2x MAN 9L32 /44CR @ 6,800hp each
Stern Thruster Group.....	3 x Azimuth,
.....	Steerprop @ 4,700hp
Bow Thruster Group.....	3 x Retractable
.....	Azimuth, Brunvoll @ 3,800hp
.....	1 x Tunnel, Brunvoll @ 2,400hp
NAVCOM.....	SAM Electronics
.....	NACOS Platinum

The Ceona Amazon includes a combination of capacities, such as spool base independent pipelay, heavy lift (two 400t cranes working in tandem) and subsea construction (including floaters installation) with the vessel designed to be weather resilient and technically versatile.

At 199-m in length, the ship is able to offer one-stop-shop offshore trips for clients' projects. It boasts a huge product carrying capacity (5,000t of flexible or 8,500t of rigid pipe stored on and below her 4,600 sw. m. deck), twin 400-ton heave compensated (AHC) mast head cranes capable of working in tandem lifting mode, innovative on-vessel pipeline fabrication capabilities (welding, non-destructive testing and FJC) and superior operability (drill ship design hull with mid-ship moonpool) – each feature positioning

The ship is due to be fully operational early in 2015 following the final installation of a 570-ton pipelay tower and the cranes at Huisman yard in Schiedam, the Netherlands, where the Ceona Amazon will become fully fledged as a uniquely versatile subsea construction vessel.

The pipelay system consists of a tower with a top tension of 570-ton. It can lay rigid, flexible pipelines and umbilicals, risers and install large subsea structures using one or both of its cranes in tandem lift mode.

Ceona Amazon has an innovative configured G-lay pipelay system (under patent application) which combines components of well-known tried and tested pipelay systems (J-S and Reel-lay).

The welding line is traditional S-lay, however once welded, the pipe is deflected around a stern wheel and installed through a conventional pipelay tower with two tensioners and a total top tension of 570t in deep water.

There is also space left on the large back deck to hold a vast complement of project specific equipment such as suction anchors, this is complemented with sizeable under-deck storage. The vessel's huge capacity avoids the requirement to call for the support of an offshore supply barge as well as allowing for faster pipelay capabilities.

The combination of the mast cranes capable of operating in tandem supports the lowering of large structures to water depths of 3000m to install FPSOs, Semis or TLPs and alleviates the need for a second vessel, as is common for such operations.

In addition, due to the tandem crane arrangements, very long and complex spools are easily managed. The AHC

cranes will be accompanied by a single 30t heave compensated knuckle boom crane.

Based on a drill ship hull, the mid-ship moonpool allows operations to continue in tougher sea and wind conditions than

her peers. The pipelay tower is placed as close to the transverse axes of the vessel as possible to minimise the effect of vessel motions on the pipe installation stresses. At 8m by 13.5m the moonpool is large enough for the biggest PLETs.

Through her versatility, heavy lift capabilities and large storage capacity, the Ceona Amazon is a unique vessel that offers considerable added value to the energy industry as it enters increasingly challenging deepwater territories.



ENGINEERED FOR RELIABILITY

PROTECT, MONITOR, AND CONTROL CRITICAL POWER SYSTEMS

As a leader in power system protection, control, and automation, SEL sets the standard for mitigating blackouts on offshore platforms and marine vessels. Our solutions are deployed worldwide in operations that demand continuous power, and we support those systems with highly experienced, local engineers.

- Mitigate arc-flash hazards to protect personnel and equipment.
- Protect and monitor generators, feeders, buses, and transformers.
- Diagnose power quality problems.
- Combat cyber threats with defense-in-depth cybersecurity.
- Depend on SEL Engineering Services for complete power management solutions.

To learn how we can support your power system needs, visit www.selinc.com/12mr.



SEL modernsolutions
power systems conference

June 3-5, 2015 · Chicago, IL · www.selinc.com/mspsc

R/V Neil Armstrong

A multi-faceted explorer of the seas

The Ocean Class Auxiliary General Oceanographic Research (AGOR) vessel hull number 27 started its official life as the R/V Neil Armstrong, the first research vessel named after a space explorer. The ship was designed by Guido Perla and Associates and built at Dakota Creek Industries (DCI). R/V Neil Armstrong will replace the R/V Knorr, in service since 1968, one year before Armstrong's walk on the moon. The R/V Knorr, AGOR-15, is retiring after logging over one million miles in service to the Navy and WHOI. Initial vessel construction for the two-ship, \$145-million-dollar project is funded by NAVSEA who will retain ownership of the vessel. Scientists from WHOI and around the world will be the primary users conducting year-round research in the North Atlantic and Arctic Oceans. WHOI will contribute \$350,000 a year for maintenance and operation of the vessel. Research will include mapping of the seafloor, launching of buoys, ROVs and other equipment, studying how currents affect acoustic signatures, microbial content of the northern waters, discovering how climate change and sea level rise are impacting the North Atlantic, and how the ocean in turn impacts climate changes. The focus will be on the entire eco-system. The physics, biology and chemistry of the high latitude oceans will fall within the Neil Arm-

strong's mission area.

The ships are 238 ft. in length overall, have a sustained speed of 12 knots and travel over 11,000 nautical miles without refueling. In addition, they have the most modern scientific laboratory facilities and workshops afloat, high-tech computer and oceanographic equipment, and hotel facilities to support 24 scientists and a crew of 20. They are built to ABS Under 90 Meter rules, and will be certified as A1, Circle E, AMS, ACCU, NIBS, Ice Class D0, and UWILD. The design is also compliant with 46CFR Subchapter U (Oceanographic Vessels).

Working deck space is a premium in oceanographic work. The AGOR vessels have 2,557 sq. ft. of clear deck space with 1,873 sq ft of that space on the open aft deck. Design specifications included being fully operational in Sea State 4 and able to handle dynamic positioning relative to a fixed position in Sea State 5 with a 35-knot wind and 2-knot current.

Additionally, the ship had to be as operationally quiet as possible. A great deal of ocean research involves listening. Excessive ship noise would negate that effort. GPA's unique hull design meets the Bubble Sweepdown performance requirement of the original specifications by diverting bubbles away from the sensitive sonar area. Model tank tests performed in Poland confirmed the Phase 1 design efforts met the Navy's exacting

standards. Completing the noise dampening goal, designers chose systems, defined equipment locations, and designed special installation methods with acoustics as a priority.

Siemens installed its new Blue system, an advanced, multi-drive, low-voltage system manages the speed of various AC propulsion motors controlling the propellers, stern thruster and bow thruster. The system provides enhanced reliability with multiple failsafe features, lower maintenance costs, increased efficiency, and increased operational ease for the crew. Reduced fuel consumption results in lower greenhouse gas emissions. Siemens is also supplying the majority of the electrical switchgear, the ACCU automation, and condition-based monitoring system. The vessel uses four vibration-isolated Cummins QSK38-DM main generators providing a maximum of 3952 kW integrated electric power for all functions of the ship, including propulsion. The integrated diesel-electric plant allows for multiple generator configurations, ensuring the diesel engines operate at peak efficiency at all times.

A unique feature of the electric propulsion will be a "combinator" style control function integrating management of motor speed and propeller pitch on the Hundested-supplied Controllable Pitch Propellers. Although fairly common in controllable pitch systems with direct

drive diesels, use of the combinator control is unusual in variable-speed electric drive systems. The combinator increases operational flexibility by allowing the operator to set the propeller at its most efficient setting across a range of operations including heavy towing and cruising. Design specifications were stringent for deck cranes and winches. They needed the capacity to load equipment weighing more than 20,000 pounds including the deployment of ROVs, buoys and other heavy equipment. The stern frame required a minimum of 12-foot inboard and outboard reach. As designed, the frame provides 15 feet of clearance above the deck and 27 feet of clear space between the block attachment points, all while maintaining a Dynamic Safe Working Load of 30,000 pounds through the full range of motion. Allied Marine supplied the stern frame along with the portable TK4-30 portable crane and the TK 70-70 aft-deck Main Crane. It also supplied the Motion Compensated CTD Handling System and the Starboard Side Handling Device, both of which extend to the waterline for improved safety and load control.

Markey Machinery supplied two electric-motor driven CAST-6-125 Hydrographic Winches, and the DETW-9-11 Traction Winch, both with AC Variable Frequency Drives System and electric motors for precise control.

Two ships, \$145m
GPA designed
Diesel Electric propulsion

(Photo courtesy of Gary McGrath, WHOI)



AGOR 27 - R/V Neil Armstrong
Yard Dakota Creek Industries (DCI),
Designer.... Guido Perla and Associates
Owner.....NAVSEA
Operator.....WHOI
Class ABS
Main engines..... Cummins
Propulsion SystemSiemens Marine
Cranes..... Allied Marine
Winches Markey Machinery
Sonar..... Kongsberg Maritime
Survey Sonardyne
Design... Guido Perla & Associates, Inc.
Diesel generatos 4 x Cummins
Propulsion Drive Siemens
Winches Markey
Survey Systems Kongsberg
A-Frame, Crane..... Allied Systems
Rescue Boat Davit..... Schat Harding
Stern Thruster..... Schottel, 1x 620kW
Bow Thrusters..... White Gill, 1x 686kW
Emergency Generator . MTU, 1x 210kW

Linda Oldendorff

First of Six
208,000 dwt bulk carrier
HHI built



Linda Oldendorff Main Particulars

Shipbuilder ..	Hyundai Heavy Industries
Type	208,000 dwt Bulk Carrier
Owner/Operator	Oldendorff
Tonnage	172,970 DWT
Flag.....	Liberia
Classification	NK
Engines	HYUNDAI-MAN B&W 6G70ME-C9.2
Propulsion..	MCR: 16,200 kW x 73 rpm
Delivery due.....	September 30, 2014
IMO number.....	9691929
Length o.a.....	300 m
Breadth molded	50 m
Depth molded.....	25 m
Draft, scantling.....	18.5 m
Draft, design.....	16 m
Gross tonnage	109,000
Deadweight, design.....	172,970 MT
Deadweight, scantling	207,570 MT
Speed, service.....	14 knots (90% MCR)
Bunkers, Heavy oil.....	5,300 cu. m.
Bunkers, Diesel oil	400 cu. m.
Water ballast	66,600 cu. m.
Consumption, Main engine	46.4 tons/day
Consumption, Auxiliaries ..	3.8 tons/day
Classification	NK
Main engine.....	Hyundai-MAN B&W 6G70ME-C9.2
Officers/Crew.....	11/14
Bridge control system	Kongsberg
Fire detection	Autronica
Radar	Furuno

The 208,000 DWT Bulk Carrier Linda Oldendorff built at Hyundai Heavy Industries Co., Ltd. (HHI) was delivered to Oldendorff in Germany on September 30, 2014. It is the first in a series of six.

The vessel has flush deck with forecastle, bulbous bow, transom stern, single rudder (full-spade) and single screw propeller directly driven by a slow speed diesel engine. It measures 300 x 50 x 25m, with a 16-m draft.

The vessel has nine cargo holds and was constructed as single hull with hopper sided double bottom and topside wing. No.6 cargo hold may be used as water ballast tank for bal-

last voyage under heavy weather. The vessel is powered by a Hyundai-B&W 6G70ME-C9.2 main engine with an NCR output of 12,300kW at 66.6 rpm/min, enabling her to sail at a service speed of 14 knots.

The main engine is optimized with low load tuning by exhaust gas by-pass system for turbocharger for improvement of fuel consumption at practical operation condition.

Daily fuel oil consumption at the normal continuous rating of main engine is 46.4 metric tons based on marine diesel oil of 42,700 kJ/kg in lower calorific value at shop test. MEWIS duct as an energy saving device is installed at the stern.

OUR NEW HOUSTON HOME!

TTS Marine

Services
Deck Equipment
Cargo Access
Offshore
Heavy Lift

service@tts-se.us
www.ttsgroup.com
+1 281 227 5999

FAST. SAFE. RELIABLE.
Vessel & Rig Repair

Serving the Galveston, Houston and Texas Gulf Coast area, Malin International Ship Repair & Drydock is a full service topside repair facility ready to handle your scheduled or emergency repairs.

- All types of Rigs, Subsea Construction and Offshore specialty vessels, Tankers and Cargo Ships
- GOM Offshore Repair/Riding / Travelling Crews • Full service machine shop / 7000 SF Fabrication Shop
- Over 1400 feet of Wet Berth space at the pier

info@malinshiprepair.com
www.malinshiprepair.com
A Lorton Marine Company

Top Coral Do Atlantico *A "Mega" Pipelayer*

TOP Coral do Atlantico is the first of two, characterized by a high pipeline tension capacity of 550 tons and a storage capacity of 4,000 tons, designed to install umbilical and flexible flowlines and risers to connect subsea wells to floating production units in water up to more than 2,500m deep off the coast of Brazil, including the pre-salt area. A long-term charter agreement has already been made with Petrobras.

To support subsea installation work, a 250 ton-capacity deck crane was equipped with AHC (active heave compensation). AHC function recognizes the vessel's motion and provides stable subsea lifts and underwater load handling in water up to 3000m in depth so that the underwater installation work is less affected by wave and weather conditions. In terms of stability during offshore work, in order to meet the need for efficient flexible pipe laying operations, an anti-heeling & anti-rolling system was also installed. Such a system will make it possible to perform elaborate stability

control to cope with various operational situations. The vessel is a DP2-classed vessel and can be dynamically positioned using seven thrusters, which are composed of three kinds: three azimuth propulsion thrusters, two retractable thrusters, and two tunnel thrusters.

Top Coral Do Atlantico Main Particulars	
Type.....	Pipe layer
Shipyard.....	DSME Okpo Shipyard
Owner.....	Technip Odebrecht
.....	PLSV CV (Brazil)
Length, o.a.....	135m
Beam.....	30m
Depth.....	10m
Tonnage.....	13,928
GRT.....	17602
Flag.....	Bahama
Classification.....	DNV-GL
Engines..	Medium Speed Diesel Engine
.....	6 sets: 4x3,800kW, 2x3,300kW
Propulsion.....	Azimuth, FPP with
.....	nozzle 3 sets: 3,000kW
Delivery.....	July 2014



CSAV Tyndall *Biggest Black Sea area-built Containership*

CSAV Tyndall is an 8600 TEU containership built by Daewoo Mangalia Heavy Industries (DMHI) and is part of a series of four containerships delivered to Zodiac Maritime Agencies Ltd. (UK) between 2013 and beginning of 2014. These projects are the biggest containerships ever built in the Black Sea and Mediterranean Sea area.

The vessel measures 299.9 x 48.4 x 14.5 m and has a maximum speed more than 25 knots powered by a MAN B&W licensed main engine rated at 64,485

HP. The ship was built under the supervision of Lloyd's Register and registered in Monrovia, Liberia. Compañía Sud Americana de Vapores (CSAV) is the charterer of this series for long-term.

The ship series features a number of state-of-the-art technologies designed to reduce emissions and fuel costs.

Chief among them is a device used to enhance the flow into the propeller in order to increase propulsion efficiency and reduce energy loss, the Pre-Swirl Stator (PSS).

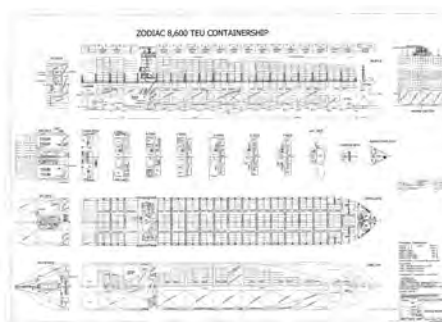

CSAV Tyndall Main Particulars	
Shipbuilder	Daewoo-Mangalia Heavy Industries (Romania)
Ship owner.....	Zodiac Maritime
IMO No.	9627928
Length.....	299.9m
Breadth.....	48.4 m
Depth.....	24.8m
Draft.....	14.5m (scantling)
Draft.....	12.5 (design)
GT.....	96,628
Speed, service.....	21.95 knots
Classification.....	Lloyd's Register
Engine	MAN B&W 9S90ME-C8.2-TII

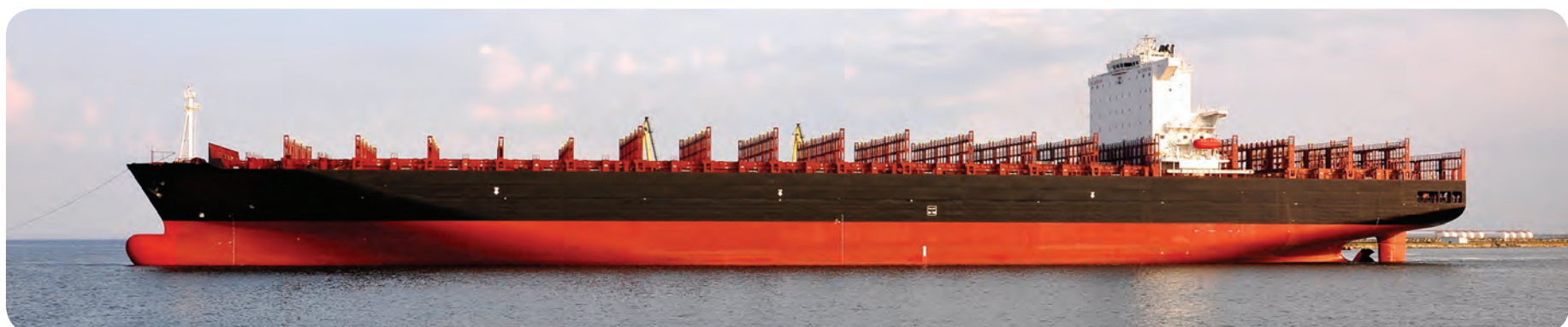



Norwegian ferry operator Norled AS received the battery-driven car ferry ZeroCat 120, an aluminum catamaran which is light-weight with slender twin hulls. Its electric power train was designed by Norway's Fjellstrand shipyard with battery technology from Germany's Siemens. The ZeroCat 120 does not discharge greenhouse gases, CO₂, methane or nitrogen oxides to the environment. In addition to the environmental benefits, the ferry's operational and maintenance costs will be lower than those of a conventional ferry. Norled will operate the world's first battery-driven ferry on the Lavik-Oppedal route in south-west Norway. The 265 ft. (80.8 m)-long vessel will be able to carry 120 cars and 350 passengers across the Sognefjord. It will run 34 times each day, with a crossing time of 20 minutes. Time at port is 10 minutes, during which the 1-MWh lithium-polymer battery pack on board will be fully charged. This amount of electric power delivered in such a short time is far beyond the capacity of the electrical grid serving the villages of Lavik and Oppedal. The solution is to install battery buffers at both ports that can be continuously charged from the grid with 250 kW, then rapidly provide a quick dump to the ferry's batteries.

ZeroCat 120 Main Particulars

Owner..... Norled AS, Norway
 Yard Fjellstrand AS
 Type Ferry
 Length 265 ft. (80.8m)
 Width 68 ft. (20.8 m)
 Draft 19.7 ft. (6 m)
 Main drive..... 2 x electric motors
 Output 2 x 450 kW
 Propeller..... RollsRoyce AZP 085
 Speed..... 14 knots, max.
 Class DNV GL
 Azimuthing thrusters..... RollsRoyce
 Electric propulsion Siemens
 Battery life time 10 years
 Service speed..... 10 knots
 Car deck.... 120 car units; 8 truck units
 Passenger capacity 350

Harvest Frost *Ship Floats on Bubbles*

The first of three bulk carriers was delivered to Archer Daniels Midland Company (ADM), unique in that the ship features a host of innovative technologies, including the Mitsubishi Air Lubrication System (MALS), which reportedly helps the ship to achieve a 27% reduction in CO₂ emissions as compared to conventional bulk carriers of the same capacity. Developed by Mitsubishi Heavy Industries, Ltd. (MHI) and built at Oshima Shipbuilding Co., Ltd. of Nagasaki, an MHI licensing partner, the centerpiece of the new ship is the incorporation of MHI's proprietary Mitsubishi Air Lubrication System (MALS), which is designed to reduce frictional resistance between the vessel hull and seawater using air bubbles produced at the vessel bottom. The new ship series was ordered by

ADM in 2011, and delivery of the three vessels is scheduled for completion by mid-2015. The carriers are 777.5 ft. (237 m) in length, 131.2 ft. (40m) wide with a 41 ft. (12.5m) design draft and a deadweight tonnage (DWT) of approximately 95,000 tons. In addition to the MALS system, the new vessel features a new bow shape designed to reduce wave-making resistance.



Mike Foster
Vice President, General Manager
mfoster@senescmarine.com
 (401) 226-1042 cell

Kyryll Karayev P.E.
Repair Yard Manager, Dry Dock Master
kkarayev@senescmarine.com
 (401) 639-9325 cell

When impeccable quality from the keel to the pilot house is an owner's goal to assure lifelong structural and mechanical integrity, reliability of operation and pride of ownership Senesco Marine will construct the marine vessels your company will be proud to own and operate.

Craftsmen Not Just Constructors

Gas Star

84,000 CBM LPG Carrier

Gas Star is the first of two 84,000 CBM LPG Carrier built by Hyundai Heavy Industries for KSS. The vessel measures 225 x 36.6 m, with a depth of 22.2 m and a design draft of 11.6 m.

The ship is powered by a HYUNDAI-MAN B&W 6S60MC-C8.2 main engine with a NCR output of 11,340 kW at 89.5 rpm, enabling it to sail at a service speed of 16.8 knots with 15% sea margin. Electrical supply is derived from three generators of 1,140 kW, plus an emergency unit of 150 kW.

It has a cargo space divided into four

cargo holds. Each hold accommodates a free-standing and saddle supported prismatic cargo tank, designed for a maximum vapor pressure of 0.275 bars g and a lowest operating temperature -50 degrees C. Cargo tanks are insulated with 120 mm thick sprayed polyurethane foam with 1-3 mm polymeric coating. Fuel oil tanks are constructed in double hull structure to protect the fuel oil tanks from external damages.

It is designed for simultaneous loading, transport and discharging of two grades of cargo, both of which may be refrigerated, and it is capable of containing

and handling commercial butane (ISO and normal), pure propane, commercial propane (max 5.0 mole % ethane in the liquid phase), mixture of propane and butane in any proportion and propylene. It is also capable of carrying other products, provided that their aggressiveness, pressure, temperature and specific gravity are within the limits of the design.

A reliquefaction plant of the carrier can simultaneously handle two grades of refrigerated cargo, and major equipments such as four oil free, three cylinders three stage cargo compressors and motors are located on main deck in enclosed

deck house. One cargo heater (combined with vapourizer) and one inert gas generator are provided. Three 1,140 kW diesel generators, one auxiliary boiler (3,000 kg/h), one exhaust gas economizer (1,500 kg/h) for the main engine is provided. Cargo unloading is conducted by a pair of deepwell pumps per each cargo tank, each with a capacity of 600 cu. m./hr., allowing for discharge of a full cargo in about 19 hours. Loading a full cargo, at maximum rate of 4,800 cu. m./hr. from fully refrigerated atmospheric storage is accomplished in about 19 hours based on vapor return to shore.



M/V Harvest Leader *ECO Class PCTC*

Harvest Leader is an ECO CLASS 7700 units PCTC, built at Hyundai Mipo Dock (HMD) and delivered in October 2014 with a CLEAN class notation. The efficient Post Panamax design was achieved via close collaboration of the owner, the builder and class, in this case DNV GL. The most significant improvement is in the field of energy efficiency in terms of fuel consumption per unit carried, which the owner claims is presently the lowest in the PCTC market. It stands at 5.95 kg MDO per day per unit carried at 20 knots, a reduction of over 30% compared with previous designs. This was achieved in two ways: widening the ship provided a better stability which enabled raising the cargo hold by one additional deck. Both raised the number of units carried; and a new green electronic MAN 7G60 MEC main engine combined with a large propeller diameter at slow RPM enhanced the propulsion efficiency.

Additional contributors to the economics of the ship are: Optimized hull lines; a Promas system; High load tuning of the main engine; High efficiency turbo chargers; Special anti-fouling paint reducing drag; Fuel oil shifter to diminish dependence on oil fired boiler for steam production; Frequency controllers saving electrical energy on steering gear motors, sea water cooling pumps, air conditioning units, and engine room ventilation fans; as well as LED lights for reducing electrical consumption and enhancing luminosity.

Additional "Green Design" details are:

- The ship's flare angles (Kanerwa formula) are designed to minimize slamming impact and afford good sea keeping together with a slanted bow shape, both reduce wind and weather resistance.
- Strict environmental regulation is enforced by installing low energy consumption Alfa Laval Pure Ballast mark 3.0. Moreover, the ship is prepared in space and design for scrubber installation to meet future SOX regulation.
- An oily water separator is installed with down to 5ppm, and it is equipped with fat separators and plastic shredder to reduce the volume of waste. All fuel and oil tanks, even the smallest ones, are kept away from ship's shell to avoid the slightest risk for pollution due damage.

Noise reduction levels are in accordance with latest IMO rules. All electrical cables on board are halogen free which are smokeless in case of fire, avoiding toxic gases. The CO2 fire extinguishing lines are connected to sea water as an option for smothering. Twin ECDIS equipped with the latest collision avoidance feature for the OOW. An ECDIS unit is installed in the engine control room for the engine team to be aware of where and what is expected during ship's maneuvers.

The ship is fully automated, with about 1,500 I/O monitoring and control points, including ship's stability, automatic anti heeling, trip optimization tool, lighting and fans all controlled from a keyboards.



Bolting solutions



With Superbolt tensioners you no longer need high powered tooling. Any size tensioner can be installed or removed with hand tools.

The simple solution to bolting problems!

ADVANTAGES:

- Increases worker safety
- Accurate & reusable
- Reduces downtime



*Superbolt, Inc. is part of the Nord-Lock Group.

Download brochure & case studies:
www.superbolt.com

Lindenau's Concept: Waste Recycling Ships

By Eric Haun

Millions of tons of waste reach the oceans each year, causing the sea to become the planet's largest garbage depot, as inadequate or nonexistent waste management systems – particularly in coastal and island communities – enable massive patches of marine debris to form around the globe. In an effort to end this process ashore and in the seas, German entrepreneur and shipbuilder Dirk Lindenau, backed by a group of German specialists and funded by the German federal foundation of environment DBU, has produced a Waste-Recycling-Ship (WRS) concept

that aims to provide an efficient, economical and sustainable waste management solution for islands as well as large coastal and river cities. The team intends to implement German waste recycling technologies aboard ships converted at a Kiel, Germany, shipyard to collect, process and recycle waste on board in a safe, economical and environmentally friendly manner. According to Lindenau, it is often not possible to install modern waste treatment plants on islands and coast areas for a number of economical, geographical or logistical reasons. A feasibility study on the Maldives Islands promoted by DBU

found that the goals of the ship concept – regulatory management and collection of wastes, the separation of the wastes on board, and utilization of the materials as resources – are particularly effective for these states, enabling waste management to be performed when not otherwise possible. The ship-bound solution aims to systematically collect waste and separate it on board during loading, travel and unloading. Waste can then be handled on board through mechanical and biological treatment technology to produce secondary raw materials and energy through three main fraction groups, further con-

tributing to the concept's proposed sustainability. The **organic fraction** group is converted by fermentation process into compost and biogas, which is then converted in a gas-operated power heat coupling plant to electric power and heat. The **light fraction** group, converted similarly in a power heat coupling plant to electric power and heat, can be used to produce clean water, compost and electricity from waste resources. Lastly, the **heavy fraction** group will load metal, electronic components and materials, etc. into containers to be sold for recycling.

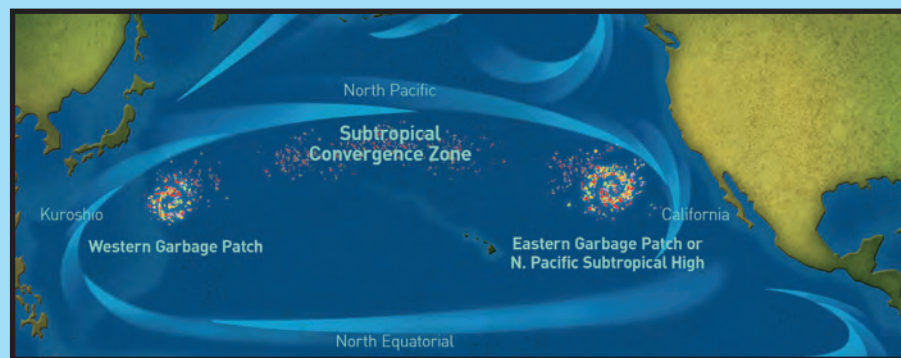

Garbage patches in the Pacific Ocean.
(Image: NOAA)

Lindenau WRS Concept:
The converted waste recycling ship on the round trip route to collect and process waste.

Lindenau Project:
The Waste-Recycling-Ship-Concept for the Maldives.

The LME Waste-Recycling-Ship-Concept

Module 1: Waste-Recycling-Ship

Waste Recycling Ship

Length over all	138,00 m	Endurance	10.000 sm
Breadth	25,00 m	Recycling capacity	140.000 t/a
Draught	5,50 m	Class sign	"Bauer Engel"

Dipl.-Ing. Dirk Lindenau
 Lindenau Maritime Engineering & Projecting
 Team of Waste Recycling Ship:
 Prof. Klaus Fricke, Dipl.-Ing. Burkart Schulte,
 Prof. Dipl.-Ing. Andreas Meyer-Bohe

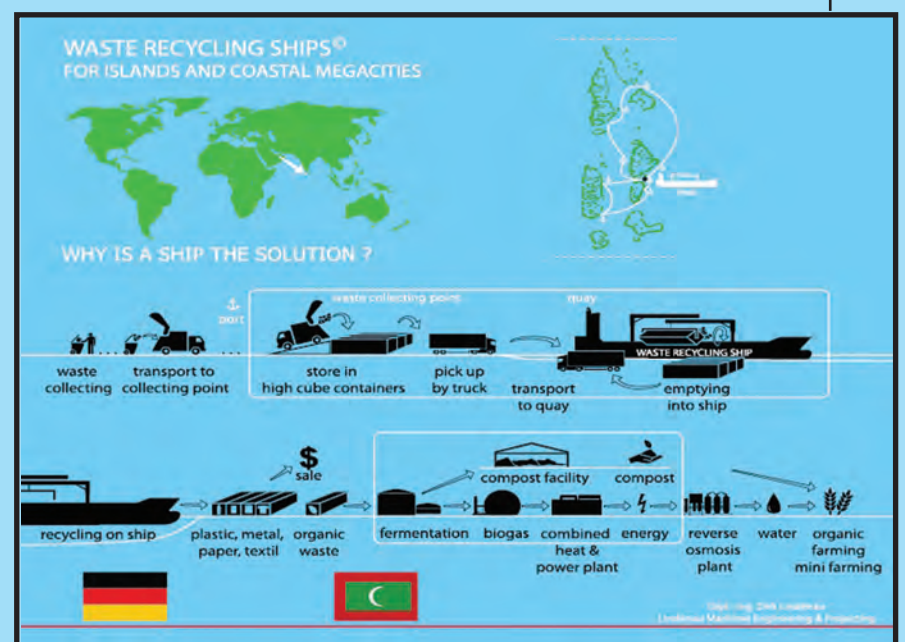



Siem Moxie

The ISV Siem Moxie, an Ulstein SX 163 design not only has been deemed a “Great Ship” in our pages, it has also been awarded the “Offshore Renewables Awards 2014” and the “Innovation Awards” by an international panel. The Siem Moxie measures 242 x 55.7 ft. (74 x 17 m). It is the very first X-Bow support vessel which features two sets of Voith Schneider Propellers. Both the Voith Schneider Propellers are also used for its active roll stabilization system and dynamic positioning (DP-class 2). Its design drew on a wealth of experience within the offshore business. Its specific role will be to support work crews to the platforms and foundations in order to prepare for the submarine cable pull-in and terminations. In addition the vessel can also be used to support the erection and maintenance of the wind turbines, which are typically installed once the installation of submarine cables has been completed. The Siem Moxie’s low fuel consumption makes it particularly environmentally friendly. The vessel’s key features are a 3D motion-compensated knuckle boom crane and an active

motion compensated personnel transfer gangway, permitting the safe transfer of work crews. Thanks to the ship’s active roll stabilization capabilities, offshore works can continue even in challenging sea and wind conditions. “We chose the Siem Moxie because it will make our installation operations extremely safe and efficient,” Sven Utermöhlen explains. “In addition it will help make the construction of offshore wind farms more cost-effective, thereby helping this technology move closer to market maturity.” The SIEM MOXIE is deployed on E.ON’s Amrumbank West offshore wind farm project by Siem Offshore Contractors for the installation of the inner array grid submarine cable system. It is the vessel’s first area of operation. Amrumbank West is an offshore wind farm located north of Helgoland in the North Sea, which E.ON has been building since January 2014. Amrumbank West will extend over 32 square kilometres. Its 80 technologically advanced 3.6 megawatt wind turbines will give it a total capacity of 288 megawatts, enough to power up to 300,000 households.

Höegh Jacksonville



Höegh Jacksonville was delivered by Daewoo-Mangalia Heavy Industries S.A. (DMHI), the first from a series of two 6,500 units Pure Car Truck Carrier (PCTC). This vessel is owned by Ocean Yield from Norway while the charterer is Höegh Autoliners AS, a leading global provider of RoRo vehicle transportation services, based also in Norway.

The vessel, the biggest of her type ever built into the Black Sea and the Mediterranean Sea area, measures 655.8 x 105.8 x 32.2 ft. (199.9 x 32.26 x 10 m), a maximum speed of more than 16 knots, powered by a MAN B&W licensed main engine rated at 8,330 kW. The ship was built under the supervision of DNV and registered in a port of NIS (Norway International Ship Register). The vessel presented challenges in terms of welding thin plates and designing for maximum vehicle loading capacity in a small space. In addition to the vessel’s size, the installation of the specialized equipments for carrying the wheeled cargo was successfully finalized by the DMHI employees, which required high skills and delicate welding. The vessel was delivered upon contractual delivery date, just 12 months after steel cutting and also the total recorded period elapsed after contract signing.

Two low cost power-house offers to increase productivity!!

1-800-245-3186
www.bugo.com

Go-fer III
Cut or Weld in any position

KBUG-1200
Smallest trackless, digital compact fillet welder in the industry

3 Year Warranty

www.eagle.org

Advancing Safety

Driven by Innovation

Safety | Service | Solutions

Offshore Ports

The benefits of Offshore Ports in the U.S. & Africa

BY MARCO PLUIJM, PORTS AND MARINE SECTOR MANAGER, BECHTEL

In many parts of the world, offshore ports are a good solution for meeting the requirements of the rapid changes in the international container and bulk shipping industry. Bigger ships, changing routes and destinations require larg-

er and deeper ports, which port owners and operators can be confident will be capable of handling ever-increasing sizes of vessels for many years to come.

Changing Shipping Routes

One of the major challenges in the current container shipping industry is to

bundle and organize capacity in the most economical way. In terms of vessel size, Maersk is leading with its Triple E vessels, but the capacity of these new, larger ships needs to be combined with other main carriers in order for it to be effective. Various alliances have been formed, and new ones are being developed. As

part of this process, capacity is being shifted to routes which haven't changed for many years, for example in West Africa. Due to the so-called cascading down process, ships which were never originally intended for use in West Africa will now soon be there. Ports like Abidjan are already anticipating these changes and

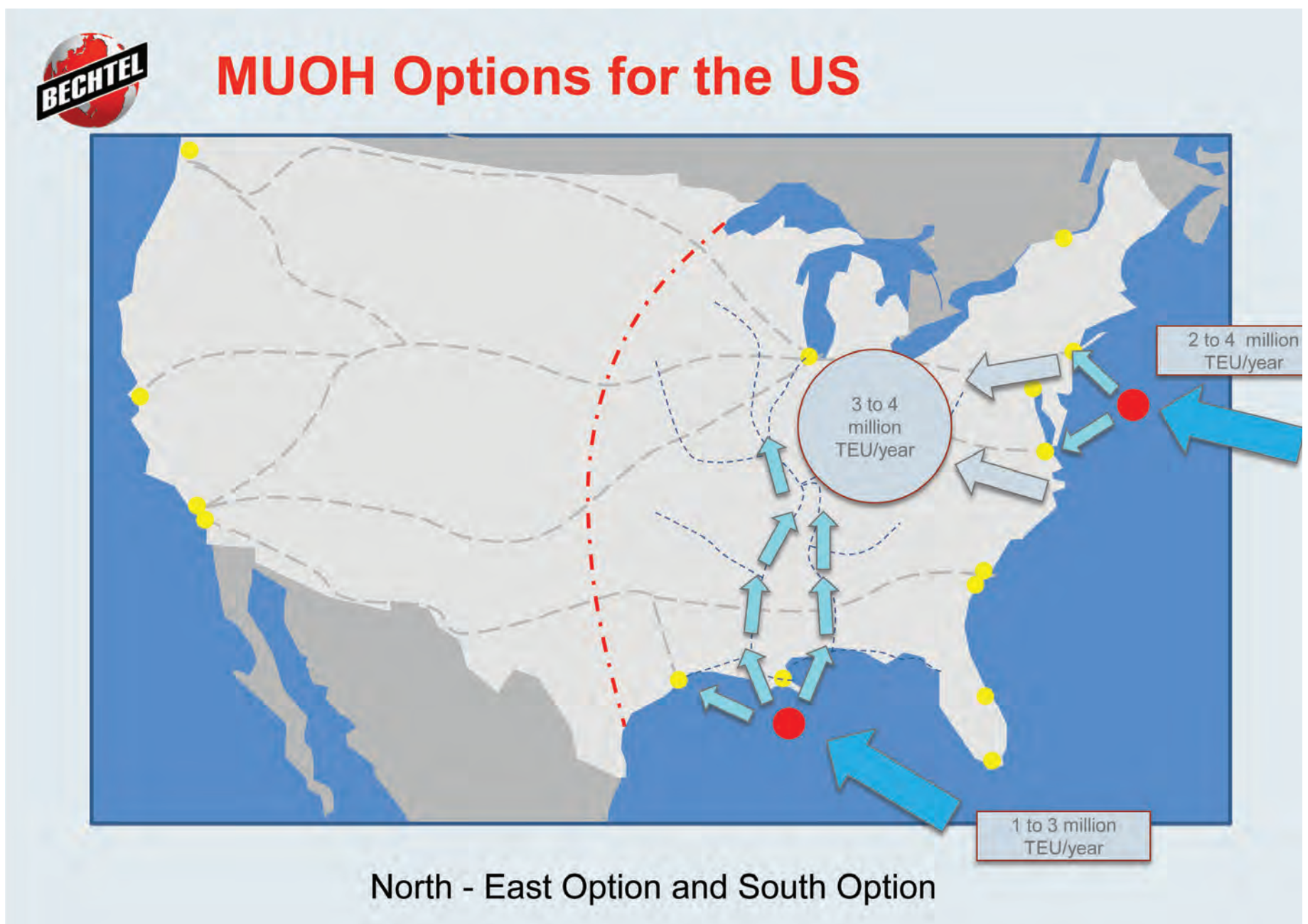

Due to the same cascading effect and the fact that the biggest container vessels can sail direct via the Suez Canal straight to the U.S. East Coast, an option that is rapidly developing as an alternative for the New Panama Canal.

The route via Suez has a greater degree of freedom in terms of ship sizes, especially when the planned increase in two-lane capacity is ready.

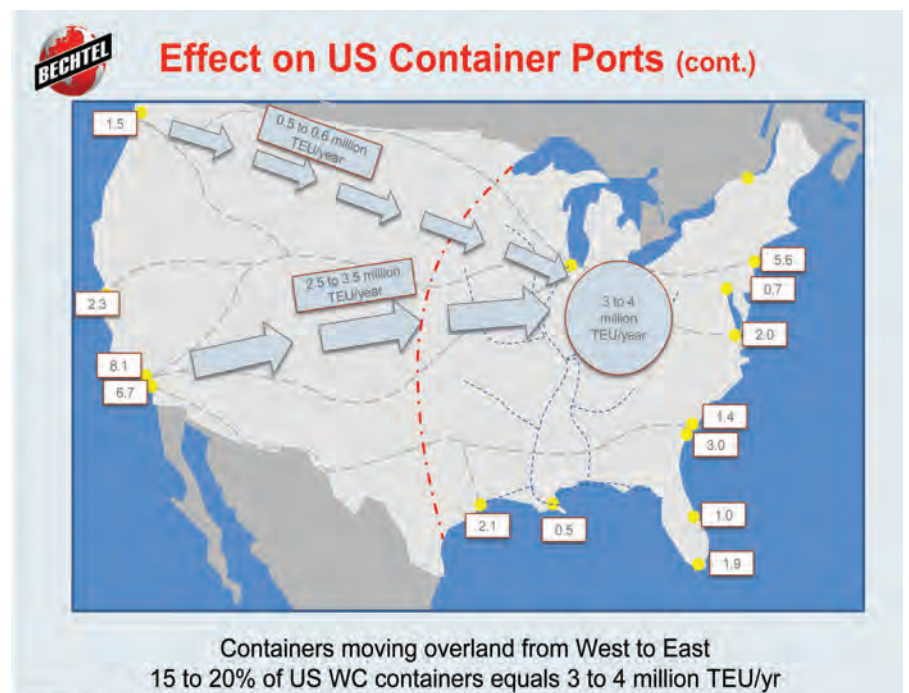
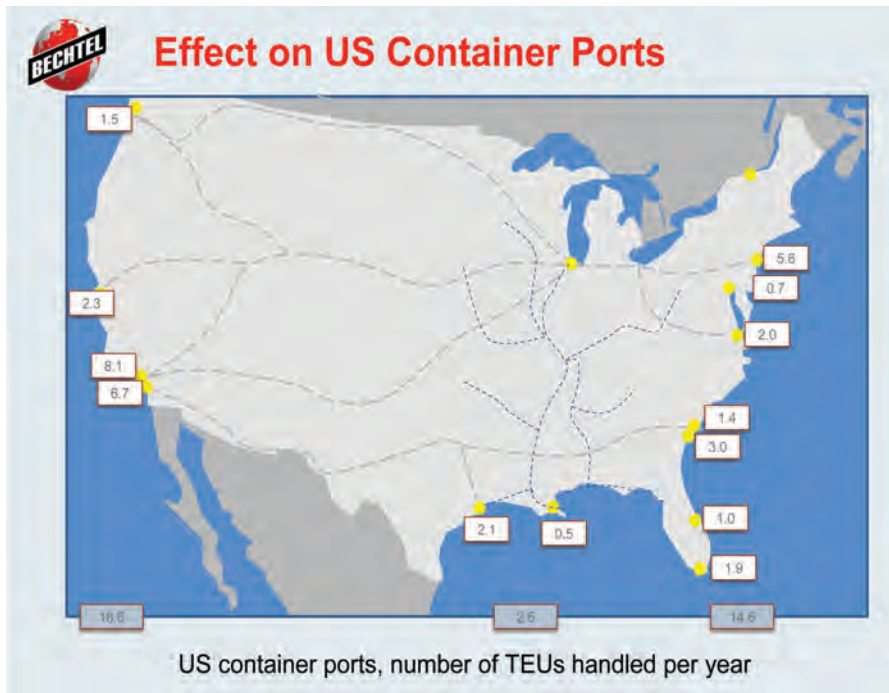

looking at possible solutions. Others are talking about it but haven't really started to tackle the issue yet. However, many of the traditional ports lack the physical possibilities (in terms of size, depth, finance, etc.) to make the changes required to enable them to cater for larger vessels and increased capacity. As a consequence, offshore hubs along parts of the West and East African coasts are a solution: in the Guinea-Liberia region for the export of minerals; in the Cameroon-Gabon region for containers; and in Mozambique for bulk. The benefits are massive. We've predicted that the savings in investment and operational costs could add up to between 40 to 50 percent.

Similar developments can be seen on the East Coast of the U.S. Due to the same cascading effect and the fact that the biggest container vessels can sail direct via the Suez Canal straight to the U.S. East Coast, an option that is rapidly developing as an alternative for the New Panama Canal. The route via Suez has a greater degree of freedom in terms of ship sizes, especially when the planned increase in two-lane capacity is ready. The big question now is if and how quickly the U.S. East Coast ports can

**ANCHOR WINDLASSES - RESCUE BOAT DAVITS
CAPSTANS - ANCHOR WINCHES - MOORING WINCHES
TOW WINCHES - REELS - CONSTRUCTION WINCHES**

COASTAL MARINE EQUIPMENT, INC.
GULFPORT, MS www.cmei.biz (228) 832-7655

AMERICAN MADE

AN INVESTMENT WELL MADE

STOCK (Purchase and Rental):

- Anchors (All Types)
- Anchor Chain and Fittings (New and Used) Grades 2, 3, R4 and R5
- Marine Fenders (Pneumatic and Foam Filled)
- Smit Towing Brackets, Tow Plates, Towing Shackles, Towing Chains and Towing Wires
- LBNO Towing Shackles (Oval Pin), Anchor Line Hooks, "Pee Wee" Sockets, Hawser Thimbles (MADE IN THE USA)
- Heavy Lift Slings, Lift Design and Engineering Services

www.dcl-usa.com
Email: sales@dcl-usa.com
Ph: 800-228-7660 • Fx: 504-947-8557
Available 24/7/365

BECHTEL Main Container Shipping Routes Suez Canal and Panama Canal option



Largest Vessels on route	TEU
Asia - Northern Europe	18,270
Asia - Mediterranean	14,000
Asia - US West Coast	13,800
Asia - US East Coast	8,500 - 10,000 ?
Asia - East Coast South America	9,700
Europe - East Coast South America	8,800
Asia - West Coast South America	9,200
Asia - Middle East	14,000
Europe - South Africa - Asia	12,500

Modified from IAPH/Drewry, April 2014



Applicable Vessel Dimensions	New Panama Canal	Suez Canal	Value
draft	15.3	20	m
width	49	40 to 77	m
length	366	n.a.	m
air draft	58	68	m
# of containers	13,000	n.a.	TEU
DWT	120,000	240,000	DWT
Duration of one channel passage	9 to 10	12 to 16	hours

Modified from R.I.K. Johns & Associates, Inc. 2005.

BECHTEL MUOH Operations

- Purpose built, state of the art, multi-purpose port and/or terminal facility
- Combination of smart high density throughput handling facilities
- Minimal surface area, tailor made for each type and quantity of cargo (containers, wet or dry bulk)
- Situated at adequate water-depth, no dredging required
- Direct serving the main carriers, the coastal shippers and barges, all together
- Direct forward moving cargo, no storage on the MUOH

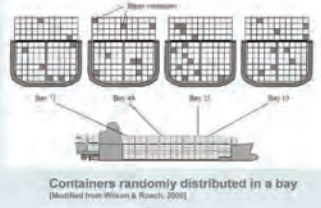

Containers randomly distributed in a bay
(Modified from Whelan & Rowett, 2000)

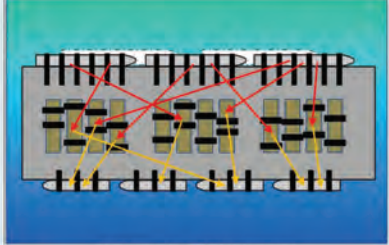

Birdseye view MUOH Terminal

BECHTEL Example of Offshore Port Construction





Photo: DEME, Belgium

BECHTEL Substantial Benefits of having Offshore Hubs



adjust to this development. New cranes have just been ordered and installed for the New Panamax vessel sizes. Some ports have dredged their channels and quays and widened their basins at substantial cost. Others aren't yet ready to do this, which might be an advantage. Investing in an offshore port could be the best solution by providing a hub for a whole region with fewer limitations for long term development than is often the case in existing ports without limitations in free height (draft), which is an issue in New Jersey for instance, or for various environmental reasons.

Are Offshore Ports a Solution?

Some coasts are just not suitable for deep water ports due to their extended shallow foreshore. For a required water depth of say 20 m, a deep water port might need to be 15 km or more away from the shoreline. This is a situation found along large parts of the African

coast, particularly in West and East Africa. So instead of bringing the ship to the port and dredging long and deep channels and port basins on the coastline, one solution could be to bring the port to the ship at the required water depth with an offshore port providing various handling facilities for bulk and/or terminals for containers. Barging the cargo to and from the offshore facility and terminals to nearby coastal or river ports, and using existing corridors and facilities can thus save on capital construction and operational costs. It can also reduce the environmental impact and minimize the ecological footprint. By concentrating present and future development in one spot, an offshore port could work very well not just in Africa but also in the U.S. Currently, up to 70 percent of all West Coast containers move east by rail and road. If only 20 percent of these containers would shift from overland transport to all-water direct import via the Suez

Canal to an East Coast offshore port, this would save:

- 20 to 30 percent on direct freight costs from the Far East to the U.S. East coast due to the all-water economy of larger scale shipping
- 30 to 40 percent (or even more) on direct freight costs due to 40 to 50 percent shorter overland transport distance in the U.S. itself
- 20 to 30 percent in emissions on the all-water-route (lower fuel consumption, more efficient engines) plus a 40 to 50 percent reduction in overland transport emissions.

The estimated overall cost reduction for an East Coast multi-user offshore hub compared to improving existing ports and relying on overland transport to be between 30 to 40 percent for both investment and operations. And lower freight costs could also mean lower consumer prices and therefore be better for the overall economy. Instead of ships

first going via Caribbean hubs, having an offshore port hub in the United States would mean that without extra handling, the industry can keep money and jobs in the U.S.

For the mining industry, using an offshore hub would provide overall better performance and therefore easier overall feasibility of the whole development, which means earlier viability of the development of the whole prospect. Mining projects that weren't feasible in the traditional setting with a rail link and one or more coastal ports can become viable when choosing an offshore hub. Even more so, when in combination with (inland) barging or coastal shipping.

The Concept

In the offshore port model, no dredging is required as the facility is placed in water of sufficient depth, say 20 to 22 meters. In order to avoid or reduce the need for expensive breakwaters, tech-

nologies such as dynamically controlled mooring and proactive fender systems will be used to guarantee safe operations and a sufficient wide operating window for handling the cargo.

For bulk, the degrees of freedom are usually much larger than for containers, which is why these dynamic systems are being used on an increasing number of container terminals all over the world, especially in existing ports with heavy swell issues.

For containers, the offshore hub would consist of a smart terminal arrangement of say two or three berths for the main carriers and four or five for barges to nearby ports and coastal shipping. The facilities can be extended in almost any combination with dry bulk, wet bulk and containers, depending on zoning and safety requirements.

This concept is not entirely new. Bechtel has already built the deep water Khalifa Port and Khalifa Industrial Zone in Abu Dhabi, one of the world's largest combined port and industrial zone developments. However, Khalifa Port is con-

nected to the mainland by a causeway and bridge and the offshore hub proposal is essentially an island. There are similarities in terms of port and terminal operations, as well as scale. The offshore hub would be able to handle up to 4 million TEU per year.

Conclusion

The offshore hub represents a viable solution to the future needs of ports, which need to adapt to the ever-increasing sizes of vessels, particularly in the U.S. and Africa. Offering the opportunity to save costs, minimize environmental impact and increase capacity, this concept could provide the answer where traditional ports cannot. Its prospects look promising. In Africa, the multi-user offshore port concept provides a strategic solution by maximizing the benefits of infrastructure corridors. While in the U.S., Bechtel is currently in discussions with various government agencies about the development of an offshore port on the East Coast.

The Author

Marco Pluijm is responsible for the Bechtel's Port and Marine sector, which includes business and project development, worldwide, technology development, as well as innovation in the maritime sector. He has more than 35 years' experience in planning and building ports across the globe. As part of the innovation cluster, he is currently leading a joint-industry project (JIP) into the safer mooring of large cargo ships in open water, transshipment, along the coast of West Africa. And recently led the highly-acclaimed ROPES JIP research project for the assessment of the quantitative effects of passing ships on moored ships, which resulted in new international guidelines for the design of safer ports. Mr. Pluijm previously worked for a port authority, a dredging company, an international port consultancy and the Ministry of Transport in the Netherlands. He has an MSc Civil Engineering in port planning and design from Delft University of Technology, the Netherlands.

Power Tools for Diesel Engine Analysis.

Model 6320/DA2	Dual-Channel Diesel System
Model 6320/DA1	Single-Channel System
Model 6320/DC	Combustion Analyzer
Model 6320/DV	Vibration/Ultrasonic Analyzer

Boost diesel engine reliability and cut maintenance costs with powerful Windrock analyzers. Proven features like crank-angle-referenced vibration and ultrasonic signatures combined with cylinder pressures provide a complete, component-level view of your engine. So you'll have powerful insight to evaluate engine performance, assess mechanical condition and detect degradation.



[Learn more at www.windrock.com/diesel](http://www.windrock.com/diesel)



Turning Data into Performance
www.windrock.com
 +1 865-330-1100
sales@windrock.com

THE RIGHT CHOICE WHEN YOU NEED TO POWER UP



CD-BMW BARGE/RAILCAR MOVING WINCH

- 3 standard sizes
- Large-capacity drums
- 10-50 horsepower
- Simple design, minimal maintenance

nabrico-marine.com 615.442.1300



NABRICO

Environmental Regulations

Continue to Evolve



Let us help you meet the 2013 Vessel General Permit and the Cleaning Above the Waterline requirements.

Let us show you how to:

- Clean with safe, effective and sustainable products
- Meet current & evolving regulations
- ELIMINATE hazardous hydrocarbon pollution in YOUR workplace



Call or email us TODAY for more details.

Environmental Solution, Inc.

YOUR PARTNERS IN ENVIRONMENTAL RESPONSIBILITY.
totalbiosolution.com
 919-740-0546 | john@totalbiosolution.com

We're looking for DISTRIBUTORS!

Marine Lubricants

New Year, New Emission Rules

January 1, 2015 is an important date for ship owner and operators to ensure that their vessels, when operating inside ECA zones, are doing so in compliance with strict new emission edicts concerning the emission of sulfur. While the effects of low-sulfur fuel on marine engines is well recorded, on the eve of this new legislation we rounded up four executives from marine lubricant companies –

- **Stefan Claußen**, LUKOIL Marine Lubricants
 - **Gianluca Marucci**, Castrol
 - **Jan Toschka**, GM, Shell Marine Products, and
 - **Rik Truijens**, Chevron Marine Lubricants
- to discuss some of the technical and logistical matters you must consider.*

By Greg Trauthwein

The move to low sulfur fuels is well recorded, but from your point of view, describe the situation that ship owners face regarding fuel selection and cylinder lubrication come January 1, 2015?

• **Marucci, Castrol** In general, there are three potential compliance options for vessels operating in ECAs in the short to medium term: the use of scrubbing technologies, converting to use of liquefied natural gas (LNG) or burning 0.1% sulfur fuel. There has been some uptake of scrubbers but to date this has

been limited to operators of ships sailing predominantly in ECAs such as ferries and cruise ships due to the high costs of retrofitting vessels. LNG ticks the box in terms of emissions requirements but the distribution infrastructure is still in the early stages of development. Therefore, we envisage that from 2015, using 0.1% sulfur fuel will be the most practical option.

To maximize operational performance, prevent downtime and limit engine wear, operators need to proactively address fuel and lubrication changes in tandem.

In particular, commonly used higher BN products such as 70BN and 100BN may compromise engine performance if used with 0.1% sulfur fuel on a prolonged basis. This is because BN refers to alkalinity and as sulfur is acidic, the less acidity there is, the lower the level of alkalinity that is required in a lubricant. Yet, with crews stretched and skills gaps on-board, the temptation to stay with an existing lubricant could be high. This is why lubricant manufacturers need to be hands-on in helping operators and their crews to manage the transition to a lower

BN lubricant. Our recommendation for the majority of vessels is a 40BN lubricant with higher levels of dispersancy and detergency additives than in higher BN cylinder oils. So far, we have been in discussion with many operators and they have already started training their crew to meet the challenges of the fuel change over. We are also working with customers to help crew better understand the implications for lubricant application in these scenarios and how to effectively switch lubricants.

Ultimately, the response to the changes



“With the majority of operators clearly appearing to opt for operation on low sulfur distillate fuels, there is an opportunity to improve performance through the use of lubricants specifically optimized for the lower acidity of the new, cleaner and more environmentally friendly fuel.”

Rik Truijens Chevron Marine Lubricants



in sulfur regulations in ECAs from 2015 will present a significant learning curve across the industry, spanning operational, financial and legal implications. Within this, lubricant manufacturers will need to work closely with OEMs and operators to gain a deeper understanding of how lubricants are performing with distillates once use becomes widespread. Castrol has been looking at different technologies for use with 0.1% sulfur fuels as well as with LNG, and will be monitoring in-service performance with customers and OEMs from the start of 2015.

Specifically, this reduction in sulfur content has a trickle down impact across the engine. What does the change specifically mean for marine engines? For their cylinder lubricant?

• **Truijens, Chevron Marine Lubricants** With the majority of operators clearly appearing to opt for operation on low sulfur distillate fuels, there is an opportunity to improve performance through the use of lubricants specifically optimized for the lower acidity of the new, cleaner and more environmentally friendly fuel. With no scrubber installed the maximum sulfur content of the fuel burned while sailing in ECAs will be capped at 0.1%wt. At this relatively low sulfur content, the amount of acids generated during the combustion

process is relatively low. Since the risk of acids condensing on the cylinder liners becomes low accordingly, there is less need for alkalinity (base, BN) in the cylinder oil to neutralize acids. At this point the main task for the cylinder oil is to provide lubrication and keep the components in the combustion chamber clean, rather than prevent from corrosion occurring. And this is exactly what our latest cylinder oil development, Taro Special HT LF, was designed for.

• **Toschka, Shell** On a positive note, most low-speed 2 stroke engines will be able to burn fuels with a much lower sulfur content without needing significant modifications. However, it is important that the right choice of cylinder oil is made. Guidance from the OEMs has been clear in that they expect vessels to switch to a cylinder oil with a lower BN (<40) at the same time as when the customers switch to the very low sulfur fuel. Sustained running on a high BN lubricant with very low sulfur fuel can result in the formation of abrasive deposits on piston top lands, piston rings, piston ring grooves and ring lands. These deposits can disrupt the lubricant film, ultimately resulting in scuffing and cylinder liner damage.

• **Marucci, Castrol** The prolonged use of a high-BN lubricant of around 70BN or 100BN in a low sulphur environment can produce excessive deposit formation

throughout the hot parts of the engine. One area of concern is ash deposition on the crown land which can impact the oil film, and, combined with the lack of controlled corrosion, the liner surface becomes smooth and polished and so unable to hold a stable oil film. If the condition continues, scuffing and total destruction of the liner surface can occur due to metal-to-metal contact.

Frankly, there seems to be plenty of confusion in the market today regarding fuel and lube choices. Please discuss your company's investment & efforts in this regard, specifically discussing the rationale behind the solution you offer.

• **Claußen, LUKOIL** Our aim is to help the operator to manage lubrication of two stroke engines. To this end we have developed iCOLube, an intelligent Cylinder Oil lubrication unit designed to use fresh or used system oil to optimize NAVIGO 100 MCL. The unit tailors the alkalinity reserve of the cylinder oil to the prevailing engine load and fuel sulfur content with the advantage that only one grade of cylinder oil is necessary on board, the engine always stays at its optimum feed rate and the operator only needs to enter the sulfur content of the fuel. With this innovative approach we offer our customers the following benefits: Easy and time-saving operation;

Fuel savings; Maintaining the engine in best condition; Reduced oil costs; Environmentally friendly technology; and, Easy installation.

• **Toschka, Shell** Shell continues to maintain a close collaboration with key industry players, in particular the OEMs; to ensure that we provide solutions that meet the needs of both current and future engines. Specifically, we have chosen to develop a lower BN (BN=25) cylinder oil that has been designed to work with the types of low sulfur fuels that we anticipate being available for customers to meet the ECA requirements from January 1, 2015. In line with the OEM guidance, we believe that this is necessary to ensure continued safe and reliable operation of modern low speed, 2 stroke engines.

What is the biggest challenge for you, as a lubricant manufacturer, to stay ahead of these new regulations and technical demand?

• **Claußen, LUKOIL** To do performance tests of new cylinder oils in real engine after development work while no customer is running the two stroke engine on distillate or gas yet really.

• **Toschka, Shell** The shipping industry is facing a significant growth challenge leading to the industry adopting various cost savings measures such as slow-



“Running long term on the wrong lubricant, e.g. high BN cylinder oil while burning low sulfur fuel or distillate fuel, can increase the level of deposits. The lube oil/unused additives are contributing to the deposits and higher levels of deposits can lead to higher wear rates on ring and/or liner and ring breakages.”

Stefan Claußen LUKOIL



steaming, a drive for fuel efficiencies and low cost operations. The changes in the legislation only compounds the complexities and challenges for Shell as we try and build collaboration with the industry players from the legislators, OEMs to ship owners/operators.

- **Truijens, Chevron Marine Lubricants** The new ECA regulations make the choice for fuel and lubes more critical than ever. As a dedicated supplier to the global shipping industry Chevron Marine Lubricants has invested heavily in the development of appropriate new technology for our lubes. We realized early on that simply reformulating our existing products would not be sufficient – we needed to start again from scratch. We had the enormous benefit of access to a tanker fleet operating in the already tightly regulated Californian waters so have been able to gain extensive proof of performance for our new products in real world sea conditions. Those products are now available globally.

- **Marucci, Castrol** In terms of compliance with the 2015 ECA requirements specifically, the main challenge is that marine gas oil (MGO) has not been widely used so far. 2015 will be a big learning curve for everyone in the industry. Within this, lubricant manufacturers will need to work closely with OEMs and operators to gain a deeper understanding on how lubricants are performing with distillates once use becomes more widespread. Castrol has been looking at dif-



“In terms of compliance with the 2015 ECA requirements specifically, the main challenge is that marine gas oil (MGO) has not been widely used so far. 2015 will be a big learning curve for everyone in the industry.”

Gianluca Marucci Castrol



ferent technologies for use with 0.1% sulphur fuel and LNG for some time and we will be further monitoring in-service performance with customers and OEMs during 2015. In relation to this, we will also have a clearer idea of market demand.

Once the regulations are implemented, we will be better positioned to build a more accurate understanding of just how many vessels are operating in ECAs for a significant period of time and of those, how many will persist with 0.1% low sulphur fuel as an ongoing solution or will look to explore alternative options for reducing sulphur emissions such as use of LNG or abatement technology, such as scrubbing.

More broadly, both regulation and vessel operating conditions are continuously evolving and our challenge is to anticipate future trends and use this to shape the ongoing development of our services and products. This helps us to advise our customers and enable them to manage change pro-actively. The next major change is a planned global cap of 0.5% sulphur in 2020 which will mean further changes to cylinder oils.

What are the problems a ship owner / operator might expect should they make the wrong choice of cylinder lubricant?

• **Claußen, LUKOIL** Running long term on the wrong lubricant, e.g. high BN cylinder oil while burning low sulfur fuel or distillate fuel, can increase the level of deposits. The lube oil/unused additives are contributing to the deposits and higher levels of deposits can lead to higher wear rates on ring and/or liner and ring break-ages.

• **Toschka, Shell** The choice of the right cylinder oil is crucial in ensuring the engine performs to its intended purpose, delivers efficiencies and maintains reliability. The wrong choice of lubricant could significantly im-

part the engine potentially resulting in cold corrosion and/or deposits build-up ultimately impacting the performance of the engine and leading to hardware damages.

Put in perspective if you will, how the reduced emissions drive in maritime has impacted the overall business of your company. Is this revolutionary and unique, or is this simply an extension of similar challenges faced in other transport modes years ago?

• **Claußen, LUKOIL** The increased focus on environmental issues and emission reduction has an impact, of course. If regulations regarding the fuel sulfur content change, lubricants have to be developed which match the new fuel qualities. Furthermore, the general

awareness of customers for environmental issues has risen and we see growing demand for environmentally friendly solutions such as iCOLube, whose environmental impact has been studied in a Life Cycle Assessment (LCA): Not only does it allow for easy engine operation, oil savings and improved engine maintenance, but can also reduce fuel consumption by up to 1% and enables a 13% reduction of CO2 equivalent compared to conventional ship operation. By way of comparison, over one year a fleet of 12,500 ships will save more than 525,000 tons of CO2 equivalent, which is equivalent of taking 225,000 passenger cars of the road.

• **Marucci, Castrol** The focus on emissions reduction has influenced our offering as it is essential that we provide a high performing lubricant and specialized

Commercial Sales Division
Ph: (715)394-4444
Fax: (715)394-6199
sales@lidgerwood.com
http://www.lidgerwood.com

**THE LATEST TECHNOLOGY IN
COMMERCIAL DECK EQUIPMENT**



“The shipping industry is facing a significant growth challenge leading to the industry adopting various cost savings measures such as slow-steaming, a drive for fuel efficiencies and low cost operations. The changes in the legislation only compounds the complexities and challenges for Shell.”

Jan Toschka Shell Marine Products



support services to ensure that our customers use the right lubricant with low sulfur fuels. It is also critical that we help them to plan for this transition. The 2015 ECA regulation changes are a major milestone but further reductions to SOx, NOx and particulate matter will continue to drive change, including the types of fuels that will be used to meet increasingly stringent targets. Additionally, the focus on CO2 emissions reduction is also driving the development of more fuel efficient engines. A direct result of this has been the need for high BN oils to combat corrosion. We therefore need to help customers manage the complexity of using different lube oil types to cover the wide range of demands from today's operational environment.

This means that we can never stand still and need to continue looking forward and innovating so that we can meet customers' future requirements. While other transportation sectors have faced similar challenges in the past, the shipping industry has its own unique set of considerations. Undoubtedly, this is a significant period of change as improving environmental performance is set within the context of a broader commercial context. Optimizing efficiencies, achieving cost-reductions and improving overall profitability are absolute priorities for the industry at present. At the same time, the 2015 European and North American 0.1% sulfur caps as well as other medium-term emissions legislation, pose further operational and finan-

cial considerations. Simultaneously, ship operators still face shortages of skilled crews that are on the front-line for managing and implementing some of these day-to-day changes on board vessels. This highlights the complexity of the issue. However, shipping has proven itself to be a robust and adaptable industry throughout history. I am confident, that with the right support, the industry will rise to the challenge.

Put in perspective the increased cost of these new solutions for cylinder lubricant. How much more is a “typical” ship owner paying in 2015 vs. a few years ago, looking at the same ship and route?

• **Claußen, LUKOIL** To put a number on it, we need more experience with iCOLube in the low BN range and running on distillate fuel. However, the iCOLube helps to maintain or even reduces the cost of lubrication, reduces wear and can reduce fuel cost up to 1%. The optimization of 100 BN cylinder oil with fresh or used system oil saves oil and costs as well and further savings will derive from wear reduction (e.g. less spare parts).

• **Marucci, Castrol** We can't comment on our pricing but according to Moore Stephens' Future Operating Costs Survey 2014 which was issued in October,

ship owners and operators expenditure on lubricants is expected to rise by between 1.7% in 2014 and 2% in 2015, depending on the sector. For many operators any higher cost associated with newer cylinder oils has been more than compensated for by slow steaming which has reduced consumption significantly.

• **Toschka, Shell** There is no doubt that the reduced emissions drive in the marine industry has increased complexity for both our customers and us. From our perspective, we have needed to develop and maintain multiple products to meet all the different customer requirements. In addition, we see an increased need for technical support – be that in offering used oil analysis programs, helping to interpret and implement OEM requirements, cylinder condition monitoring or in assisting in crew development.

Right now, what do you see as the biggest mistake a ship owner / operator could make in moving forward with their marine fuel and lube choice?

• **Truijens, Chevron Marine Lubricants** Choosing the wrong combination of lube and fuel exposes shipping operators to the risk of excess engine wear – and this applies both inside and outside the ECAs. Choosing a lube with excess BN or alkalinity in combination with low sulfur fuel can result in in-cylinder

deposits leading in turn to scuffing problems and thus excess wear. The application of a cylinder oil with excess alkalinity (BN) in combination with low sulfur fuel can result in excessive deposit formation on pistons, fouling of the scavenge space and exhaust tract and can lead to excessive wear and even scuffing if maintained for prolonged period of time.

Go the other way and choose a low BN product with typical bunkered fuel (which may have up to 3.5% sulfur compared with the just 0.1% allowed in ECA areas) then excess acidity can lead to accelerated corrosion and engine component wear.

The secret is getting the alkalinity/acidity balance in the combustion chamber right. Our new 100 BN oil, introduced earlier this year, aims to produce the optimum balance in the new generation of engines operating at ultra low rpm speeds.

We work in partnership with our ship operating customers to ensure the right balance and lube dosing levels whatever the conditions. We stress the value of incorporating a cylinder drip oil analysis program to continually monitor iron wear levels in this regard. Particularly, a drip oil program that measures both magnetic and corrosive iron. Our long term drip oil analysis program – conducted on board and on shore – has more than seven years of history and is a proven, OEM-endorsed tool to oversee that critical balance.

Mobilgard 525

New cylinder oil for two stroke slow speed engines to facilitate compliance with the 0.1% sulfur fuel in the ECAs.

At SMM in Hamburg ExxonMobil launched Mobilgard 525, a cylinder oil with a 25 Base Number (BN) that is specifically engineered for use with fuel containing 0.1% sulfur, and approved by MAN and Wärtsilä for use in two stroke engines.

“This will enable the two stroke slow speed engines to run effectively on low sulfur fuel, as the cylinder lube available currently, the BN level is simply too high,” said Iain White, Global Field Marketing Manager, ExxonMobil Marine Fuels & Lubricants.

Ships entering Emission Control Areas (ECAs) after January 1, 2015 must use fuel with a maximum 0.1% sulfur content. Though the transition has been widely publicized globally, there remains confusion and resistance among ship owners. ExxonMobil, with its Mobilgard 525, seeks to ease the transition.

If the BN of your cylinder lubricant is too high, “the hot areas of the piston, which is the piston crown and

the top of the sides you get deposit build up if the BN is too high in conjunction with the low sulfur fuel, because you’re not using that additive for neutralization purposes ... you simply don’t need it. So it plates out on the piston and causes wear,” White explains.

The 25 BN formulation has been engineered using high quality base oils and an advanced ‘balanced formulation’ approach. To put it simply, it’s all a matter of chemistry.

“The challenge is that the chemistry that goes into the product to do all of that neutralization is also the chemistry that (helps to keep the engine clean),” said White. “So as you take that out to reduce the deposits, you have to struggle to keep your engine clean, and your problem moves from the crown lands where you get deposits back to the ring pack where it gets very dirty. We’ve cracked that challenge by balancing the chemistry so that the oil does its job; deposits are

minimized and the engine stays clean.”

With an avalanche of new rules regarding emissions from diesel engines coming into force starting now and extending through 2020, the fuel and lube buy and procedure for ship owners promises to get even more convoluted.

“It’s really a complex picture,” said White, noting that the roster of choices includes fuel switch-over in ECA zones, the use of distillates, outfitting ships with scrubbers or incorporating a growing list of alternative fuels, starting with LNG. “From ExxonMobil’s perspective, instead of bringing a new product out and going to the customers to talk about the new product, we first of all go to the customer to talk about their challenge. For example we’ve made an insights film into the cold corrosion issue, because we’re finding that people don’t understand that. We do the training first.”

YOUR NEXT HOLE STARTS WITH HOUGEN



Mag Drills & Annular Cutters

Hougen has the power, performance and reliability that you demand from your tools backed by the company that built them.

Hougen

800-426-7818 • www.HOUGEN.com

RUSTIBUS® maintaining your values

SAFE EDGE BY RUSTIBUS

WIDE RANGE OF DECK CRAWLERS.

Rustibus® is designed to **de-scale and power brush** ship decks, hatch covers, tank tops, etc. free from paint and rust!



THE MAN-HOLE PROTECTION COVER.

This unique cover is specifically designed to allow ventilation and utilities to be accessible while providing an effective fall prevention system to protect the crew from those easily overlooked dark holes in the deck.



housten@rustibus.com
Ph: 832 - 203 - 7170

www.rustibus.com

STAY AHEAD with the best

Maritime Associates, Inc.
Marine & Offshore Signage Experts

Signs

We Design, Produce and Install all signs and complete sign systems

775-832-2422
www.MaritimeSigns.com
maritime@MaritimeSigns.com



Put the power of our experience to work for you

ANCHORS

ANCHOR MARINE CHAINS

LARGEST INVENTORY OF NEW & USED IN THE U.S.A.

FAX: 713/644-1185
WATTS: 800/233-8014
PHONE: 713/644-1183

P.O. BOX 58645
HOUSTON, TX 77258

ALL TYPE ANCHORS & CHAIN
ABS, LLOYDS
GRADE 2, 3, K-4
CHAIN & FITTINGS

sales@anchormarinehouston.com
www.anchormarinehouston.com





Bajpae



Fireman



Tsakos



Sadler



Leavitt



Atteridge



Hobbie III



Langh-Lagerlöf



Dugas



Alfultis



Bagley



Wilson

Bajpae Honored

Rajaish Bajpae, CEO of Bernhard Schulte Shipmanagement, received the Tanker Shipping & Trade Lifetime Achievement Award. As head of Bernhard Schulte Shipmanagement, Bajpae has overall responsibility for a fleet of more than 600 ships of various types, 20,000 employees and maritime service, crew management and training centers in over 30 locations around the world.

Fireman Wins David W. Taylor Medal

SNAME awarded its highest technical honor, the David W. Taylor Medal for notable achievement in naval architecture or marine engineering, to **Howard Fireman**, ABS Senior Vice President, Asset Performance Management (APM). After serving 35 years in the U.S. Navy, Fireman joined ABS in 2013, taking responsibility for the ABS APM group, which helps the marine and offshore industries meet environmental regulatory requirements and assess the operational performance, energy efficiency and fuel consumption of new and existing vessel designs.

Tsakos to Lead INTERTANKO

INTERTANKO announced that when its Council of Members met this week in Dubai it elected **Nikolas Tsakos** – President and Chief Executive of Tsakos Energy Navigation – as Chairman, succeeding Graham Westgarth who steps down after five years in post.

LR CEO Richard Sadler Honored

Richard Sadler, CEO of Lloyd's Register Group Ltd (LR), was honored with the Maritime Fellowship Award at the Maritime Foundation's Maritime Me-

dia Awards. The Maritime Fellowship Award is the highest honor bestowed by the Maritime Foundation to an individual who has made a truly outstanding contribution to stimulating public engagement in maritime issues.

Northrop Grumman Names Leavitt

Northrop Grumman Corporation named **Todd Leavitt**, vice president of the company's Maritime Systems business unit, effective immediately. Leavitt will have executive responsibility for all Maritime Systems programs and products.

Atteridge Retires from Furuno USA

After 30 years of service to Furuno USA, Inc., **Jim Atteridge** is retiring as President and assuming a new role, as Director and Corporate Advisor. Effective December 1, 2014, Brad Reents will assume the role of President and CFO of Furuno USA, Inc. In addition:

- **Dean Kurutz** has been promoted to the new position of Vice President of Sales, Marketing and Product Planning;
- **Francine Murphy** has been appointed to Director of Human Resources;
- **Rick Walls** assumes the new position of General Manager;
- **Matt Wood** has been promoted to the position of National Sales Manager.

WQIS President Hobbie to Retire

WQIS said that **Richard Hobbie III** will retire from his position as President & CEO of the Water Quality Insurance Syndicate (WQIS) after four decades as underwriter, claims manager and board member. Hobbie and the board of managers have agreed upon January 1, 2015 as his official retirement date, and he will be available as a consultant

to WQIS until Dec. 31, 2017 under the agreement. **John Ryszetyk III**, SVP, will be promoted to President of WQIS. **Andy Garger**, VP & General Counsel, will be promoted to Senior Vice President & General Counsel. **John Moy**, VP, Underwriting, will be promoted to Senior Vice President & Chief Underwriting Officer.

Genco Names Wobensmith President

Genco Shipping & Trading Limited said that **John C. Wobensmith**, the company's CFO has been appointed as President effective December 19, 2014. He succeeds **Robert Gerald Buchanan**, who will retire as of the same date. Buchanan has served as President of Genco since June 2005. The company also announced that **Apostolos Zafolias** has been appointed as CFO and **Joseph Adamo** has been appointed as Chief Accounting Officer.

Langh Ship Elects New MD

Oy Langh Ship Ab will receive a new managing director at the beginning of 2015, when the current managing director, **Hans Langh**, takes over as Chairman of the Board for the shipping company. **Laura Langh-Lagerlöf**, 33, has been elected as the company's new managing director, effective January 1, 2015. "Laura has essentially been part of running the company for a long time already, but now she will be assuming the full responsibility of managing director. My focus now will be on introducing scrubbers in ships," said Hans Langh. The shipping company has five multi-purpose vessels, three of which are used to transport Outokumpu's steel products and two for the container-shipping ser-

vices of Containerships Ltd. The company additionally has roughly 1,000 in-house-designed special containers, mostly for transporting steel.

Keenan Named VP at Gibbs & Cox

Gibbs & Cox, Inc. appointed **Patrick J. Keenan** as Vice President, Platform Solutions Group. In this role, Keenan will have responsibility for leadership and management of the company's government and commercial ship design solutions across the Gibbs & Cox global portfolio. Prior to joining Gibbs & Cox, Inc., Pat served as Global Operations Director for Crowley/Titan Salvage.

Laborde Hires Dugas

Laborde Products hired **Bobby Dugas** as its general service manager, company president **Brian Laborde** announced. Dugas has more than 25 years of experience in the engine service business.

SUNY Maritime Inaugurates Alfultis

SUNY Maritime College inaugurated **Rear Adm. Michael A. Alfultis, Ph.D.** as its 11th president in early November. The campus celebrated the investiture of Dr. Alfultis with a variety of activities, which embraced the time-honored traditions of learning and leadership.

Bagley Named VP at Newport News

Ray Bagley has been appointed by Huntington Ingalls Industries (HII) as the company's new vice president of trades operations for its Newport News Shipbuilding division. Bagley, who earned the distinction of "Master Shipbuilder" for 40 years of continuous service, began his career at The Apprentice School as a painter.



Anzelone

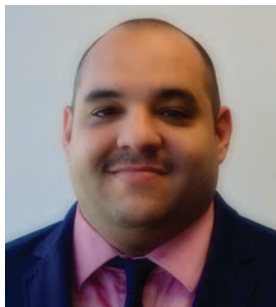

Ramirez



Smith



Doyle



Pevey



Rodriguez

Ince Plots Leadership Succession Plan

Ince & Co, an international commercial law firm, announced that, after two terms in office, **James Wilson** will be stepping down as International Senior Partner in January 2015. Under new arrangements, Wilson will be succeeded as International Senior Partner by **Jan Heuvels** and **Paul Herring** will assume the new role of Chairman.

Faststream Adds 8 Recruiting Staff

Faststream hired eight recruiters in its Houston and Fort Lauderdale offices to focus solely on placing talent within the oil and gas and maritime sectors, reflecting the market needs and industry demands for qualified, experienced and well-trained talent.

"Adding eight new team members in a single month is a huge testament not only to the industries' need, but also to Faststream's ability to provide everything our clients need, from specialty

workers to proper insurance policies and more," said Eric Peters, U.S. managing director for Faststream.. "We seek to grow by another 25 percent in the U.S. by April 2015, especially as inquiries for the placement of offshore, supply yard and drilling crew staff increases."

Faststream's newest hires include: **Shonda Cirotto** – Houston; **Bradley Grace** – Houston; **Criston Hall** – Houston; **Sara Mione** – Houston; **Brian Van Brunt** – Houston; **Brendan Anzelone** – Ft Lauderdale; **Rafael Ramirez** – Ft Lauderdale; and **Gregory Smith** – Ft Lauderdale.

Doyle Named to SGMF Training and Competency Working Group

The U.S. Maritime Research Center in Middletown, RI, announced that **Margaret Kaigh Doyle** has been named the U.S. vice chairperson of the Training and Competency Working Group for the Society for Gas as a Marine Fuel (SGMF).

Pevey Named Sales Director

Mike Pevey has joined Becker Marine Systems as director of sales, responsible for managing Becker's range of high performance rudder and maneuvering systems in North America. Becker Marine Systems recently announced the opening of its newest global office in North America. Located in Houston, Pevey will man the office, providing local service to the marine industry.

Rodriguez Appointed at MarAd

Mike Rodriguez, U.S. Merchant Marine Academy Alum, was sworn in as Deputy Administrator of the U.S. Department of Transportation Maritime Administration (MARAD). Rodriguez has more than 35 years experience as a maritime industry professional in both the public and private sectors. He joins MARAD from the Navy's National Maritime Intelligence-Integration Office. Prior to that, he served in the Military Sealift Com-

mand and in other active duty tours in the Navy.

WSS Brazil Names Carvalho GM

Wilhelmsen Ships Service (WSS) has appointed Antonio Carvalho Junior as its new General Manager for Brazil. A former mariner, Carvalho brings 26 years of direct industry experience to this role from previous positions in logistics, shipping and ships agency.

DNV GL, N-KOM to Partner on LNG

A MOU was signed between DNV GL and Qatar's Nakilat-Keppel Offshore & Marine (N-KOM) to promote liquefied natural gas (LNG) as fuel within the maritime and offshore industry. As part of the agreement DNV GL and N-KOM will cooperate on the development and newbuilding of bunker barges, of coolant barges for temporary gas storage as well as to promote the use of LNG as fuel in the offshore sector.

Media Buyer Tip #3

Magazine Circulation Doesn't Age Well



Only advertise in magazines with a circulation age of 1 or 2 years.

The average employee only spends 4 years at a Job.* Check the audit report to verify your advertisement is being seen by the correct people, not just an old mailing list.

*forbes.com "Job Hopping Is the 'New Normal...'"

MARITIME REPORTER AND ENGINEERING NEWS Since 1939

*BPA Audited
100% Registered
100% 1 or 2 year circ*

Are Stray Electrical Currents Destroying Your Machinery?

Sohre SHAFT GROUNDING (EARTHING) BRUSHES are used on propeller shafts, turbines, generators, electric motors, gears, pumps, etc. Failure to properly ground (earth) rotating shafts can result in expensive damage to seals, bearings, or other critical components.

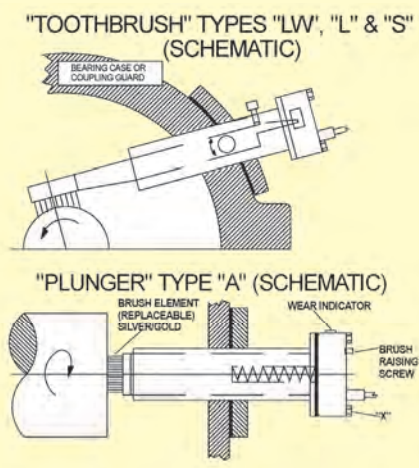

- Self Cleaning
- Operate dry or with oil
- Gold/silver bristles
- Working parts are removable during operation
- Brush internals are insulated from casing
- Voltage and current monitors are available
- Little or no maintenance

© 2013 Sohre Turbomachinery, Inc.

SOHRE TURBOMACHINERY® INC.
Monson, Mass., USA 01057 • Tel: (413)267-0590
INFO@SOHRETURBO.COM • WWW.SOHRETURBO.COM

ISSUE

EDITORIAL

BONUS DISTRIBUTION

JANUARY

Ad Close: Dec 19

Ship Repair & Conversion Edition

Market: Maritime Propulsion: Gears, Thrusters, Waterjets & Propellers
Technical: Marine Salvage & Recovery
Product: Marine Electronics Equipment & Supplier Guide
Country Report: France & Poland

PVA MariTrends 2015
January 31 - February 3 Long Beach, CA
EuroMaritime
February 3 - 5 Paris, France

FEBRUARY

Ad Close: Jan 21

Cruise Shipping Edition

Market: Ships of War: Evolution and Future of U.S. Navy Technology
Technical: Marine Telematics: Data, Tracking and Communications
Product: Marine Coatings & Corrosion Control
Country Report: Denmark, Finland & Sweden

Cruise Shipping Miami - Mar 16-19, Miami, FL
ASNE DAY - March 4 - 5, Crystal City, VA
NACE Corrosion - March 15 - 19, Dallas, TX
Arctic Technology Conference - March 23-25
Copenhagen, Denmark

MARCH

Ad Close: Feb 20

U.S. Coast Guard Annual

Market: Training & Education: From Simulation to Distance Learning
Technical: Oil Spill Response & Recovery
Product: Marine Propulsion: Green Marine Fuels & Lubricants and Emission Technologies
Country Report: Greece & Turkey

CMA Shipping 2014
March 23-25, Stamford, CT
Sea-Air-Space
April 13-15, National Harbor, MD

APRIL

Ad Close: Mar 20

Offshore Edition

Market: Modern OSV Design & Technology
Technical: Workboat Fleet Maintenance & Repair
Product: Deck Machinery, Winches and Ropes
Country Report: The German Maritime Cluster

Offshore Technology Conference (OTC)
May 4-7, Houston, TX
Workboat Maintenance & Repair
April 14 - 16, New Orleans, LA
Marine Money Houston
Houston, TX

MAY

Ad Close: Apr 21

The Marine Propulsion Edition

Market: RIB & Patrol Boat Report
Technical: Workboat Design & Construction
Product: Satellite Communication Technologies
Country Report: The Norwegian Maritime Cluster

Norshipping - June 2 - 5, Oslo, Norway
Inland Marine Expo - June 15 - 17, St. Louis, MO
MACC 2015 - May/June, USA
Seawork - June 16-18, Southampton, UK

JUNE

Ad Close: May 22

Annual World Yearbook

Market: Maritime Simulation & Training Centers
Technical: Dredging: Deepening the Channels of Trade
Product: Pumps, Valves, Pipes & Insulation
Country Report: U.K. & Ireland

Marine Money Week
June 16-18, New York, NY

JULY

Ad Close: Jun 21

Marine Communications Edition

Market: Classification & Ship Registry
Technical: ECDIS System Review & Report
Product: Maritime Tools: Welding & Cutting
Country Report: Italy

AUGUST

Ad Close: Jul 21

Shipyard Edition

Market: Offshore Deepwater: Structures and Systems
Technical: Heavy Lifting Solutions: Maritime Cranes
Product: Ballast Water Technology
Country Report: Russia, Lithuania, Latvia & Estonia

Offshore Europe
September 8 -11, Aberdeen, UK
NEVA
September 22 - 25, St. Petersburg, Russia

SEPTEMBER

Ad Close: Aug 21

Offshore Energy Technologies

Market: Maritime Security Technology & Technique
Technical: Maritime Propulsion: Efficient Drivers
Product: Clean Water Technologies
Country Report: Spain, Portugal & Brazil

OTC Brazil
October 26 -29, Rio de Janeiro
GasTech
October 27 - 30, Singapore

OCTOBER

Ad Close: Sep 21

Marine Design Annual

Market: Ship Classification Societies
Technical: Marine Firefighting, Safety & Salvage
Product: CAD/CAM
Country Report: The Netherlands & Belgium

SNAME
November 4-6, Providence, RI
Europort
November 3-6, Rotterdam, Holland
Clean Gulf
November 10-12, New Orleans, LA

NOVEMBER

Ad Close: Oct 20

Workboat Edition

Market: LNG Handling and Transportation
Technical: Deck Machinery, Winches & Ropes
Product: Fuels, Lubricants & Additives
Special Report: Gulf of Mexico Builder & Supplier Guide

International Workboat Show
December 2-4, New Orleans, LA
Marintec China
December 1-4 Shanghai, China

DECEMBER

Ad Close: Nov 20

Great Ships of 2015

Market: The Automated Ship: Command & Control
Technical: Shipyard Automation
Product: Marine Engine Guide
Special Report: Korea/Singapore/Vietnam

Surface Navy Association 2016
January, Crystal City, VA

Phoenix EcoMod 450 Floodlight

Phoenix Products Company Inc. introduced the EcoMod 450, the latest addition to the company's EcoMod Series of LED floodlights. With an output of up to 41,250 lumens, the EcoMod 450 replaces up to 1,500W HID floodlights and easily retrofits to existing Phoenix installations. The EcoMod 450 uses EcoVent Technology that extends the life of the fixture by allowing heat, water and debris to flow between the modules, Phoenix said. The EcoMod 450 is ETL listed to UL 1598 and 1598A, CE certified and designed for an IP66 rating.



www.phoenixlighting.com

MES & Quiet Performance

Viking Yachts worked with Marine Exhaust Systems to introduce a convertible sportfishing yacht with a resin-infused hull, the new Viking 92, which employs Marine Exhaust Systems' TL Linear Series mufflers to keep the roar of the twin 2,635 hp Tier 3 engines at bay. A muffler in a tube, the design of Marine Exhaust Systems' patented Linear Series muffler technology are adaptable to the size and horsepower of today's modern sportfishing boats, and require less space, creating room for larger fuel tanks or equipment. The Linear Series is suited for an inline application, preferably close to the engine with enough room for a surge tube in front.



www.marine-exhaust.com

Air Purifying System



When a 36-m tugboat was converted into a superyacht for polar expeditions, added comfort meant new luxury materials and furniture, but also a state-of-the-art HVAC system and sound

and fire protected walls. But an occurring smell from the diesel and sewage tank caused comfort restriction on the newly created sun deck and in the cabins while operating the HVAC systems. Adtim solved these problems by installing two dedicated air purifying systems based on smart plasma technology, one for the HVAC system and one for the air outlet of the sewage treatment plant. The AirPurifier for the HVAC has a capacity of 1,800 cu. m./hr.

www.adtim.nl

Norsafe for Pieter Schelte

The Norsafe JYN100 is a conventional Totally Enclosed Lifeboat (TELB) designed and built in accordance with the latest NORSOK R-002 standards, with a capacity of 106 persons. The hydraulic davit systems are designed for platform installation/decommissioning and pipelay vessel Pieter Schelte, a 382 x 124-m-wide dynamically positioned platform installation is specially constructed for demobilization of offshore installations, such as removal of platform decks.

www.norsafe.com



EnviroLogic: SVGP Compliant Fluids & Cleaners

RSC Bio Solutions said that its EnviroLogic Environmentally Acceptable Lubricants (EALs), including hydraulic, stern tube and thruster oils, and SAFECARE cleaners and their constituent components have been evaluated by independent laboratories to meet the U.S. Environmental Protection Agency (EPA) definitions of biodegradable, minimally toxic and not bioaccumulative. RSC Bio Solutions provides a complete range of high performing chemistries and specialty products that are designed to extend the life of equipment and tools.



www.rscbio.com

ExxonMobil Zinc-Free Marine Engine Oil



ExxonMobil introduced Mobilgard 410 NC, touted by the oil company as a zinc-free high-performance oil designed to offer improvement in piston cleanliness, reduction in liner wear

and an enhancement in bearing protection. In testing conducted in extreme service conditions with both EMD and GE marine engines, the company reports that Mobilgard 410 NC technology performed well. Based on the field trials Mobilgard 410 NC is now approved for use in EMD and GE engines. It also meets the requirements for Detroit Diesel, Alco and Fairbanks Morse marine diesel units.

Water Reclamation System for Rig

ACT2 delivered a WRS-40 water reclamation system to Transocean for the Polar Pioneer. The unit will operate in Alaskan waters and produce bacteria and virus free reuse quality water for 40 persons on the rig. Soon after delivery, Transocean ordered four additional units to be delivered in December 2014 and January 2015. Three of these units will handle 200 persons and the fourth will handle 30-40 persons.

www.act2tech.org

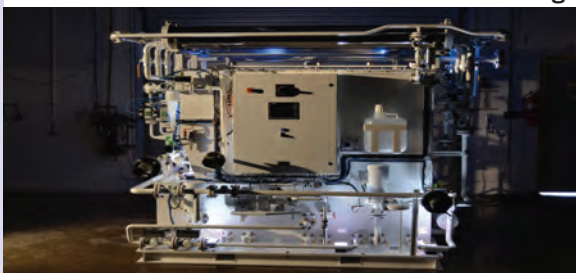

RescueME EPIRB1



The rescueME EPIRB1 from Ocean Signal purports to be smaller, longer lasting and more affordable. The new rescueME EPIRB1 measures just 178mm (height with antenna stowed) by 89mm and weighs 422g. It comes with a 10-year battery life, and it retails for about \$385.

www.oceansignal.com

Shell NATURELLE

Shell Naturelle Stern Tube Fluid

Shell launched a new range of Environmentally Acceptable Lubricants (EALs), including Shell Naturelle S4 Stern Tube Fluid 100, a line designed to enable ships entering U.S. waters to comply with the revised 2013 Vessel General Permit (VGP). Shell Naturelle S4 Stern Tube Fluid 100 is made with fully saturated ester base oil, as the oil major contends that this offers the best resistance to hydrolysis and oxidation. It is also a non-emulsifying fluid, which allows ship operators to easily drain any water from the stern tube system, preventing hydrolysis and biodegradation of the oil within the equipment.

NEW FROM INTERNATIONAL FLOATING PRODUCTION ANALYSIS OF FUTURE BUSINESS DRIVERS

Order Your Floating Production System Report Today!

No other single source provides to you the depth and breadth of information found in the Floating Production Systems Report.

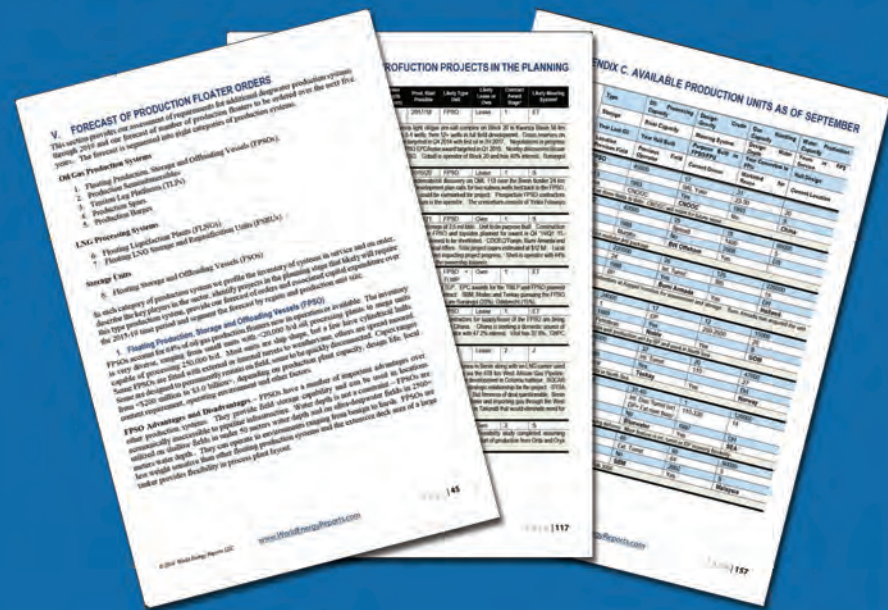
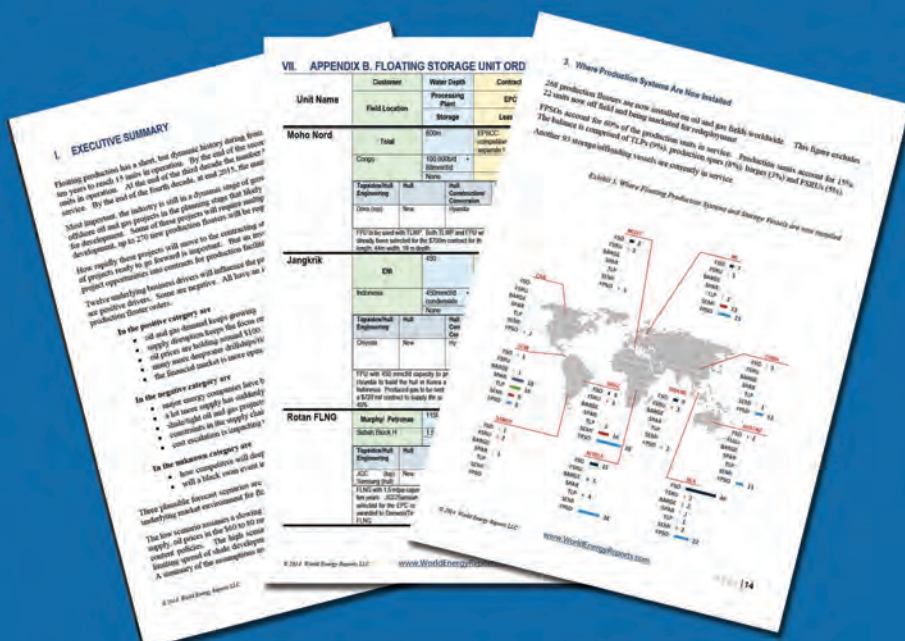

The highly anticipated production forecast will give you insider access to the multi-billion dollar market.

About IMA

Jim McCaul, Managing Director and founder of International Maritime Associates (IMA) has produced 50 multi-client industry reports on the floating production sector over the past 18 years. IMA's "floater reports" have been a widely cited reference source in the offshore industry, and our annual forecast of equipment orders has been widely referenced in investment presentations, industry publications and other consulting firm reports.

Order your report at
www.worldenergyreports.com
tel: +1-212-477-6700 fax: +1-212-254-6271
reports@worldenergyreports.com

MARITIME ASSOCIATES

PRODUCTION SYSTEMS

TRENDS & FORECAST OF ORDERS 2015 - 2019

THE REPORT INCLUDES:

Annual Report

120 pages of Analysis, Data, Charts and Information, all geared to provide you with the biggest, best and most comprehensive resource so that you can long-range plan to capture your fair share of the burgeoning Floating Production System market.

Insightful Updates

Monthly "What's New" report which refreshes the data and analysis. Six months after the Annual Report World Energy Reports will recalculate, factoring in the world economy, market conditions and future prospects for growth.

Database

Every day – 24/7/365 – the World Energy Reports team updates critical data and statistics; Yours for the taking.

Contacts

An industry exclusive, here you receive all of the critical project contacts in one tidy format. Invaluable information.



- ▶ Complete Floating Production Report with 24/7/365 access to data online as it is updated
- ▶ Monthly "What's New" Report
- ▶ Full Project Contact Details
- ▶ IMA's 30+ years expertise in this market

Order your report at
www.worldenergyreports.com
tel: +1-212 -477-6700 fax: +1-212-254-6271
reports@worldenergyreports.com

BUYER'S DIRECTORY

This directory section is an editorial feature published in every issue for the convenience of the readers of MARITIME REPORTER. A quick-reference readers' guide, it includes the names and addresses of the world's leading manufacturers and suppliers of all types of marine machinery, equipment, supplies and services. A listing is provided, at no cost for one year in all issues, only to companies with continuing advertising programs in this publication, whether an advertisement appears in every issue or not. Because it is an editorial service, unpaid and not part of the advertisers contract, MR assumes no responsibility for errors. If you are interested in having your company listed in this Buyer's Directory Section, contact Mark O'Malley at momalley@marinelink.com

ALUMINUM BOATS

Brunswick Commercial and Government Products, 420 Megan Z Avenue, Edgewater, FL 70518, USA, tel:(386) 423-2914, BCGPINFO@WHALER.COM

ANCHORS & CHAINS

Anchor Marine & Supply, INC., 6545 Lindbergh, Houston, TX, tel:(800) 233-8014, fax:(713) 644-1185, sales@anchormarinehouston.com

DCL Mooring and Rigging, 4400 North Galvez Street, New Orleans, LA, USA, tel:504 941-4116, fax:504 947-8557, cody@dcl-usa.com contact: Cody Schnuriger, www.dcl-usa.com

ATTORNEYS

Blank Rome - Admiralty & Maritime Law, 600 New Hampshire Avenue, NW, Washington, DC, USA, tel:(202) 944-3568, fax:(202) 772-5858, PBroadbent@BlankRome.com

AUTOMATIC IDENTIFICATION SYSTEM

Saab TransponderTech AB, SE-589 41 Linköping, tel:46 13 180000, fax:46 13 182377, Info.transpondertech@saabgroup.com

BARGE FABRICATION

McDonough Marine Services, 1750 Clearview Pkwy, Suite 201, Metairie, LA 78634, USA, tel:800-227-4348, fax:(504) 780-8200, pstant@marmac.net

BATTERY CHARGERS

Ward's Marine Electric, 617 SW 3rd Avenue, Fort Lauderdale, FL 77258, USA, tel:(954) 523-2815, fax:(954) 523-1967, monica.avendano@wardsmarine.com

BOAT BUILDING AND DESIGN

Moose Boats, 274 Sears Point Road Port Sonoma Marina, Petaluma, CA, USA, tel:(707) 778-9828, fax:(707) 778-9827, abbie@mooseboats.com contact: Abbie Walther, www.mooseboats.com

Rigidized Metals Corporation, 658 Ohio Street, Buffalo, NY, USA

BOATBUILDING AND DESIGN

Brunswick Commercial and Government Products, 420 Megan Z Avenue, Edgewater, FL 70518, USA, tel:(386) 423-2914, BCGPINFO@WHALER.COM

Tampa Yacht Manufacturing, LLC, 4350 62nd Avenue North, Pinellas Park, FL, USA, tel:813-792-2114, fax:727-954-3436, robert.stevens@tampa-yacht.com contact: Robert Stevens, www.tampa-yacht.com

BOW AND STERN THRUSTERS

Omnithruster, 2201 Pinnacle Parkway Twinsburg, Ohio 44087, tel:330 963-6310, fax:330 963-6325, widmer@omnithruster.com

COATINGS/ CORROSION CONTROL/ PAINT

Hempel A/S, Lundtoftegårdsvej 91 2800 Kgs. Lyngby, tel:45 4593 3800, fax:45 4588 5518, marine@hempel.com, www.hempel.com

Tri-State Coating and Machine Co. Inc., 5610 McComas Road, PO Box 296, Salt Rock, WV V4W 3S8, USA, tel:1-800-477-4460, fax:304-736-7773, brichmond@tscminc.com contact: Beverly Richmond, www.tscminc.com

COMMUNICATIONS

David Clark Company (Wireless Headset Communication Systems), 360 Franklin Street, Worcester, MA 77060, USA, tel:(800) 298-6235, www.davidclarkcompany.com/marine

CORDAGE

Helkama Bica Oy, Lakimiehenkatu 4, KAARINA FI-20780, Finland, tel:+358-2-410 8700, sales@helkamabica.fi

CORROSION CONTROL

Rustibus, 2901 West Sam Houston Pkwy, North SUITE E-325, Houston, TX 77041, USA, tel:(832) 203-170, fax:(832) 203-7171, houston@rustibus.com

Ward's Marine Electric, 617 SW 3rd Avenue, Fort Lauderdale, FL 77258, USA, tel:(954) 523-2815, fax:(954) 523-1967, monica.avendano@wardsmarine.com

COUPLINGS

Centra Corporation, 2570 Beverly Drive #128, Aurora, IL 48331, USA, tel:(630) 236-3500, fax:(630) 236-3565, bobl@centacorp.com

CRANE - HOIST - DERRICK - WHIRLEYS

F&M MAFCO, Inc., 9149 Dry Fork Road, Harrison, OH, USA, tel:(800) 333-2151, fax:(513) 367-0363, websales@fmmafco.com contact: Jen Gardner, www.fmmafco.com

DECK MACHINERY- CARGO HANDLING EQUIPMENT

F&M MAFCO, Inc., 9149 Dry Fork Road, Harrison, OH, USA, tel:(800) 333-2151, fax:(513) 367-0363, websales@fmmafco.com

DRILLS

Hougen Inc., 3001 Hougen Drive Swartz Creek, MI 48473

DRIVESHAFTS

Centra Corporation, 2570 Beverly Drive #128, Aurora, IL 48331, USA, tel:(630) 236-3500, fax:(630) 236-3565, bobl@centacorp.com

EDUCATION

Sea School (U.S. Coast Guard Approved Courses), 8440 4th Street North, St. Petersburg, FL 70002, USA, tel:(800) 237-8663, cathybancroft@seaschool.com

ELECTRIC MOTORS AND CONTROLS

Ward's Marine Electric, 617 SW 3rd Avenue, Fort Lauderdale, FL 77258, USA, tel:(954) 523-2815, fax:(954) 523-1967, monica.avendano@wardsmarine.com

ELECTRICAL EQUIPMENT

Ward's Marine Electric, 617 SW 3rd Avenue, Fort Lauderdale, FL 77258, USA, tel:(954) 523-2815, fax:(954) 523-1967, monica.avendano@wardsmarine.com

ELECTRICAL SERVICES

Ward's Marine Electric, 617 SW 3rd Avenue, Fort Lauderdale, FL 77258, USA, tel:(954) 523-2815, fax:(954) 523-1967, monica.avendano@wardsmarine.com

ENVIRONMENTAL SOLUTIONS

Environmental Solution, Inc., P.O. Box 788, Wake Forest, NC 99835, USA, tel:(919) 740-0546, john@totalbiosolution.com contact: John Paparone, www.totalbiosolution.com

FANS

Ward's Marine Electric, 617 SW 3rd Avenue, Fort Lauderdale, FL 77258, USA, tel:(954) 523-2815, fax:(954) 523-1967, monica.avendano@wardsmarine.com

FASTNERS

Nord-Lock / Superbolt, Inc., 1000 Gregg St., Carnegie, PA 92138, USA, tel:(412) 279-1149, fax:(412) 279-1185, Jason.Milburn@nord-lock.com

FILTERS/FILTER SYSTEMS

UT 99 AG Oil Mist Separators, Schaubenstrasse 5 CH-8450 Andelfingen, Switzerland, tel:+41 52 397 11 99, fax:+41 52 397 11 90, info@ut99.ch, www.ut99.ch/en

FUEL ADDITIVES

Nano Fossil Fuels Technology, LLC, 550 South 16th Street, Sparks, NV 60504, USA, tel:775-356-0280, fax:775-356-0283, nanofuels@sbcglobal.net contact: Ernie Gislser, www.combustion-catalyst.com

GALLEY EQUIPMENT

LOIPART AB, P.O.Box 694/Metallgatan 2-4, ALINGSAS, tel:+46 322 668 360, fax:+46 322 637 747, loipart@loipart.se

GROUNDING & EARTHING BRUSHES

Sohre Turbomachinery, Inc., 128 Main Street, Monson, MA, USA, tel:413-267-0590, fax:413-267-0592, tsahre@sohreturbo.com contact: Tom Sohre, www.sohreturbo.com

INSURANCE SERVICES

WQIS (Water Quality Insurance Syndicate), 60 Broad Street 33rd Floor, New York, NY 18974, USA, tel:1-800-736-5750, fax:212-292-8716

INTERIORS

Rigidized Metals Corporation, 658 Ohio Street, Buffalo, NY, USA

LAUNDRY EQUIPMENT

LOIPART AB, P.O.Box 694/Metallgatan 2-4, ALINGSAS, tel:+46 322 668 360, fax:+46 322 637 747, loipart@loipart.se

LIFESAVING EQUIPMENT

CM HAMMAR AB, CM Hammar AB August Barks Gata 15 421 32 Västra, Frölunda, Sweden, tel:+46 31 70965 50, fax:+46 31 497023, info@cmhammar.com, www.cmhammar.com

HANSEN PROTECTION AS, P.O. Box 218, Tykkemyr 27 1597 Moss, Norway, tel:tel: +47 6900 1300, fax:fax: +47 6900 1301, hpro@hansenprotection.no, www.hansenprotection.no

LIGHTING SYSTEMS/ EQUIPMENT

Ward's Marine Electric, 617 SW 3rd Avenue, Fort Lauderdale, FL 77258, USA, tel:(954) 523-2815, fax:(954) 523-1967, monica.avendano@wardsmarine.com

MARINE TRANSPORTATION

Central Boat Rentals, Inc., P.O. Box 2545, Morgan City, LA, USA, tel:985-384-8200, fax:985-384-8455, earl@centralboat.com or gary@centralboat.com

MILITARY PATROL CRAFT MANUFACTURERS

Brunswick Commercial & Government Products, 420 Megan Z Avenue, Edgewater, FL 80204, USA, tel:(386) 423-2900, kelsey.nemeth@whaler.com, www.brunswickcgp.com

NAVAL ARCHITECTS, MARINE ENGINEERS

Aveva Solutions Ltd, High Cross, Madingley Rd, Cambridge CB3 0HB, UK, tel:Tel +44 1223 556655, www.aveva.com

JMS Naval Architects, 34 Water Street, Mystic, CT 22203, USA, tel:(860) 536-0009 EXT 16, fax:(860) 536-9117, RickF@JMSnet.com contact: Rick Fernandes, www.jmsnet.com

PIPE

FITTINGS/CUTTINGS/CONNECTING/ SYSTEMS

Tube-Mac Piping Technologies Ltd., 853 Arvin Avenue, Stoney Creek 32168, Canada, tel:(905) 643-8823, x119, fax:(905) 643-0643, chris.peitchinis@tube-mac.com

PROPULSION CONTROL SYSTEMS

Centra Corporation, 2570 Beverly Drive #128, Aurora, IL 48331, USA, tel:(630) 236-3500, fax:(630) 236-3565, bobl@centacorp.com

PROPULSION EQUIPMENT

VOLVO PENTA OF THE AMERICAS INC, 1300 Volvo Penta Drive, Chesapeake, VA, tel:+1 757 3824010, lindsay.shrewsbury@volvo.com contact: Customer Relations Support, www.volvopenta.com

PUMPS

Ward's Marine Electric, 617 SW 3rd Avenue, Fort Lauderdale, FL 77258, USA, tel:(954) 523-2815, fax:(954) 523-1967, monica.avendano@wardsmarine.com

RIBS & INFLATABLE BOATS

Wing Inflatables, 1220 5th Street, Arcata, CA, USA, tel:(707) 826-2887, ewing@wing.com, www.wing.com

ROTATING EQUIPMENT

Sohre Turbomachinery, Inc., 128 Main Street, Monson, MA, USA, tel:413-267-0590, fax:413-267-0592, tsahre@sohreturbo.com

RUST AND PAINT REMOVAL

Rustibus, 2901 West Sam Houston Pkwy, North SUITE E-325, Houston, TX 77041, USA, tel:(832) 203-170, fax:(832) 203-7171, houston@rustibus.com

SALT REMOVING PRODUCTS

Holdtight Solutions, PO Box 27907 Houston, TX 77227-7507, tel:713 266- 9339, sales@holdtight.com

SEA AND AIR FREIGHT

Amerijet International, Inc., 3401-A NW 72nd Ave., Miami, FL 07001-0030, USA, tel:844-859-2016, sales@amerijet.com, www.amerijet.com

SEALS

Seco Seals, Inc., 1370 Logan Ave. Unit K, Costa Mesa, CA 63110, USA, tel:(714) 546-3478, secoseals@aol.com

SHIP REPAIR

Advanced Mechanical Enterprises, 217 SW 28th Street, Fort Lauderdale, FL 98052, USA, tel:(866) 377-0770, fax:(954) 527 - 0338, Christine@amesolutions.com

SHIPPING CARGO

Amerijet International, Inc., 3401-A NW 72nd Ave., Miami, FL 07001-0030, USA, tel:844-859-2016, sales@amerijet.com

STEEL, PIPE, ALUMINUM & ALLOY SURPLUS - PURCHASING

Texas Iron & Metal, 865 Lockwood Drive, Houston, TX 36652, USA, tel:713-672-7595, fax:713-672-0653, maxr@texasironandmetal.com contact: Max Reichenthal, www.texasironandmetal.com

STEEL, PIPE, ALUMINUM & ALLOYS

Texas Iron & Metal, 865 Lockwood Drive, Houston, TX 36652, USA, tel:713-672-7595, fax:713-672-0653, maxr@texasironandmetal.com contact: Max Reichenthal, www.texasironandmetal.com

STEERING GEARS/ STEERING SYSTEMS

Jastram Engineering, 135 Riverside Drive, North Vancouver, BC, North Vancouver, Canada, tel:(604) 988-1111, fax:(604) 986-0334, dholve@jastram.com

SURFACE PREP TOOLS

Rustibus, 2901 West Sam Houston Pkwy, North SUITE E-325, Houston, TX 77041, USA, tel:(832) 203-170, fax:(832) 203-7171, houston@rustibus.com

TRAINING

Freelance Software, 39 Peckham Place Bristol, RI 02809, Bristol, RI, USA, tel:(401) 556-1955, fax:(401) 396-9717, chris@hawsepipeline.com contact: Christopher Dady, www.hawsepipeline.com

TRANSMISSIONS

Centra Corporation, 2570 Beverly Drive #128, Aurora, IL 48331, USA, tel:(630) 236-3500, fax:(630) 236-3565, bobl@centacorp.com

VACUUM TOILET SYSTEM

Jets Vacuum AS, Myravegen 1 6060 Hareid, tel:47 700 39 100, fax:47 700 39 101, post@jets.no

VIBRATION ANALYSIS

Advanced Mechanical Enterprises, 217 SW 28th Street, Fort Lauderdale, FL 98052, USA, tel:(866) 377-0770, fax:(954) 527 - 0338, Christine@amesolutions.com

WATER JET SYSTEMS

MJP Marine Jet Power AB, 1110A Claycraft Rd. Columbus, OH, USA, tel:(614) 759-9000, www.marinejetpower.com

WINCH MANUFACTURER

Patterson Company, 870 Riversea Road, Pittsburgh, PA 30004, USA, tel:(412) 322-2012, fax:(412) 322-2785, russ.mayhew@pattersonmfg.com

WIRES & CABLE

Ward's Marine Electric, 617 SW 3rd Avenue, Fort Lauderdale, FL 77258, USA, tel:(954) 523-2815, fax:(954) 523-1967, monica.avendano@wardsmarine.com



Download the all new Maritime GlobalNews App from *Maritime Reporter*. All the relevant industry news at your fingertips.

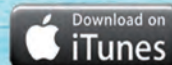



(206) 232-6041
www.maritimerecruiters.com
June@maritimerecruiters.com
 Established 1969

Get essential maritime business news - direct from industry leaders

www.maritimeprofessional.com



Van Aalst Marine & Offshore is a leading supplier for cargo systems for the offshore oil & gas industry. We are successful due to numerous innovations which have become industry standard. Since 2011 we are active with an own office in "the oil capital of the world", Houston. We are hiring an Area Sales Manager USA.

Job Title: Sales Manager USA
 Responsible for the USA market and our new office in Houston

Responsibilities
 You will be responsible for the technical and commercial preparation, as well as for actually preparing complete proposals and concluding contracts. You will be the link between the customers and the internal organization. You will report to the Commercial Director.

- What do we ask?**
- Good commercial and communication skills and a customer-orientated attitude.
 - Experience in preparing quotations and budgets.
 - Experience in sales in the maritime and/or offshore industry is seen as an advantage.
 - Technical and/or nautical education level or equivalent by experience.
 - Independent, decisive and result-orientated.
 - English language in word and writing.
 - You can work under pressure and you are accurate.
 - You have a practical attitude and you are willing to work within a company that is growing rapidly.
 - You are willing to work and live in Houston, TX.

What do we offer?
 Van Aalst Marine & Offshore offers you a challenging and responsible position within a dynamic and innovative organization, which is characterized as open and informal. Our organization is currently in a phase where entrepreneurship and co-operation are the key words. You will be working in an environment with engineers and clients that will stimulate you. Our company has excellent employee benefits.

Interested?
 Your application should be sent to:
 Van Aalst Marine & Offshore
 Attn. Mr. C. Zuur
 Baanhoekweg 16, 3313 LA Dordrecht, The Netherlands
 Or e-mail to: cees@vanaalstmarine.com

MASSACHUSETTS MARITIME ACADEMY

Founded in 1891, the Massachusetts Maritime Academy is the nation's oldest and finest co-ed maritime college. The Academy prepares young women and men for exciting and rewarding careers on land and sea. Our graduates have been at the very top of seagoing, engineering, environmental, and international business professions.

POSITIONS AVAILABLE

- Professional Maritime Faculty (2 positions available)
- Tenure-track Engineering Faculty (2 positions available)
- Tenure-track Marine Transportation Faculty (2 positions available)
- Engineering Lab Tech

The Academy is located in Buzzards Bay at the mouth of the scenic Cape Cod Canal and is a special mission college within the Massachusetts university college system.



For information about this positions and how to apply, visit the employment quick link on our web page at www.maritime.edu.

Massachusetts Maritime Academy is an AA/EEO employer. Under-represented groups are encouraged to apply.

PORT CAPTAIN WANTED

- Competitive wages
- Comprehensive medical and dental plan
- 401K with company match
- Employee bonuses
- Long term disability and life insurance

Apply online at www.parkertowing.com/application



1001 3rd Street
 Northport, AL 35476
 205.391.1100 Ext 138
www.parkertowing.com

MaritimeJobs.com

where employers and job seekers connect

The Maritime Industry's Leading Employment Website. For more information contact: Jean Vertucci at vertucci@marinelink.com

Bouchard Transportation Co., Inc.

Asst Engineer

Qualifications:

- Degree from Merchant Marine Academy or 3 year's experience working on tugs of at least 2,000 HP
- MMD DDE 1,000 to 4,000 HP
- STCW
- TWIC

Tankerman AB/Cargo Mate

Qualifications:

- Minimum of a AB Tankerman PIC (BARGE)
- STCW
- TWIC

Tug Mate

Qualifications:

- Minimum of a 200ton Mate Near Coastal with Radar Observer, TOAR, STCW and VSO endorsements
- TWIC
- GMDSS operator/maintainer a plus
- Recency in Northeast a plus

Apply online at

www.Bouchardtransport.com

Click on the employment link and submit through the Vessel Employment Opportunity link.



Magazines should be sent to people who want to read them.

Only advertise in magazines with a 100% Request Rate



"Why am I getting this magazine?? I've never subscribed to it!" Always check the audit report to verify your advertisement will be seen by the correct people, not just an old mailing list.



Since 1939

BPA Audited
100% Requested
100% 1 or 2 year circ

LICENSED PROFESSIONALS
WORLDWIDE VESSEL DELIVERY
Masters, Engineers and Crews
www.bayfrontmarineinc.com
bfm@bayfrontmarineinc.com
Contact Mel or Diane Longo 904-824-8970

BOLAND
INDUSTRIAL

The Leader in Vibration Analysis
Call Us Today at 251-232-7163
www.bolandindustrial.com

Established in 1854

CRANDALL
DRY DOCK ENGINEERS, INC.

- Consulting • Design • Inspection
- Railway and Floating Dry Docks
- Dry Dock Hardware and Equipment

Box 505804, Chelsea, MA 02150 (617) 884-8420 Fax: (617) 884-8466
www.crandalldrydock.com

NAVAL ARCHITECTURE
CONCEPTUAL DESIGNS
MARINE ENGINEERING
PRODUCTION ENGINEERING
LOFTING & NESTING
TOOLING DESIGN

BOKSA
Marine Design

BoksaMarineDesign.com 813.654.9800

C. R. CUSHING & Co., INC.
NAVAL ARCHITECTS • MARINE ENGINEERS • TRANSPORTATION CONSULTANTS

30 VESEY ST
7TH FLOOR
NEW YORK, NY
10007

SINCE
1968

Ph: (212) 964-1180
Fax: (212) 285-1334
info@crcco.com
www.crcco.com

DOWNEY
engineering corporation

- Naval Architecture
- Structural Engineering
- Project Management

One Galleria Boulevard, Suite 907
Metairie, Louisiana 70001
Phone: 504.818.0377 Fax: 504.818.0447
www.downeyengineering.com

A Few GHS Features at Random ...
 Rig wizard for finding critical axis and maximum VCG.
 * Customizable graphics showing loads and flooding.
 * Wind heeling moments in any direction derived from model.
 * Powerful macro language for automating launching, etc.
 * Good for onboard, salvage, probabilistic damage, etc. etc.
 ... just a reminder that GHS is truly general purpose.
www.ghsport.com/home/index.htm



Ship Stability and Strength Software

GHS Full-featured naval architect's system
 GHS Load Monitor (GLM) Onboard configuration
 BHS Basic hydrostatics and stability

Creative Systems, Inc.
 Creators of GHS™

P.O. Box 1910 Port Townsend, WA 98368 USA
 phone: (360) 385-6212 email: sales@ghsport.com
www.GHSport.com
 For 42 years, the software that naval architects love.

SPECIALISTS IN THE DESIGN OF:
 • OFFSHORE SUPPORT VESSELS
 • TUGS AND TOWBOATS
 • BARGES
 • HIGH SPEED CRAFT
 • NAVAL VESSELS
 • CREWBOATS
 • SPECIAL PURPOSE VESSELS
 • YACHTS



DESIGN, CONSULTING, SURVEYING AND DRAFTING SERVICES

GUARINO & COX, LLC
 Naval Architects, Marine Designers and Consultants
 19399 Helenburg Road Suite 203 Covington, LA 70433
 Tel: (985) 871-9997 Fax: (985) 871-9927 www.guarino-cox.com



NAVAL ARCHITECTURE
 MARINE ENGINEERING
 MARITIME SOLUTIONS

TECHNOLOGY ASSOCIATES, INC.

www.TAIEngineers.com



NEW ORLEANS, LOUISIANA

HEGER DRY DOCK, INC.

531 Concord Street, Holliston, MA 01746
 Engineering for all types of dry docks

- Design
- Docking Calculations
- Certifications
- Engineer/Diver
- Inspections
- U.S. Navy 1625D FCR's

Phone: (508) 429-1800 Fax: (508) 429-1811
www.hegerdrydock.com

M.A.C.E.

Marine Industry

FT. LAUDERDALE - USA - WORLDWIDE
 PHONE: (954) 563-7071 FAX: (954) 568-6598

- N.D.T Services
- Vibration - noise - structural/modal analysis
- Field balancing, Laser Alignment
- Torque - torsional vibration analysis
- IR - Thermography inspection
- Emmision tests, Engine Performance tests
- Low Location Light Testing

GEORGE G. SHARP, INC.



22 CORTLANDT STREET, NEW YORK, NY 10007
 TEL (212) 732-2800 FAX (212) 732-2809

WASHINGTON (703) 835-9997
 VIRGINIA BEACH (757) 499-4125
 SAN DIEGO (619) 425-4211

www.ggsharp.com
 MARINE SYSTEMS • ANALYSIS & DESIGN



Herbert Engineering Corp.

Naval Architecture Marine Engineering Ocean Engineering
 Marine Transportation Consulting Marine Software Development

Optimizing safety, efficiency,
 and environmental performance through design

510-814-9700 • www.herbert.com

MSCorp

MarineSystemsCorporation

70 Fargo Street
 Boston, Ma 02210
 p: 617-542-3345
 f: 617-542-2461
www.msccorp.net

Excellence in Engineering and Design
 Government and Commercial Support
 Since 1973

Marine Engineering
 Naval Architecture
 Logistic Support
 Maintenance Planning

Fast underwater repair and maintenance services



Hydrex LLC - Tampa, U.S.A.
 Phone: +1 727 443 3900 (24/7)
 E-mail: info@hydrex.us

www.hydrex.us

CG State Pilotate License Insurance/ Mariners' Disability Insurance
 For Quotes on License Insurance or Mariners' Disability Insurance
 See our web site: marinelicenseinsurance.com

R.J. MELLUSI & CO.
 29 Broadway, Suite 2311
 New York, N.Y 10006
 Ph: (212) 962-1590
 Fx: (212) 385-0920
Rjmellusi@sealawyers.com



GILBERT ASSOCIATES, INC.

Naval Architects
 and Marine Engineers



350 Lincoln St., Suite 2501
 Hingham, MA 02043
 T: (781) 740-8193 • F: (781) 740-8197
 E-mail: inbox@jwgainc.com
www.jwgainc.com



LAY, PITMAN & ASSOCIATES, INC.
 NAVAL ARCHITECTS

- Naval Architecture Services
- Marine Engineering
- Design Services
- Construction Administration
- Regulatory Liaison
- Inspections and Surveys

13891 Atlantic Blvd., Jacksonville, FL 32225
 (904) 221-7447 • www.laypitman.com

"Maritime Reporter is our least expensive sales person"
 "DMW has been advertising in various print media for many years. In the past 18 months on two separate occasions we were contacted by individuals who saw our full page AD in your publication. Both customers purchased cranes from us. We did not count on these results from print ads but have since committed to at least 5 full page Ads a year with *Maritime Reporter*."
 - Doug Weidner - DMW Marine Group



ABS Approved Ambient
 Environmental Testing
 Climate, Lighting,
 Noise & Vibration

1 Galleria Blvd. Ste 907 Metairie, LA 70001
 Phone (504) 818-0377 x 33 Fax (504) 818-0447
www.hab-cert.com

Deckplate experience
 behind every design.

Introducing our latest delivery in the
 JMS Coastal Research Vessel Design Series:
ARCTICUS



JMS
 NAVAL ARCHITECTS

Naval Architecture
 Marine Engineering
 Shipyard Engineering Support
 Marine Surveys

860.536.0009
www.JMSnet.com



**ENGINEERS IN VIBRATION
NOISE AND SHOCK CONTROL**

www.christiegrey.com
Toll Free (888) 472-8290



BLUE OCEAN TACKLE INC
Marine Fenders - Oil Spill Products

MARINE FENDER & DOCK SYSTEMS
RUBBER FENDERS ~ PANEL FENDERS
ANCHORS ~ CHAIN ~ PELICAN HOOKS
ABSORBENTS ~ DREDGE PIPE FLOATS
UNDERWATER LIFT & SALVAGE BAGS

D-SHAPE, WING & TUGBOAT FENDERS
LIFE RAFTS ~ WINCHES ~ SHACKLES
SHIP LAUNCHING MARINE AIRBAGS
BUOY RELEASE HOOKS ~ CRANES
MOORING LINES ~ ROPE ~ BUOYS

BLUE OCEAN TACKLE INC
1545 Tidelands Ave, Unit E • National City, CA 91950
Tel: (619) 336-2403 • Fax: (619) 649-0909
sales@blueoceantackle.com
www.blueoceantackle.com

"AUTHORIZED NABRICO DISTRIBUTOR"

5000' PERMITTED BARGE FLEET
West Bank of Michoud Canal at New Orleans
off Gulf Intracoastal Waterway east of Inner
Harbor Locks, inside surge protection barrier.
Contact Paul Ramoni
504-813-7787 • peramoni@gmail.com

**USCG
License Software**

Affordable - Merchant Marine Exam Training
<http://hawsepipe.net>

Freelance Software
39 Peckham Place
Bristol, RI 02809
(401) 556-1955 - sales@hawsepipe.net

U.S.C.G
Licensed **CAPTAINS**



Have you thought about the accomplishment you have made by obtaining a Captain's License? The many hours of study and time at sea?

Here is Your Reward!

Fine Handcrafted Jewelry for 20 Years **1-800-584-0242**
www.captainsring.com

Muldoon Marine Services
COMMERCIAL DIVING • MARINE SERVICES

REDUCE FUEL CONSUMPTION
Propeller Polishing, Hull Cleaning

UWILD SURVEYS
Approved By All Major Class Societies

IN-WATER REPAIRS



24-Hour: (562) 432 5670
Long Beach, CA
www.muldoonmarine.com



**WE SELL THE FINEST
MARINE CRANES, OIL BOOMS
& MARINE PUMPS MADE**

Davit Sales Inc. Tel: 914-962-4544 • Fx: 914-962-5418
info@davitsalesinc.com



WWW.DAVITSALESINC.COM



WHEN PERFORMANCE COUNTS

You can rely on Stone Marine for designing and manufacturing your high-end propeller and sterngear solutions. Using the latest design and engineering technology you can be assured of outstanding performance and delivery.

STONE MARINE SINGAPORE PTE LTD.
4 Tuas Basin Close, Singapore, 638797 | T +65 6863 2681 | E sales@stonemarine.com

Be Organized - Be Compliant - Be Safe

Ocean Charting Services

- Self-adhesive chartlets
- Correct your paper charts
- No hand drawn corrections

www.oceanchartingservices.com
410-820-9600

FREE TRIAL - 2 Vessels, 2 Months
TIME SAVED PAYS FOR SERVICE

**Industrial Grade
Pressure Washers**



WATER CANNON .COM
1.800.333.9274



**Custom Sea Water Intake Filters
Strainers and Screens**

Call us for your free estimate
866-265-0502

Yankee Wire Cloth Products, Inc.
Since 1963

221 W. Main St.,
West Lafayette OH 43845
Fax: 740-545-6323

www.maritimefilter.com



Subsalve USA

America's largest manufacturer of Underwater Lift Bags available from 25 lbs. to 50 tons and Water Load Test Bags to 50 tons. Large inventory available. IMCA compliant. ABS Approved.



P.O. Box 2030, North Kingstown, RI 02852, USA
Tel: +1 401 884 8801 Fax: +1 401 884 8868
www.subsalve.com richard@subsalve.com

WE BUY STEEL!
EXCESS · OVERSTOCK
SPEC CHANGES · CANCELLED JOB

**PLATE · STRUCTURAL STEEL
BULB FLATS · PIPE**

866.574.0560
texasiron-steel.com



TEXAS IRON & METAL
SUPPLY ON DEMAND.
Houston, Texas | buyer@texasironandmetal.com

Vesconite Hilube
Rudder and Stern Tube Bearings

- Use dry or underwater
- No grease needed
- Lowest friction
- Fit and forget



Call for free Design Manual
1-866-635-7596
www.vesconite.com



Maritime Global News
for iPhone and Android



FREE APP SCAN THE CODE TO DOWNLOAD



Maritime Reporter Reaches the Right Audience!

"Water Cannon has really benefitted from our consistent advertising in your publications, so much that we have decided to triple our budget for 2015 and run in all three of your publications. *Marine News*, *Maritime Reporter* and *Maritime Professional*. The quality of your subscribers have made Water Cannon a leader in the Maritime Industry for Industrial Pressure Washing Equipment."
- Richard Kurtz, CEO - Director, Water Cannon, Inc.

CENTRAL BOAT RENTALS, INC.
Morgan City, LA

Ocean Barges: 180x54x12 260x72x16
Tank Barges: 10K & 30K bbl Double Skin
Ocean Towing Barge Fleeting
Shipyard Services

(985) 384-8200 centralboat.com

MARITIME PROPULSION
Powering the Maritime Industry

Over 600,000 pages indexed by Google

- engine specs
- product listings
- suppliers
- auxiliary machinery

www.maritimepropulsion.com



We buy barges, ships, and other marine vessels and structures for scrap.
We adhere to the highest ES&H standards.
Serving the rivers and coasts of the U.S.

AMELIA • BROWNSVILLE
LAKE CHARLES • MOBILE
MORGAN CITY • NEW ORLEANS
us.emrgroup.com
CALL 800 - GO SCRAP

FOR SALE
Office Barge 290 x 52
Hull Dry Docked and Painted 2012
Main Deck Capped With 6" Concrete
40 x 60 Two Story 4800 SQ. FT. Office NEW 2012
Electrical 440 V 3PH. 150 KVA Transformer
Wired For Ethernet and Digital Phone Communications



Contact MIKE HOWARD 618-255-5713



ZIDELL MARINE CORPORATION

Specializing In Barges

- ◆ Single or Double Hull, Inland or Ocean-Going
- ◆ Design, Construction & Modification
- ◆ Chartering & Sales

Ask for Bill Gobel
503-228-8691 1-800-547-9259
3121 SW Moody Avenue, Portland, Oregon 97239

ADVERTISER INDEX

GET FREE INFORMATION ONLINE at: www.maritimeequipment.com/mr

Page#	Advertiser	Website	Phone #	Page#	Advertiser	Website	Phone #
57	ABS	www.eagle.org	(281) 877-5861	67	Hougen Inc.	www.hougen.com	(800) 426-7818
45	AER Supply	www.aersupply.com	(800) 767-7606	C4	Karl Senner, Inc.	www.karlsenner.com	(504) 469-4000
37	Air Products AS	www.airproducts.no	Please visit our website	15,37	Kidde-Fenwal, Inc	www.kiddemarine.com	(508) 881-2001
37	Alfa Laval Tumba AB	www.alfalaval.com/marine	Please visit us online	3	KVH	www.kvh.com/powerofone	(401) 847-3327
19	American Chemical Technologies, Inc.	www.NeptuteEals.com	(800) 938-0101	13	Louisiana Cat	www.louisianacat.com	(866) 843-7440
37	American Vulkan	www.vulkan.com	(863) 324-2424	51	Malin International	www.malinshiprepair.com	(409) 682-0232
67	Anchor Maine & Supply, Inc	www.anchormarinehouston.com	(713) 644-1183	37	Man Diesel & Turbo	www.mandieselturbo.com	Please visit our website
27	Austal USA	www.austaljobs.com	Please visit our website	37	Marine Learning Systems	www.MarineLS.com	(855) E-MARINE (362-7463)
25	AVEVA SOLUTION	www.aveva.com/IEandDMarine.com	Please visit us online	67	Maritime Associates	www.marinesigns.com	775-832-2422
12	Baker Marine Solutions	www.bakermarinesolutions.com	(985) 845-9439	C3	McAllister Towing	www.McAllisterTowing.com	(212) 269-3200
57	Bug-O Systems International	www.bugo.com	(800) 245-3186	15	Motor Services Hugo Stamp, Inc.	www.mshs.com	(954) 763-3660
22	C & C Technologies, Inc.	www.cnav.com	(337) 210-0000	61	NABRICO Marine Products	www.nabrico-marine.com	(615) 442-1300
37	C.M. Hammar AB	www.cmhammar.com	Please visit us online	55	Nord-Lock, Inc. / Superbolt, Inc.	www.superbolt.com	Please visit our website
18	Chesapeake Shipbuilding, Corp.	www.chesapeakeshipbuilding.com	(800) 784-2979	37	R.W. Fernstrum	www.fernstrum.com	(906) 863-5553
C2	Citgo Petroleum-Clarion	www.clarionenvirosafety.com	1-855-MY-CLARION	67	Rustibus, Inc. / Safe Edge	www.rustibus.com	(832) 203-7170
17	Click Bond Inc	www.clickbond.com	(775) 885-8000	9	Scania USA	www.scaniausa.com	(908) 964-0700
59	Coastal Marine Equipment, Inc.	www.cmei.biz	(228) 832-7655	49	SEL Schweitzer Engineering Laboratories	www.selinc.com/12mr	(509) 339-2700
11	Daewoo Shipbuilding and Marine Engineering Co.,LTD	www.dsme.co.kr	Please visit us online	53	Senesco Marine	www.senescomarine.com	(401) 226-1042
37	Damen Shipyards Group	www.damen.com	31 183 63 9279	47	Sernamaz/Servicios Navales Mazatlan	www.senav.com.mx	52 (669) 180 2000
59	DCL Mooring and Rigging	www.dcl-usa.com	(800) 228-7660	69	Sohre Turbomachinery, Inc.	www.sohreturbo.com	(413) 267-0590
5	DMW Marine Group	www.dmwmarinegroup.com	(610) 827-2032	65	Superior Lidgerwood Mundy Corporation	www.lidgerwood.com	(715) 394-4444
23	Engines Inc	www.enginespower.com	(870) 268-3799	37	Transas Technologies Ltd	www.transas.com	46 31 769 5600
61	Environmental Solution, Inc.	www.totalbiosolution.com	(919) 740-0546	51	TTS MARINE INC.	www.ttsgroup.com	(281) 227-5999
7	ExxonMobil	www.exxonmobil.com/marine	Please visit our website	37	Vard AS	www.vard.com	Please visit us online
20	Floscan	www.floscan.com	(206) 524-6625	1	VT Halter Marine	www.vthaltermarine.com	(228) 696-6888
21	GE Transportation	www.getransportation.com	(814) 875-5710	41	Westfalia Separator, Inc.	www.wsus.com	(800) 722-6622
43	Great American Insurance	www.gaic.com	(212) 510-0135	61	Windrock	www.windrock.com	(865) 330-1100
37	Hempel	www.hempaguard.hempel.com	46 45 88 3800/45273676	72-73	World Energy Reports	www.worldenergyreports.com	(212) 477-6700

The listings above are an editorial service provided for the convenience of our readers. If you are an advertiser and would like to update or modify any of the above information, please contact: productionmanager@marinelink.com

a stack of
good wishes
for you...



McAllister

IT ALL STACKS UP TO A MERRY CHRISTMAS
and a Happy New Year



McAllister

BROTHERS, INC.

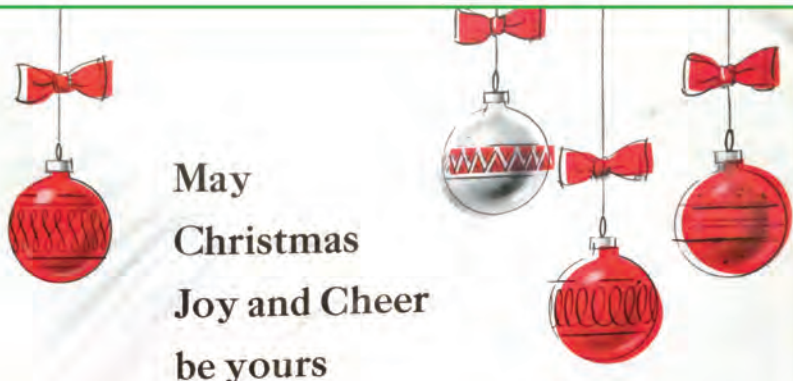

May
Christmas
Joy and Cheer
be yours



throughout
the
coming year

In 1864, James McAllister arrived in New York Harbor and launched the family business with 2 sail lighters. Today, as the fifth generation of the McAllister family continues the tradition of providing unsurpassed service to the maritime community, McAllister Towing has grown to a fleet of over 75 tugboats in 12 ports covering the US East Coast.

In honor of our 150th, as well as Maritime Reporter's 75th, anniversary we are reprising some of our historic advertisements. We found these holiday ads in the archives and thought it would be a great way to end this milestone year.

Happy Holidays to All!

www.mcallistertowing.com





PROPELLING EXCELLENCE

**KARL SENNER, LLC AND
ELECTRONIC POWER DESIGN
ARE PROUD TO
ANNOUNCE A STRATEGIC
REPRESENTATION AGREEMENT!**

**KARL SENNER, LLC
NOW OFFERS COMPLETE
INTEGRATED HYBRID AND DIESEL-ELECTRIC
PROPULSION SYSTEMS FOR MARINE
AND OFFSHORE MARKETS
IN NORTH AMERICA.**



**WEST COAST
Karl Senner, LLC
Seattle, WA
(425) 338-3344**

**GULF COAST
Karl Senner, LLC
25 W. Third St., Kenner, LA
(504) 469-4000**

**PADUCAH SERVICE FACILITY
Karl Senner, LLC
2401 Powell Street
Paducah, KY**

WWW.KARLSENNER.COM

WWW.EPDLTD.COM